



**Raymarine®**

## RCU-1

### Operation Instructions



## Legal notices

### Trademark and patents notice

**Raymarine®**, **Tacktick®**, **Pathfinder®**, **Clear Pulse®**, **Truzoom®**, **SeaTalk®**, **SeaTalk HS™**, **SeaTalk NG™**, and **MicroNet™**, are registered or claimed trademarks of Raymarine UK Ltd.

**FLIR®**, **Fishidy®**, **Fishing Hot Spots®**, **YachtSense™**, **DockSense®**, **RangeFusion™**, **DownVision®**, **SideVision®**, **RealVision®**, **HyperVision™**, **Wi-Fish®**, **Dragonfly®**, **Element®**, **Quantum®**, **Cyclone™**, **Alpha™**, **Axiom®**, **Infrared Everywhere**, **The World's Sixth Sense** and **ClearCruise®** are registered or claimed trademarks of Teledyne FLIR LLC.

**All other trademarks, trade names, or company names referenced herein are used for identification only and are the property of their respective owners.**

This product is protected by patents, design patents, patents pending, or design patents pending.

### Fair Use Statement

You may print no more than three copies of this manual for your own use. You may not make any further copies or distribute or use the manual in any other way including without limitation exploiting the manual commercially or giving or selling copies to third parties.

### Content notice

Please ensure that you have obtained this document only from Raymarine, and that it is the **latest** available version.

There are numerous third-party Internet websites (such as [www.manualslib.com](http://www.manualslib.com)) hosting Raymarine product manuals. These websites are not authorized by Raymarine to do so, and are often hosting illegitimate or older versions of Raymarine product manuals, which may contain inaccurate or misleading information.

To obtain the latest official documentation for a Raymarine product, please visit the official Raymarine website: [www.docs.raymarine.com](http://www.docs.raymarine.com)

### Artificial Intelligence (AI) content notice

There are numerous third-party **Artificial Intelligence (AI)** services available to the public, which are capable of providing a summary or transcription of the information provided by official Raymarine publications or websites, either in written or audio/video formats. These services may alter, supplement, or convey the original information provided by Raymarine in inaccurate or misleading ways.

Please ensure that you have obtained this document only from Raymarine, and that it is the **latest** available version.



# CONTENTS

<b>CHAPTER 1 IMPORTANT INFORMATION</b> .....	<b>8</b>	<b>CHAPTER 4 SOFTWARE DETAILS</b> .....	<b>18</b>
Safety warnings.....	8	4.1 Applicable software version.....	19
Product warnings.....	9	4.2 Compatible autopilot systems.....	19
Battery operation.....	9	4.3 Chartplotter compatibility.....	19
Regulatory notices.....	9	4.4 Software updates.....	19
Disclaimer.....	9	Updating multiple remotes.....	20
Declaration of Conformity.....	10	Wireless gateway software update.....	20
Water ingress.....	10	Updating software.....	20
Warranty policy and registration.....	10	<b>CHAPTER 5 GETTING STARTED</b> .....	<b>21</b>
Battery disposal.....	10	5.1 Inserting batteries.....	22
Product disposal.....	10	5.2 Connecting the lanyard.....	22
IMO and SOLAS.....	11	5.3 Using the cradle.....	22
Technical accuracy.....	11	5.4 Controls.....	23
Publication copyright.....	11	5.5 Powering on the remote.....	24
<b>CHAPTER 2 DOCUMENT INFORMATION</b> .....	<b>12</b>	5.6 Powering off the remote.....	24
2.1 Applicable products.....	13	5.7 Initial setup.....	24
2.2 Document information.....	13	User interface languages.....	24
2.3 Product documentation.....	13	Manual Bluetooth pairing.....	24
Obtain the latest documentation.....	13	5.8 Screen overview.....	25
2.4 Document conventions.....	13	5.9 Adjusting the display brightness.....	25
2.5 Document illustrations.....	14	5.10 Brightness page.....	26
<b>CHAPTER 3 PRODUCT AND SYSTEM</b>		5.11 Keylock.....	26
<b>OVERVIEW</b> .....	<b>15</b>	5.12 Switching to night mode.....	26
3.1 Product overview.....	16	5.13 Calibrating the internal sensors.....	27
3.2 Compatible gateway.....	16	5.14 Setting data responsiveness.....	27
3.3 Compatible autopilot systems.....	16	5.15 Setting the remote performance.....	27
3.4 Compatible autopilot controllers.....	17	<b>CHAPTER 6 AUTOPILOT MODES</b> .....	<b>28</b>
3.5 System example.....	17	6.1 Supported autopilot modes.....	29

6.2 Unsupported autopilot modes .....	29	7.2 Creating a data page .....	41
6.3 Disengaging the autopilot — STBY .....	29	7.3 Customizing a data page.....	41
6.4 Engaging the autopilot — Steer to Heading (AUTO).....	29	7.4 Deleting data pages.....	42
6.5 Engaging the autopilot — Steer to Navigation.....	30	7.5 Data items.....	42
6.6 Engaging the autopilot — Steer to Wind .....	30	<b>CHAPTER 8 ALARMS .....</b>	<b>44</b>
6.7 Engaging the autopilot — Power steer .....	31	8.1 Alarms .....	45
6.8 Steer to Heading .....	31	Instrument alarms.....	45
Adjusting locked heading .....	31	Local alarms.....	45
6.9 Steer to Navigation .....	32	Configuring an alarm example .....	45
Navigation page .....	32	8.2 Alarm settings .....	46
Overriding navigation .....	32	8.3 Setting the countdown timer .....	46
Cross Track Error (XTE).....	33	<b>CHAPTER 9 POINT AND GO AND WAYPOINTS.....</b>	<b>48</b>
Waypoint arrival and route complete .....	33	9.1 Waypoints .....	49
Automatic turning.....	34	9.2 Point and Go .....	49
Advance waypoint .....	34	9.3 Performing a Point and Go .....	49
6.10 Steer to wind modes .....	35	<b>CHAPTER 10 SOLO SAILOR AND MAN OVERBOARD .....</b>	<b>50</b>
Mirrored TWA and Fixed angles.....	35	10.1 Solo sailor .....	51
Target wind angle from polar .....	35	10.2 Man overboard .....	51
Polar performance .....	36	Cancelling a MOB alarm .....	51
Operating hints for wind vane mode.....	36	10.3 Lost connection MOB.....	52
Steer to Wind .....	37	Cancelling the Lost connection MOB alarm .....	52
Adjusting the wind angle .....	37	<b>CHAPTER 11 SETTINGS.....</b>	<b>53</b>
Tacking .....	37	11.1 Main menu.....	54
Gybing.....	38	11.2 Pilot settings menu.....	55
6.11 Power steer .....	39	11.3 Settings menu.....	55
Steering the vessel .....	39	Shortcut button options .....	56
<b>CHAPTER 7 DATA PAGES .....</b>	<b>40</b>		
7.1 Data pages .....	41		

CHAPTER 12 TROUBLESHOOTING .....	57
12.1 Troubleshooting .....	58
12.2 Connection troubleshooting .....	58
12.3 WG-1 LED diagnostics .....	59
LED diagnostic guidance.....	60
CHAPTER 13 MAINTENANCE.....	61
13.1 Routine equipment checks.....	62
13.2 Replacing the batteries.....	62
13.3 Product cleaning .....	62
Cleaning the display case.....	62
Cleaning the display screen.....	62
CHAPTER 14 TECHNICAL SUPPORT .....	63
14.1 Raymarine technical support and servicing .....	64
14.2 Viewing product information.....	65
14.3 Viewing product information from a chartplotter.....	65
14.4 Learning resources .....	66
APPENDIX A NMEA 2000 PGN SUPPORT .....	67

# CHAPTER 1: IMPORTANT INFORMATION

## Safety warnings



### Warning: Aid to navigation

This product is intended only as an aid to navigation and must never be used in preference to sound navigational judgment. It is the user's responsibility to use official government charts, notices to mariners, caution and proper navigational skill when operating this or any other Raymarine product.



### Warning: Maintain a permanent watch

Always maintain a permanent watch, this will allow you to respond to situations as they develop. Failure to maintain a permanent watch puts yourself, your vessel and others at serious risk of harm.



### Warning: Autopilot usage

Autopilots navigate a preset course and do NOT respond to hazards automatically. The operator must remain at the helm at all times and be ready to avoid hazards and warn passengers of course changes.



### Warning: Day mode brightness warning

Switching from Night mode to Day mode instantly increases the display brightness to maximum. This will impact the operator's night vision, due to the relative brightness of Day mode in night time conditions.



### Warning: Battery safety

Before handling, charging, installing or using your battery please ensure you have read and understood the safety related information provided below.

- Do NOT expose the battery to sources of excessive heat, flame or sparks.
  - Do NOT drop, throw, crush or attempt to disassemble the battery
  - Do NOT use the battery if it is damaged.
  - Do NOT submerge the battery.
  - Do NOT short the battery terminals.
  - Do NOT operate the battery outside of its operating temperature range. Refer to the product's technical specification for more information.
  - Ensure battery disposal is in accordance with applicable local laws and regulations.
  - Do NOT use solvents or solvent based cleaning agents to clean your battery.
  - Keep batteries away from children.
  - Contact with battery acid may cause irritation or chemicals burns, irritation may occur to the eyes, skin or respiratory system. If contact is made flush with clean water immediately.
- Failure to adhere to the guidelines above may result in shortened battery life, risk of damaging the device, fire, chemical burns, acid leakage or injury to persons.



### Warning: Battery care

Before handling, charging, installing or using your battery please ensure you have read and understood the safety related information provided below.

- Ensure that the battery is charged before storing.
- Ensure that the battery is disconnected before it is stored for a prolonged period without recharge.
- Always store the battery in a cool and dry area that is well-ventilated and not in direct sunlight.
- Do NOT leave the battery in high temperature areas such as in a vehicle on a sunny day.
- Do NOT store the battery outside of its storage temperature range. Refer to the product's technical specification for more information.

Failure to adhere to the guidelines above may result in shortened battery life, irreparable damage to your battery, risk of damaging the device, fire, chemical burns, acid leakage or injury to persons.

### Caution: Float recommendation

It is recommended that you attach a float to the remote's lanyard so that it can be retrieved if dropped overboard.

### Caution: Service and maintenance

This product contains no user serviceable components. Please refer all maintenance and repair to authorized Raymarine dealers. Unauthorized repair may affect your warranty.

## Product warnings

### Battery operation

Battery care and operation guidance.

- When used in colder temperatures, the batteries will discharge more quickly than in warmer conditions.
- When using a high display brightness, the batteries will discharge more quickly.
- Stored batteries will slowly discharge over time.
- The batteries are recyclable, and you must follow local laws and regulations for safe battery disposal.
- The batteries are sealed, maintenance-free units.

## Regulatory notices

### Disclaimer

Raymarine does not warrant that this product is error-free or that it is compatible with products manufactured by any person or entity other than Raymarine.

Raymarine is not responsible for damages or injuries caused by your use or inability to use the product, by the interaction of the product with products manufactured by others, or by errors in information utilized by the product supplied by third parties.

Third-party hardware, such as converters, adapters, routers, switches, Access Points etc., provided by third parties, may be made available directly to you by other companies or individuals under separate terms and conditions, including separate fees and charges. Raymarine UK Ltd or its affiliates have not tested or screened the third-party hardware.

Raymarine has no control over, and is not responsible for:

- (a) the content and operation of such third-party hardware; or
- (b) the privacy or other practices of such third-party hardware.

The fact that Raymarine's documentation may make reference to such third-party hardware does not indicate any approval or endorsement of any such third-party hardware. Raymarine may reference such third-party hardware only as a convenience.

**THIS INFORMATION IS MADE AVAILABLE BY Raymarine ON THE BASIS THAT YOU EXCLUDE TO THE FULLEST EXTENT LAWFULLY PERMITTED ALL LIABILITY WHATSOEVER FOR ANY LOSS OR DAMAGE HOWSOEVER ARISING OUT OF THE USE OF THIS INFORMATION OR RELIANCE UPON THIS INFORMATION.**



**Raymarine** does not exclude **Raymarine's** liability (if any) to you for personal injury or death resulting from **Raymarine UK Ltd** negligence, for fraud or for any matter which it would be illegal to exclude or to attempt to exclude.

## Declaration of Conformity

Declaration of Conformity for product sold into European Union (EU) member state regions, and the United Kingdom (UK).

Raymarine UK Ltd declares that the radio equipment type products listed below are in conformity with the relevant sections of the listed designated standards and / or other normative documents:

- RCU-1 Autopilot Remote Control, part number: A80835.
- RCU-1 Autopilot Remote Control with WG-1 Wireless Gateway, part number: E70718.

Region	Standard	Mark
UK	EMC Regulations 2016	
EU	Radio Equipment Directive 2014/53/EU	

The original Declaration of Conformity certificates may be obtained via the documentation page at [www.bit.ly/RCU-1-docs](http://www.bit.ly/RCU-1-docs)

## Water ingress

Water ingress disclaimer

Although the waterproof rating capacity of this product meets the stated water ingress protection standard (refer to the product's *Technical Specification*), water intrusion and subsequent equipment failure may occur if the product is not installed correctly or subjected to high-pressure washing. Raymarine will not warrant products subjected to high-pressure washing.

## Warranty policy and registration

Visit the Raymarine website to **read the latest warranty policy**, and **register** your product's warranty online: [www.bit.ly/rym-warranty](http://www.bit.ly/rym-warranty)

It is important that you register your product to receive full warranty benefits. Your product package includes a barcode label indicating the serial number of the unit. This serial number is also provided on a label affixed to the product itself. You will need this serial number when registering your product online.

## Battery disposal

Consumers in European Union (EU) Member State regions are required to dispose of the battery (or batteries) included with this product in accordance with the EU Battery Directive (2006/66/EC).

The Battery Directive requires the proper waste management of batteries, including their recycling, collection, take-back programs, and disposal. The purpose of the Directive is to ensure the appropriate management of waste batteries which contain materials and chemicals that may be hazardous and present a risk to human health and / or the environment, when not handled correctly.

Local authorities in many regions have established collection schemes under which residents can dispose of waste batteries at a recycling center or other collection point. For a list of relevant websites for each region, visit: [www.bit.ly/rym-recycling](http://www.bit.ly/rym-recycling)

## Product disposal

Dispose of this product in accordance with the WEEE Directive.

The Waste Electrical and Electronic Equipment (WEEE) Directive requires the recycling of waste electrical and electronic equipment which contains materials, components and substances that may be hazardous and present a risk to human health and the environment when WEEE is not handled correctly.

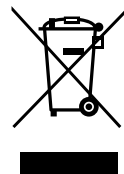

Equipment marked with the crossed-out wheeled bin symbol indicates that the equipment should not be disposed of in unsorted household waste. Local authorities in many regions have established collection schemes under which residents can dispose of waste electrical and electronic equipment at a recycling center or other collection point. For more information about suitable collection points for waste electrical and electronic equipment in your region, refer to the Raymarine website: <https://bit.ly/rym-recycling>

## IMO and SOLAS

The equipment described within this document is intended for use on leisure marine boats and workboats NOT covered by International Maritime Organization (IMO) and Safety of Life at Sea (SOLAS) Carriage Regulations.

## Technical accuracy

To the best of our knowledge, the information in this document was correct at the time it was produced. However, Raymarine cannot accept liability for any inaccuracies or omissions it may contain. In addition, our policy of continuous product improvement may change specifications without notice. As a result, Raymarine cannot accept liability for any differences between the product and this document. Please check the Raymarine website to ensure you have the most up-to-date version(s) of the documentation for your product: [www.docs.raymarine.com](http://www.docs.raymarine.com)

## Publication copyright

**Copyright ©2026 Raymarine UK Ltd. All rights reserved. No parts of this material may be copied, translated, or transmitted (in any medium) without the prior written permission of Raymarine UK Ltd.**

# CHAPTER 2: DOCUMENT INFORMATION

## CHAPTER CONTENTS

- [2.1 Applicable products — page 13](#)
- [2.2 Document information — page 13](#)
- [2.3 Product documentation — page 13](#)
- [2.4 Document conventions — page 13](#)
- [2.5 Document illustrations — page 14](#)

## 2.1 Applicable products

This document is applicable to the following products:

- **RCU-1** Autopilot Remote Control, part number: A80835
- **RCU-1** Autopilot Remote Control with **WG-1** Wireless Gateway, part number: E70718

## 2.2 Document information

This document contains important information related to the installation of your Raymarine product.

The document includes information to help you:

- Plan your installation and ensure you have all the necessary equipment.
- Install and connect your product as part of a wider system of connected marine electronics.
- Troubleshoot problems and obtain technical support if required.

This and other Raymarine product documents are available to download in PDF format from [www.bit.ly/rym-docs](http://www.bit.ly/rym-docs)

## 2.3 Product documentation

The following documentation is applicable to your product:

### RCU-1 applicable documents

Document	Description
<b>87492</b>	RCU-1 Remote Autopilot Controller Installation Instructions
<b>87491</b>	RCU-1 Cradle Mounting Template
<b>81426</b>	RCU-1 Operation Instructions

### WG-1 applicable documents

Document	Description
<b>87493</b>	WG-1 Wireless Gateway Installation Instructions
<b>87496</b>	WG-1 Wireless Gateway Mounting Template.

## Related documents

Document	Description
<b>81406</b>	LightHouse 4 Advanced Operation Instructions
<b>81402</b>	p70s/p70Rs/p70/p70R Operation Instructions
<b>87281</b>	Deck Mounting Kit Installation Instructions. (Provides alternative mounting methods for the WG-1 wireless gateway).
<b>87274</b>	Pole / Rail Mount Adaptor Accessory Installation Instructions (Provides alternative mounting methods for the WG-1 wireless gateway).

## Obtain the latest documentation

This document may not reflect the latest information available for your product. Please ensure that you obtain the **latest version** of documentation for your product from the Raymarine website.

QR code	Link
	<a href="http://www.bit.ly/RCU-1-docs">www.bit.ly/RCU-1-docs</a>

## 2.4 Document conventions

The following conventions are used throughout this document.

### Formatting of user interface menus and settings.

References to menus, setting options and physical buttons are formatted using square brackets [].

#### Examples:

- “You can select your desired cartography from the *[Cartography selection]* menu.”
- “MFD apps are accessed from the *[Homescreen]*.”
- “Press the *[Home]* button to return to the Homescreen.”

## Procedures for performing specific tasks using the product's user interface.

The term “**Select**” is used to refer to the action of:

- Touchscreen control — using your finger to select a menu option or item on the screen.
- Physical buttons — Highlighting an item using the navigational controls and confirming the selection by pressing the *[OK]* button.

### Examples:

- “Select *[Ok]* to confirm your selection.”
- “Select *[Set-up]*.”

## Procedures for navigating menu hierarchies.

Menu hierarchies are used in this document to provide a quick summary on how to access a particular function or menu option.

### Examples:

- “The internal sonar module is disabled using the Fishfinder app menu: *[Menu > Set-up > Sounder Set-up > Internal Sounder]*.”
- “The internal GPS can be switched off from the GPS settings menu: *[Homescreen > Status area > Satellites > Settings > Internal GPS]*.”

## 2.5 Document illustrations

While every effort is made to ensure that the illustrations provided in this publication accurately reflect the final released product, due to editorial and production lead times, your product — and if applicable — its user interface, may differ slightly from the illustrations provided in this document, depending on product variant and date of manufacture.

All images are provided for illustration purposes only.

# CHAPTER 3: PRODUCT AND SYSTEM OVERVIEW

## CHAPTER CONTENTS

- 3.1 Product overview — page 16
- 3.2 Compatible gateway — page 16
- 3.3 Compatible autopilot systems — page 16
- 3.4 Compatible autopilot controllers — page 17
- 3.5 System example — page 17

## 3.1 Product overview

The RCU-1 is a battery powered, handheld remote autopilot controller for Evolution-Series autopilot systems.

The RCU-1 is supplied with a pre-paired WG-1 Wireless Gateway when ordering part number E70718, or can be supplied as a standalone handset (part number A80835), for systems that already include a WG-1 Wireless Gateway.



Remote control features:

- Remote autopilot control — Engage, adjust, or disengage the autopilot from anywhere onboard.
- Powered by standard or rechargeable AA batteries (2 x alkaline batteries supplied).
- Full color, direct sunlight-viewable LCD screen.
- Wireless (Bluetooth) connection via the WG-1 Wireless Gateway.
- *[Point and Go]* button — Point the remote and press the button to initiate a GoTo in that direction.
- *[Solo sailor]* mode.
- Activate Man Overboard (MOB) alarm.
- View NMEA 2000 data.
- Built in AHRS (Attitude and Heading Reference System) sensor.
- Built in alarm buzzer.

- Remains fully operational when held in the cradle.
- 30 m (98.43 ft) line-of-sight operating distance from gateway.
- Approximate “In use” battery life: 30 hours.
- Approximate storage battery life: 365 days.
- Supplied with a lanyard.

## 3.2 Compatible gateway

The RCU-1 Autopilot Remote Control is compatible with the following wireless gateway:

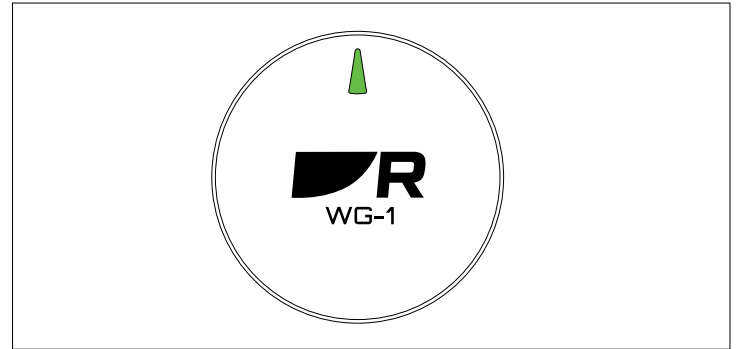

- WG-1 Wireless Gateway, part number: R70947

## 3.3 Compatible autopilot systems

Your remote control is **only** compatible with Evolution-Series autopilot systems.

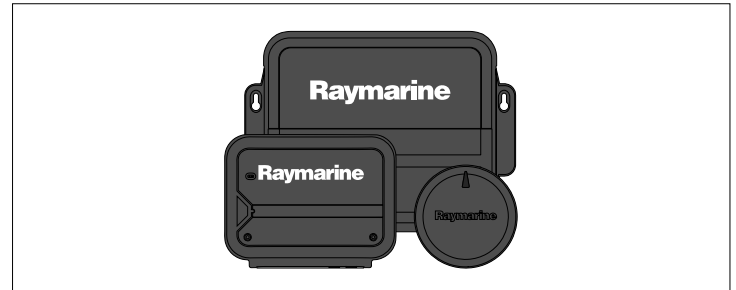

**Note:**

The EV-1 / EV-2 sensor requires software **v3.20**, or later.

**Important:**

The remote control is NOT compatible with any other Raymarine, or third-party autopilot systems.

## 3.4 Compatible autopilot controllers

The RCU-1 autopilot remote control requires a compatible autopilot controller to be connected to the system.

**Note:**

The RCU-1 cannot act as the sole autopilot control in an autopilot system.

The following autopilot controllers can be used with the remote:

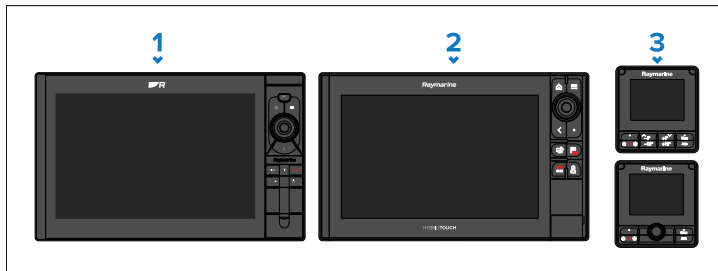

1. Axiom 2-Series chartplotters.
2. Axiom-Series chartplotters.
3. p70-Series autopilot controller.

## 3.5 System example

The following system example shows an RCU-1 Autopilot Remote Control connected to an autopilot system via the WG-1 Wireless Gateway.

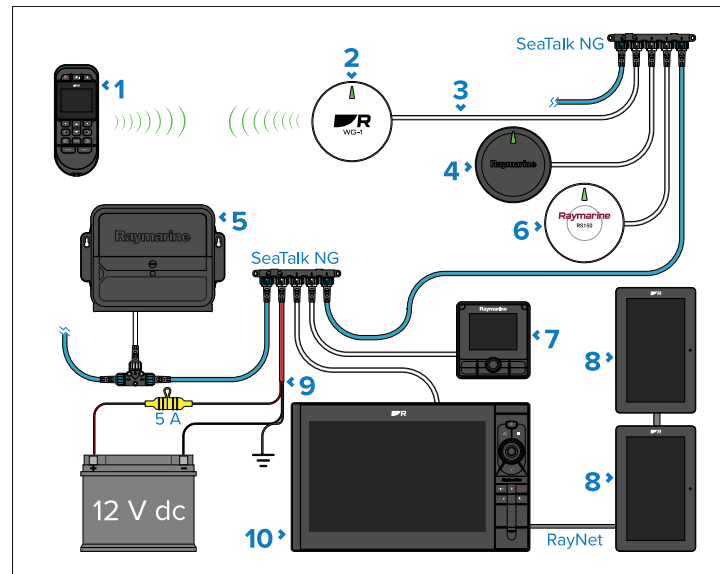

1. RCU-1 Remote Autopilot Controller.
2. WG-1 Wireless Gateway.
3. DeviceNet to SeaTalk NG adapter cable.
4. Evolution-Series sensor (e.g.: EV-1).
5. Evolution-Series ACU (e.g.: ACU-200).
6. RS150 GNSS (GPS) receiver.
7. p70Rs autopilot control head.
8. Alpha-Series displays.
9. SeaTalk NG power connection (12 V dc **only**).
10. Axiom 2 Pro chartplotter.

# CHAPTER 4: SOFTWARE DETAILS

## CHAPTER CONTENTS

- 4.1 Applicable software version — page 19
- 4.2 Compatible autopilot systems — page 19
- 4.3 Chartplotter compatibility — page 19
- 4.4 Software updates — page 19

## 4.1 Applicable software version

Product software is updated regularly to add new features and improve existing functionality.

This document has been updated to reflect the following software version:

**Applicable software version:**

v1.xx

Check the website for the latest software:

**Software download link:**

[www.bit.ly/rym-software](http://www.bit.ly/rym-software)

## 4.2 Compatible autopilot systems

Your remote control is **only** compatible with Evolution-Series autopilot systems.

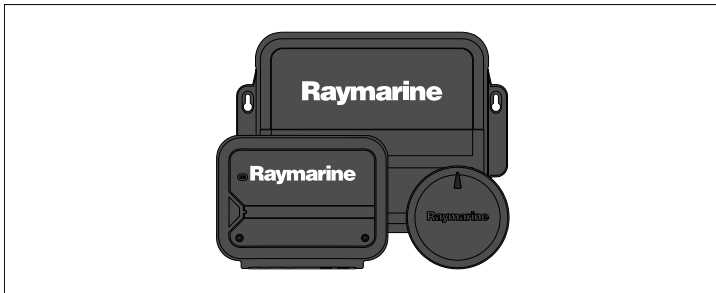

**Note:**

The EV-1 / EV-2 sensor requires software **v3.20**, or later.

**Important:**

The remote control is NOT compatible with any other Raymarine, or third-party autopilot systems.

## 4.3 Chartplotter compatibility

Axiom-Series and Axiom 2-Series chartplotters are compatible with the RCU-1 autopilot remote control.

**Note:**

Axiom-Series and Axiom 2-Series chartplotters require LightHouse 4 v4.11.103, or later.

## 4.4 Software updates

Product software updates may be made available which add new features and improve existing functionality. It's important to ensure that you have the latest software for your products by regularly checking the Raymarine website for new software releases.

To check for the latest software updates and the software update procedure for your specific product(s), refer to:

[www.bit.ly/rym-software](http://www.bit.ly/rym-software)

Unless otherwise stated, software updates for Raymarine products are performed using a Raymarine MFD / chartplotter.

- Where applicable, you should always backup your user data and settings before performing a software update.
- To update SeaTalk NG products, you must use the datamaster MFD / chartplotter which is physically connected to the SeaTalk NG backbone.
- Ethernet (RayNet) products can be updated from any MFD / chartplotter on the same network as the product to be updated.
- In order to perform a software update, any connected Autopilot or Radar must be switched to Standby.
- The MFD / chartplotter "Check online" feature is only available when connected to the Internet.

**Note:**

If in doubt as to the correct procedure for updating your product software, refer to your dealer or Raymarine technical support.

### Caution: Installing software updates

- The software update process is carried out at your own risk. Before initiating the update process ensure you have backed up any important files.
- Ensure that the product(s) has a reliable power supply and that the update process is not interrupted.
- Damage caused by an incomplete update is not covered by Raymarine warranty.
- By downloading the software update package, you agree to these terms.

Ensure that both the *[WG-1 Wireless Gateway]* and the *[Wireless Gateway Bridge]* are updated with the same software version.

### Updating software

This product's software can be updated using a connected LightHouse 4 chartplotter.

Refer to the *Software details* chapter of the LightHouse 4 Advanced Operation Instructions (document number: 81406) for details.

### Updating multiple remotes

For systems that contain multiple remotes, each remote should be updated individually.

#### Important:

- Power off any additional remotes before starting the software update. Update each remote individually, ensuring only one remote is powered on during each update process.
- Failure to update remotes individually may result in prolonged software update times and the possibility of a process timeout occurring.

### Wireless gateway software update

The gateway appears as 2 devices in the available software list. Both devices must be updated.

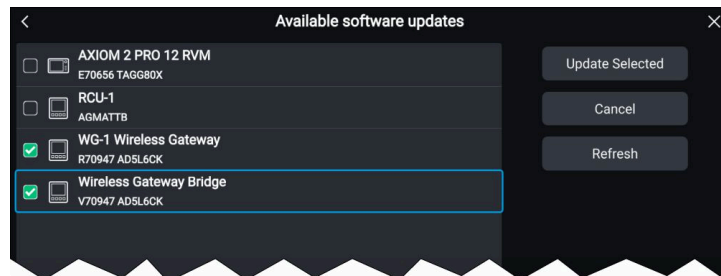

# CHAPTER 5: GETTING STARTED

## CHAPTER CONTENTS

- 5.1 Inserting batteries — page 22
- 5.2 Connecting the lanyard — page 22
- 5.3 Using the cradle — page 22
- 5.4 Controls — page 23
- 5.5 Powering on the remote — page 24
- 5.6 Powering off the remote — page 24
- 5.7 Initial setup — page 24
- 5.8 Screen overview — page 25
- 5.9 Adjusting the display brightness — page 25
- 5.10 Brightness page — page 26
- 5.11 Keylock — page 26
- 5.12 Switching to night mode — page 26
- 5.13 Calibrating the internal sensors — page 27
- 5.14 Setting data responsiveness — page 27
- 5.15 Setting the remote performance — page 27

## 5.1 Inserting batteries

Use the supplied AA batteries to power the remote.

Before inserting the supplied batteries remove any protective packaging.

### Note:

- Only use AA batteries to power the remote.
- Alkaline, Lithium or rechargeable batteries are recommended.
- It is also recommended that you purchase a spare pair of suitable AA batteries to limit any operational interruptions due to depleted batteries.

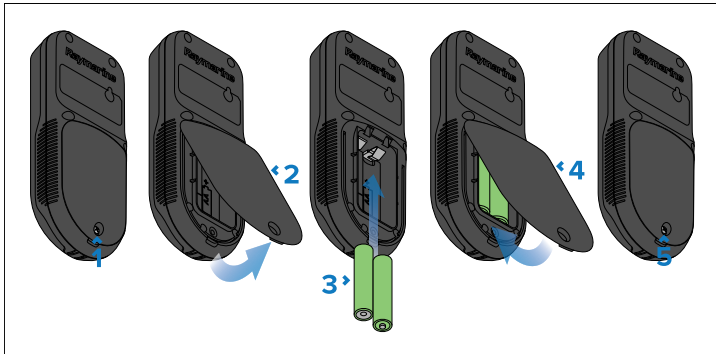

1. Unscrew the captive battery cover screw.
2. Remove the battery cover by pivoting the bottom of the cover away from the remote control.
3. Ensuring correct orientation, insert the new batteries.  
*Correct battery orientation is indicated in the battery compartment, and is viewable when no batteries are fitted.*
4. Replace the battery cover by inserting the top lugs into the remote control at a slight angle, and then push the bottom of the cover to its closed position.
5. Re-tighten the battery cover screw.

## 5.2 Connecting the lanyard

The supplied lanyard should be connected to the remote control.

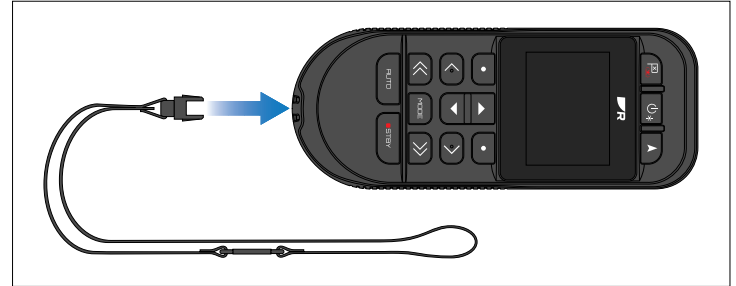

1. Insert the end of the Lanyard into the holes located on the bottom of the remote control.

## 5.3 Using the cradle

When the remote is not in use it should be inserted in its cradle.

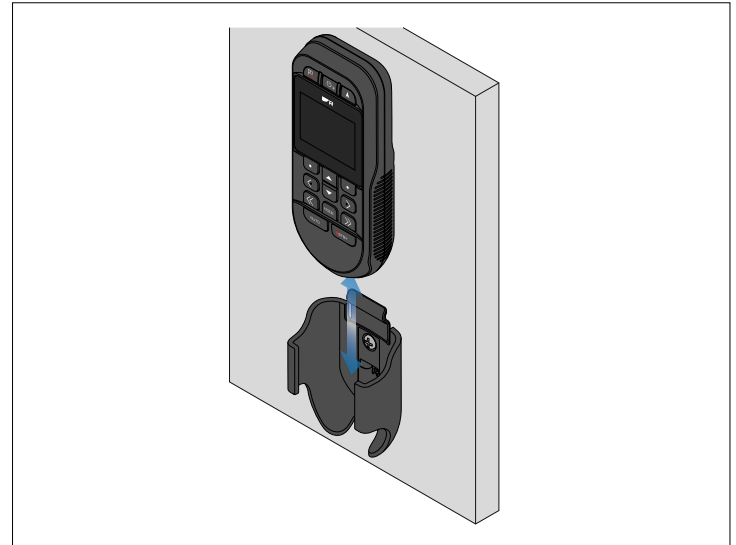

- **Inserting the remote:** Gently **push** the remote in a **downward** motion into the cradle, ensuring that the remote is pushed down

fully into the cradle. The remote remains fully operational while in its cradle.

- **Removing the remote:** Gently **pull** the remote in an **upward** motion out of the cradle.

## 5.4 Controls

The RCU-1 has physical buttons which are used to interact with the remote's user interface. The details below describe the buttons and their functions.

### General usage:

- Buttons 2, and 7 to 13 are used to control the autopilot.
- Buttons 3 to 6 are used to control the remote's user interface.

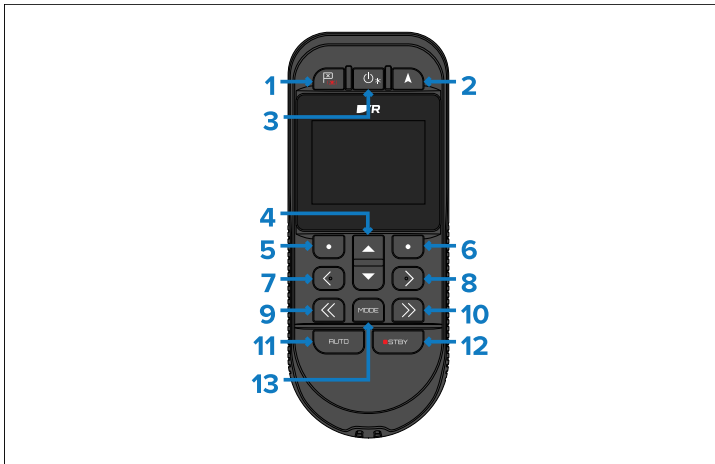

Description	
1	<i>[Waypoint / MOB]</i> — Press momentarily to place a waypoint at your vessel's location. A long press activates the Man Overboard (MOB) alarm.
2	<i>[Point and Go]</i> — Press to capture the remote's current bearing and place a <i>[GoTo]</i> at a defined distance.

Description	
3	<i>[Power]</i> <ul style="list-style-type: none"> <li>• Press to power on.</li> <li>• When powered on, press to open the <i>[Brightness]</i> page. With the <i>[Brightness]</i> page displayed, pressing the <i>[Power]</i> button again increases the brightness in increments.</li> <li>• Press and hold to power off.</li> </ul>
4	<i>[Up] / [Down]</i> — Use these buttons to move through menus, modify numeric settings, or adjust brightness from the Brightness page.
5	<i>[Left Softkey]</i> — The button's action is context-dependent, and is identified on the screen above the button.
6	<i>[Right Softkey]</i> — The button's action is context-dependent, and is identified on the screen above the button.
7	<i>[&lt;]</i> (Left 1°) — Change Heading, Rudder angle, or Wind direction offset to port by 1° (one degree).
8	<i>[&gt;]</i> (Right 1°) — Change Heading, Rudder angle, or Wind direction offset to starboard by 1° (one degree).
9	<i>[&lt;&lt;]</i> (Left 5° / 10°) <ul style="list-style-type: none"> <li>• Change Heading, or Wind direction offset to port by 10° (ten degrees).</li> <li>• Increase rudder angle to port by 5° (five degrees)</li> </ul>
10	<i>[&gt;&gt;]</i> (Right 5° / 10°) <ul style="list-style-type: none"> <li>• Change Heading, or Wind direction offset to starboard by 10° (ten degrees).</li> <li>• Increase rudder angle to starboard by 5° (five degrees)</li> </ul>
11	<i>[AUTO]</i> — Press to engage the autopilot in <i>[Steer to Heading mode]</i> .
12	<i>[STBY]</i> — Press to disengage the autopilot.
13	<i>[MODE]</i> — Press to open the autopilot modes menu.

## 5.5 Powering on the remote

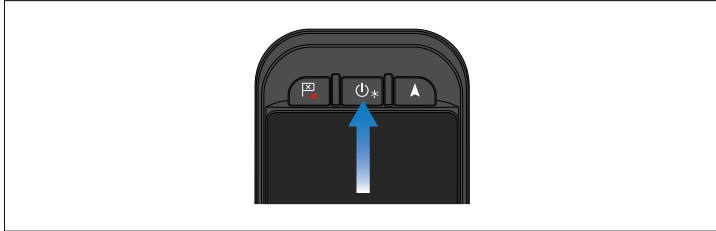

1. Press the *[Power]* button to power on the remote.

The remote will beep and after a few seconds the *[Terms]* of use page will be displayed.

Once the *[Terms]* page has been accepted the first default data page will be displayed.

## 5.6 Powering off the remote

With the remote powered on:

1. Press and hold the *[Power]* button for approximately 2 seconds, until the powering down message is displayed onscreen.

## 5.7 Initial setup

### User interface languages

The remote's user interface language can be changed from the *[Settings]* menu *[Menu > Settings > Language]*.

The available user interface languages are:

Languages			
Chinese (Simplified) (zh-CN)	Croatian (hr-HR)	Danish (da-DK)	Dutch (nl-NL)
English (en-GB)	English (en-US)	Finnish (fi-FI)	French (fr-FR)
German (de-DE)	Greek (el-GR)	Italian (it-IT)	Japanese (ja-JP)

Languages			
Korean (ko-KR)	Norwegian (nb-NO)	Polish (pl-PL)	Portuguese (Brazilian) (pt-BR)
Russian (ru-RU)	Spanish (es-ES)	Swedish (sv-SE)	Turkish (tr-TR)

The selected language also determines the display's default units of measure.

### Manual Bluetooth pairing

The remote control must be paired with the wireless gateway.

If your RCU-1 Autopilot Remote Control and WG-1 Wireless Gateway were purchased as a system pack (E70718), the remote control will be pre-paired to the wireless gateway. The remote control will automatically connect with the wireless gateway when it is powered on.

If you have purchased your remote control and wireless gateway separately (e.g. as a spare or accessory), the remote control will need to be manually paired to the wireless gateway.

When the remote is powered on, after accepting the *[Terms]* page, the remote will automatically start searching for wireless gateways.

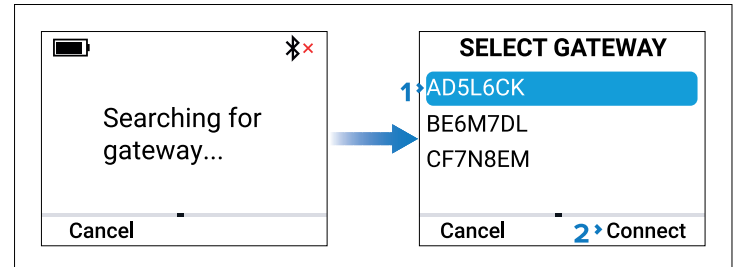

1. Use the *[Up]* and *[Down]* buttons to highlight your wireless gateway in the list of devices.

*If more than one gateway is discovered, you can identify its serial number by checking its product label, or by checking the list of networked devices on a compatible chartplotter's Network settings menu: *[Homescreen > Settings > Network]*.*

- Press the *[Connect]* (Right softkey) button.

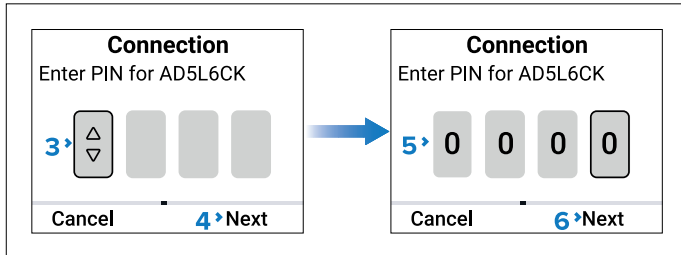

- Enter the first digit of the PIN, using the *[Up]* and *[Down]* buttons.

**Note:**

The wireless gateway's PIN number is: **0000**.

- Press the *[Next]* (Right softkey) button.
- Repeat steps 3 and 4 for the remaining 3 PIN digits.
- After entering the fourth digit of the PIN, pressing the *[Next]* button will initiate the connection.

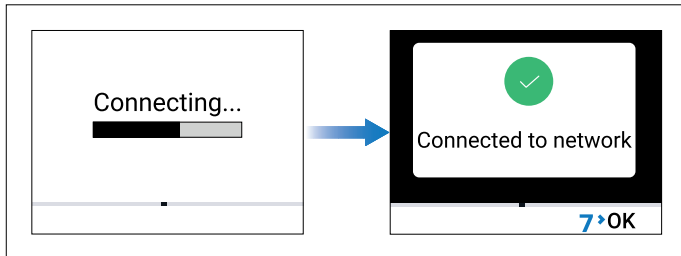

- Press the *[OK]* button when the "Connected to network" message is displayed.

**Note:**

If the pairing process fails, re-check the wireless gateway's PIN number, power cycle the wireless gateway and the remote control, and then re-attempt pairing.

## 5.8 Screen overview

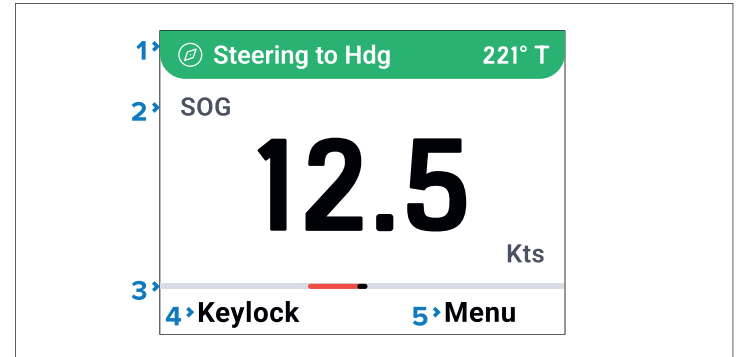

- Autopilot status bar — The bar identifies the current pilot mode and expands when the *[MODE]* button is pressed so that an autopilot mode can be selected.
- Main window — The main window is used to display data pages, notifications and menus.
- Rudder indicator bar — The bar indicates rudder position.
- [Left soft]* button — Identifies the action assigned to the *[Left soft]* button
- [Right soft]* button — Identifies the action assigned to the *[Right soft]* button

The actions assigned to the *[Left soft]* button and *[Right soft]* button are context sensitive.

## 5.9 Adjusting the display brightness

The display backlight can be adjusted from the *[BRIGHTNESS]* page.

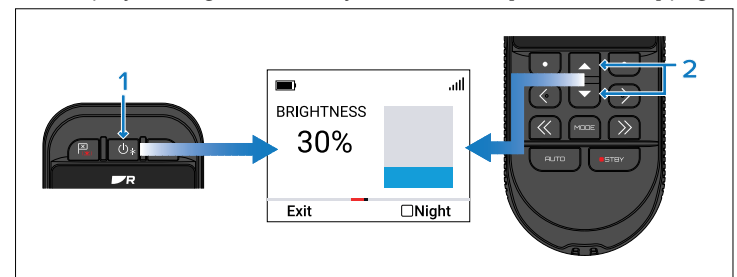

1. Press the *[Power]* button to open the *[BRIGHTNESS]* page.
2. Use the *[Up]* and *[Down]* buttons to adjust the display brightness in 10% increments.

With the *[BRIGHTNESS]* page displayed, the brightness can also be increased in 25% increments each time the *[Power]* button is pressed. This is useful to quickly adjust the brightness for daylight viewing, when the display is set for night time viewing. The *[BRIGHTNESS]* page will timeout after approximately 5 seconds of inactivity.

## 5.10 Brightness page

Pressing the *[Power]* button opens the *[BRIGHTNESS]* page.

The *[BRIGHTNESS]* page includes the following:

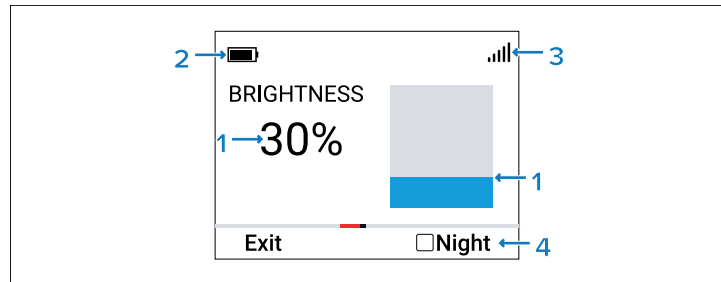

1. Brightness level.
2. Battery power level.
3. Bluetooth connection signal strength.
4. Night mode.

## 5.11 Keylock

The remote's buttons can be locked to prevent accidental operations.

By default, *[Keylock]* is assigned to the *[Left soft]* button. If a different shortcut has been assigned to the *[Left soft]* button *[Keylock]* can be activated from the *[Shortcut key]* menu: *[Menu > Settings > Shortcut keys > Lock keypad]*.

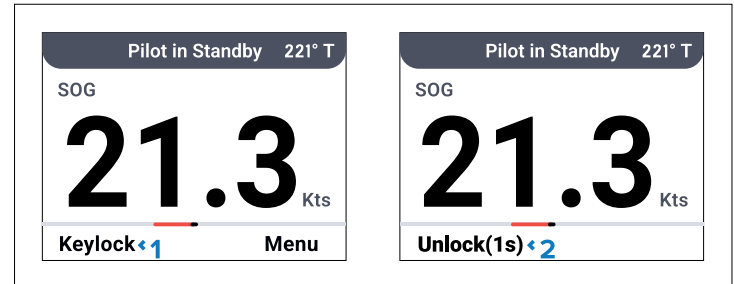

1. *[Keylock]* (Left soft) button — Press to activate *[Keylock]*.
2. *[Unlock(1s)]* (Left soft) button — Press for 1 second to deactivate *[Keylock]*.

While *[Keylock]* is active the *[STBY]* (Standby) button remains enabled and a Man Overboard can be triggered using the *[Waypoint/MOB]* button.

## 5.12 Switching to night mode

The remote includes a *[Night]* mode which reduces the display brightness and changes the color theme to a darker color palette, making the display easier to read at night.

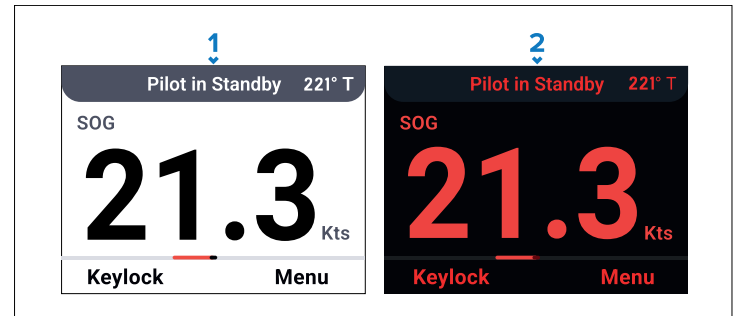

1. *Day (default)*
2. *Night*

To switch to *[Night]* mode.

1. Press the *[Power]* button to open the *[BRIGHTNESS]* page.
2. Press the *[Night]* (Right soft) button to activate *[Night]* mode..

Switching between Night and Day modes will cause the remote to reboot, the autopilot operation will not be affected.

With the *[BRIGHTNESS]* page displayed, the brightness can also be increased in 25% increments each time the *[Power]* button is pressed. This is useful to quickly adjust the brightness for daylight viewing, when the display is set for night time viewing.

In *[Night]* mode once 100% brightness is reached the next press of the *[Power]* button will deactivate *[Night]* mode.

The *[BRIGHTNESS]* page will timeout after approximately 5 seconds of inactivity.



### Warning: Day mode brightness warning

Switching from Night mode to Day mode instantly increases the display brightness to maximum. This will impact the operator's night vision, due to the relative brightness of Day mode in night time conditions.

## 5.13 Calibrating the internal sensors

The remote includes an internal magnetometer which may require calibration from time to time.

To perform magnetometer calibration:

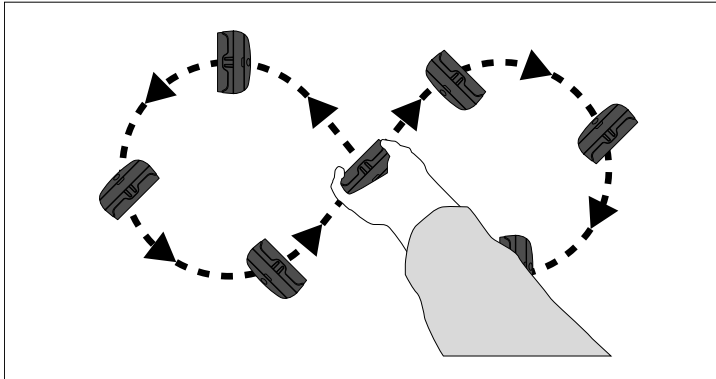

1. Select *[Settings]* from the main menu.
2. Select *[Calibrate compass]*.
3. To calibrate the sensor, move the remote in a continuous figure-eight motion while rotating it to maintain alignment with the direction of travel.

## 5.14 Setting data responsiveness

*[Data responsiveness]* determines how quickly the data displayed onscreen is changed when changes occur in data received from connected devices. Setting the *[Data responsiveness]* to a low value will dampen data fluctuations to provide a more stable reading. Setting the *[Data responsiveness]* to a higher value will reduce the damping and make readings more responsive.

1. Select *[Settings]* from the main menu.
2. Select *[Data responsiveness]*.
3. Use the *[Up]* and *[Down]* buttons to adjust the *[Data responsiveness]*.

Data responsiveness can be set between 1 and 10 with 5 being the default value.

## 5.15 Setting the remote performance

The *[Performance]* setting determines the performance of the remote's battery saving settings.

1. Select *[Settings]* from the main menu.
2. Select *[Performance]*.
3. Select *[Backlight]* and use the *[Up]* and *[Down]* buttons to adjust the time in seconds before the display turns off when inactive.
4. Select *[Save]*.
5. Select *[Sleep]* and use the *[Up]* and *[Down]* buttons to adjust the time in minutes before the remote enters *[Sleep]* mode when inactive.
6. Select *[Save]*.
7. Select *[Power off]* and use the *[Up]* and *[Down]* buttons to adjust the time in hours before the remote is automatically powered off when inactive.
8. Select *[Save]*.

# CHAPTER 6: AUTOPILOT MODES

## CHAPTER CONTENTS

- 6.1 Supported autopilot modes — page 29
- 6.2 Unsupported autopilot modes — page 29
- 6.3 Disengaging the autopilot — STBY — page 29
- 6.4 Engaging the autopilot — Steer to Heading (AUTO) — page 29
- 6.5 Engaging the autopilot — Steer to Navigation — page 30
- 6.6 Engaging the autopilot — Steer to Wind — page 30
- 6.7 Engaging the autopilot — Power steer — page 31
- 6.8 Steer to Heading — page 31
- 6.9 Steer to Navigation — page 32
- 6.10 Steer to wind modes — page 35
- 6.11 Power steer — page 39

## 6.1 Supported autopilot modes

Autopilot modes are accessed by pressing the *[MODE]* button. The following modes are supported:

- *[Steer to Heading]*— The autopilot will automatically maintain the vessel's current heading. This mode is available for all vessel types.
- *[Steer to Navigation]*— The autopilot will automatically steer the vessel to a waypoint or follow a route set from a Raymarine chartplotter. This mode is available for all vessel types.
- *[Steer to Wind(A)]*— The autopilot will use AWA (Apparent Wind Angle) to maintain a fixed wind angle to the wind, at any point of sail. **This mode is only available for sailing vessel types**, and requires wind data to be available.
- *[Steer to Wind(T)]*— The autopilot will use TWA (True Wind Angle); calculated from AWA (Apparent Wind Angle) and STW (Speed Through Water) to maintain a fixed wind angle to the wind at any point of sail. **This mode is only available for sailing vessel types**, and requires wind data to be available.
- *[Steer to Polar]*— The autopilot will use the polar table configured on a Raymarine chartplotter to achieve optimum upwind (or downwind) performance, based on the polar table data. **This mode is only available for sailing vessel types**, and requires wind data to be available.
- *[Power Steer]*— The autopilot will command the rudder directly. **This mode is only available for power boat types / vessel hull types**.

## 6.2 Unsupported autopilot modes

The following autopilot modes are NOT supported by the remote:

- *[Pattern]*
- *[Jog Steer]*

If an unsupported mode is engaged from a pilot controller or chartplotter, the remote screen will indicate the pilot mode, however the Override *[Left °]*, *[Right °]*, *[Left 10°]* and *[Right 10°]* buttons will be disabled.

## 6.3 Disengaging the autopilot — STBY

When the autopilot is engaged in any mode it can be disengaged from the remote.

Ensure you are ready to take manual control before disengaging the autopilot.

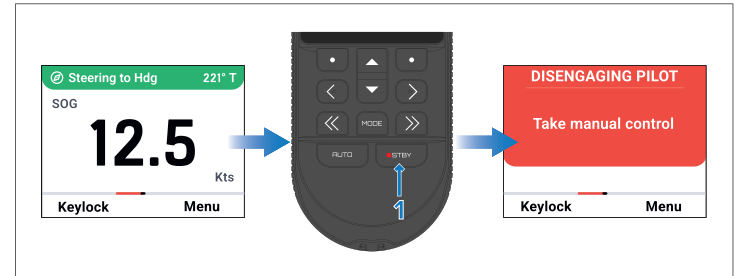

1. Press the *[STBY]* button.

## 6.4 Engaging the autopilot — Steer to Heading (AUTO)

When the *[AUTO]* button is pressed the autopilot will engage *[Steer to Heading]* mode. This mode is also commonly referred to as “Locked Heading” mode.

For Wheel and Tiller pilots, ensure that the mechanical drive is engaged by either engaging the wheel drive's clutch or attaching the pushrod onto the tiller pin.

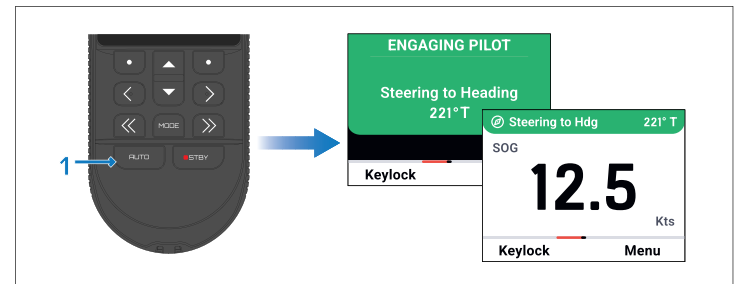

1. Press and hold the *[AUTO]* button

*Steer to Heading* mode can also be engaged by pressing the *[Mode]* button and selecting *[Steer to Heading]*.

## 6.5 Engaging the autopilot — Steer to Navigation

When there is active navigation on a connected chartplotter the remote can engage the autopilot in *[Steer to Navigation]* mode.

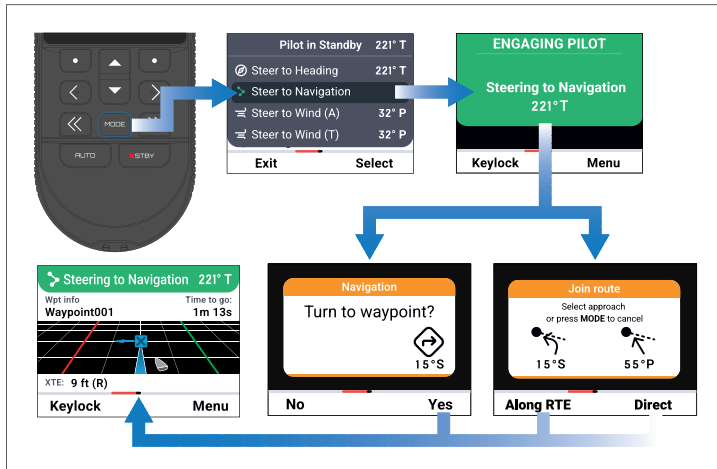

To engage your autopilot in *[Steer to Navigation]* mode:

1. For Wheel and Tiller pilots, engage the mechanical drive by either engaging the wheel drive's clutch or attaching the pushrod onto the tiller pin.
2. Initiate a *[Goto]* or *[Follow route]* on your chartplotter. For more information, refer to the *LightHouse 4 Advanced Operation Instructions (81406)*.

### Important:

It is the captain's responsibility to ensure a route is safe to navigate before commencing the follow.

3. Press the *[MODE]* button.
4. Select *[Steer to Navigation]*.
  - If navigation is to a single waypoint, or your current cross track error is less than 30 m from the first waypoint in a route the *[Turn to waypoint]* notification is displayed.

- If your current cross track error is greater than 30 m from the first waypoint in a route the *[Join route]* notification is displayed.
5. If the *[Turn to waypoint]* notification is displayed, select the *[Yes]* (Right soft) button to engage the autopilot, or
  6. If the *[Join route]* notification is displayed:
    - Select the *[Along RTE]* (Left soft) button to engage the autopilot and steer your vessel back to its original track, or
    - Select the *[Direct]* (Right soft) button to engage the autopilot, restarting the track from your current position.

When *[Steer to Navigation]* is engaged the *[Navigation]* page will be displayed. For details refer to: [p.32 — Navigation page](#)

## 6.6 Engaging the autopilot — Steer to Wind

*[Steer to Wind]* modes can be engaged from the remote.

### Note:

For the *[Steer to Wind]* modes to be available:

- Wind and Heading data must be available on the network.
- Your autopilot must be configured as a sailing *[Boat type]* / *[Vessel hull type]*. Refer to the commissioning instructions for your autopilot for details on how to configure the *[Boat type]* / *[Vessel hull type]*.
- *[Steer to Polar]* mode requires a valid polar table to be configured on your chartplotter.
- *[Steer to Polar]* also requires the wind angle to be within 30° of the polar target.

## Example Steering to Wind (A)

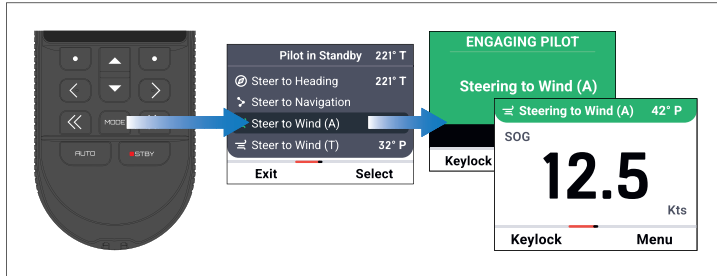

1. For Wheel and Tiller pilots, engage the mechanical drive by either engaging the wheel drive's clutch or attaching the pushrod onto the tiller pin.
2. Press the *[MODE]* button.
3. Select your desired *[Steer to Wind]* mode:  
*[Steer to Wind (A)]*, *[Steer to Wind (T)]*, or *[Steer to Polar]*.

## 6.7 Engaging the autopilot — Power steer

The remote can command the rudder directly.

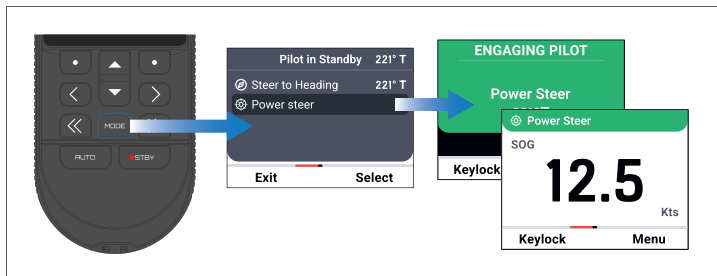

1. Press the *[MODE]* button.
2. Select *[Power steer]*.

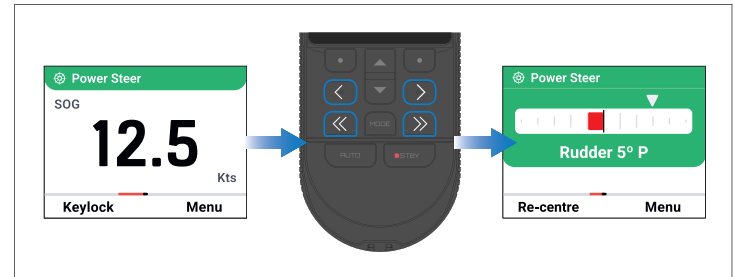

You can now use the *[Left]* and *[Right]* buttons to steer the vessel.

## 6.8 Steer to Heading

In *[Steer to Heading]* mode, your autopilot follows a locked heading. While in *[Steer to Heading]* mode the following options are available from the remote:

- Change autopilot mode — Press the *[MODE]* button to switch to a different autopilot mode.
- Change the current locked heading — Use the *[Left]* and *[Right]* buttons to adjust the locked heading.
- Disengage the autopilot — Press the *[STBY]* (Standby) button to resume manual steering.

### Adjusting locked heading

In *[Steer to Heading]* mode the remote can be used to change the locked heading.

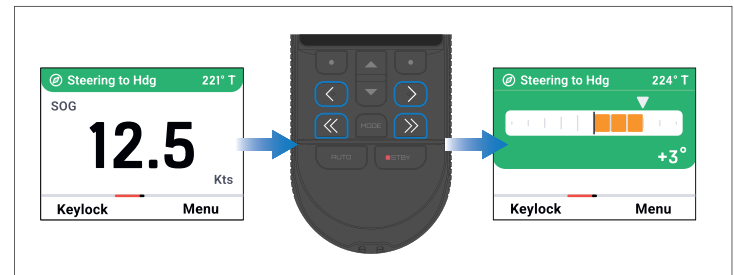

1. Use the adjustment buttons to change the locked heading:
  - *[<]* (Left 1°) — Each press will change the locked heading by 1° to the left.

- [ $\ll$ ] (Left 10°) — Each press will change the locked heading by 10° to the left.
- [ $\gg$ ] (Right 1°) — Each press will change the locked heading by 1° to the right.
- [ $\gg$ ] (Right 10°) — Each press will change the locked heading by 10° to the right.

## 6.9 Steer to Navigation

In *[Steer to Navigation]* mode, your autopilot will navigate to a waypoint, GoTo, or follow a route that has been initiated from your chartplotter.

When *[Steer to Navigation]* is initiated the *[Navigation page]* is displayed. While in *[Steer to Navigation]* mode the following options are available from the remote:

- Change autopilot mode — Press the *[MODE]* button to select a different autopilot mode.
- Switch to *[Steer to Heading]* — Press the *[AUTO]* button to switch to *[Steer to Heading]* mode.
- Change the current heading — Use the *[Left]* and *[Right]* buttons to adjust the locked heading.
- Disengage the autopilot — Press the *[STBY]* (Standby) button to resume manual steering.

## Navigation page

The *[Navigation page]* can be added as a data page. The *[Navigation page]* shows information about the vessel's progress towards a target waypoint.

### Navigation page overview

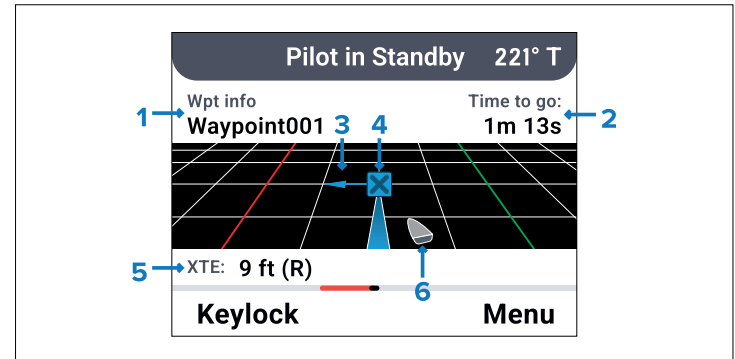

The *[Navigation page]* provides the following navigation details:

1. Waypoint name.
2. Time to go.
3. Next waypoint direction (applicable for routes).
4. Target waypoint.
5. XTE (Cross track error) (if applicable).
6. Vessel position.

#### Note:

An arrow indicating whether you are to the right or left of the track will be shown instead of the vessel icon, if the current cross track error is greater than the value configured in your pilot controller's, or chartplotter's cross track error alarm.

## Overriding navigation

*[Steer to Navigation]* mode can be temporarily overridden so that an obstacle can be avoided without disengaging the autopilot.

If an obstacle is in your path follow the steps below to override navigation:

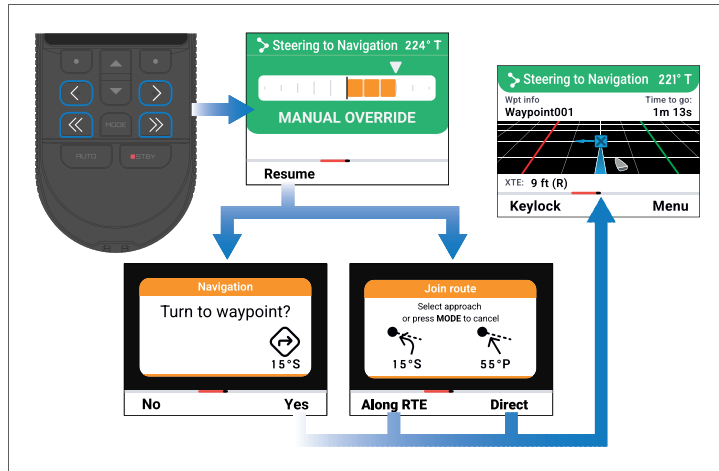

- Use the adjustment buttons to override navigation and change your heading to avoid the obstacle:
  - [<] (Left 1°) — Each press will change the autopilot's course by 1° to the left.
  - [<<] (Left 10°) — Each press will change the autopilot's course by 10° to the left.
  - [>] (Right 1°) — Each press will change the autopilot's course by 1° to the right.
  - [>>] (Right 10°) — Each press will change the autopilot's course by 10° to the right.
- Press the [Resume] (Left soft) button once you are clear of the obstacle.  
If applicable, the [Turn to waypoint], or [Join route] notification will be displayed.
- If the [Turn to waypoint] notification is displayed, select the [Yes] (Right soft) button to engage the autopilot, or
- If the [Join route] notification is displayed:
  - Select the [Along RTE] (Left soft) button to engage the autopilot and steer your vessel back to its original track, or
  - Select the [Direct] (Right soft) button to engage the autopilot, restarting the track from your current position.

[Steer to Navigation] will recommence.

Autopilot modes

## Cross Track Error (XTE)

Cross Track Error (XTE) occurs when your vessel is steered or drifts off its original course (track). The distance between your original course and your current position is the cross track error (XTE).

The XTE is relative to the track and not the vessel heading, therefore XTE values are specified in terms of distance to the left or right of the track.

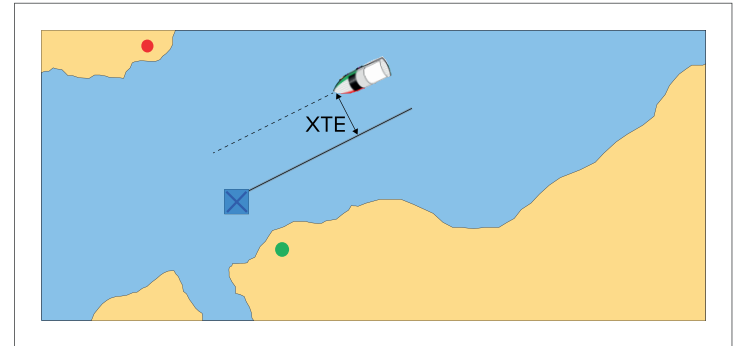

When an XTE exists you can steer your vessel back on to its original track, or you can restart the XTE value and use your current position as the starting point for a new track.

### Restarting cross track error

When a cross track error (XTE) exists it can be restarted

- Press the [Menu] (Left soft) button.
- Select [Restart XTE].  
The [Turn to waypoint] notification is displayed.
- Press the [Yes] (Right soft) button.

A new track will be created from your current position to the target waypoint.

### Waypoint arrival and route complete

In [Steer to Navigation] mode, when you reach a target waypoint a notification is displayed.

You are deemed to have arrived at a waypoint when your vessel reaches the distance from the waypoint as specified in your chartplotter's [Arrival radius (pilot in track mode)] setting.

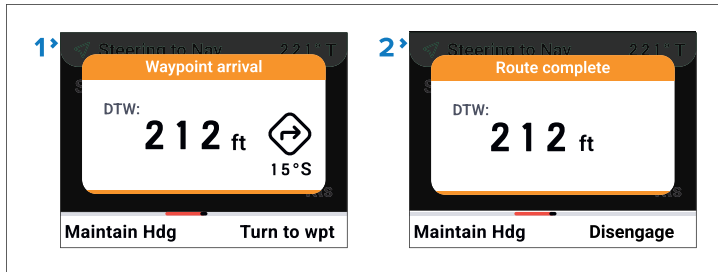

1. **Waypoint arrival notification** — When arriving at an interim waypoint in a route the *[Waypoint arrival]* notification is displayed. The Waypoint arrival notification will include the remaining Distance To the Waypoint (DTW) and the turn angle required for the next waypoint. The options available to you are:
  - **Maintain heading** — Select the *[Maintain Hdg]* (Left soft) button to switch to *[Steer to Heading]* mode.
  - **Turn to the waypoint** — Select the *[Turn to wpt]* (Right soft) button to turn towards the next waypoint in the route.
  - **Disengage the autopilot** — Press the *[STBY]* button to resume manual steering.
2. **Route complete notification** — When arriving at a target *[GoTo]* waypoint, or to the final waypoint in a route the *[Route complete]* notification is displayed. The Route complete notification will include the remaining Distance To the Waypoint (DTW). The options available to you are:
  - **Maintain heading** — Select the *[Maintain Hdg]* (Left soft) button to switch to *[Steer to Heading]* mode.
  - **Disengage the autopilot** — Press the *[Disengage]* (Right soft) button to resume manual steering.

## Automatic turning

If *Automatic turning* is configured on your chartplotter, the autopilot will automatically turn to the next waypoint when following a route in *[Steer to Navigation]* mode, once the vessel reaches the distance specified in the chartplotter's *[Arrival Radius (pilot in track mode)]* setting.

### Note:

- *Automatic turning* is not available when the chartplotter has been configured with the “Sailing” boating activity.
- For details on configuring *Automatic turning* refer to the *LightHouse 4 Operation instructions* (Document number 81406).

A notification is displayed informing you that *Automatic turning* will commence.

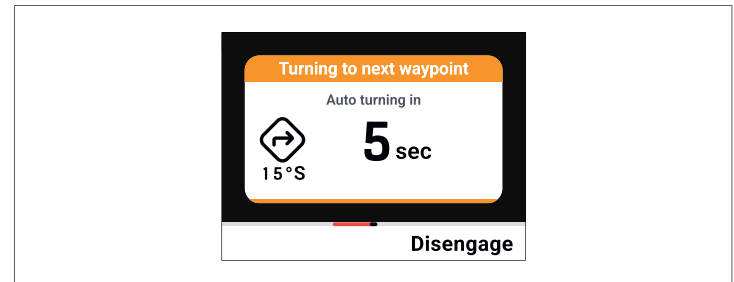

The notification includes a countdown. When the countdown reaches zero the vessel will turn.

If you do not want the vessel to turn select the *[Disengage]* (Right soft) button to resume manual steering.

## Advance waypoint

When following a route in *[Steer to Navigation]* mode, if the current target waypoint is not the final waypoint in the route the *[Advance waypoint]* setting will be available in the main menu.

Selecting *[Advance waypoint]* will display a confirmation notification.

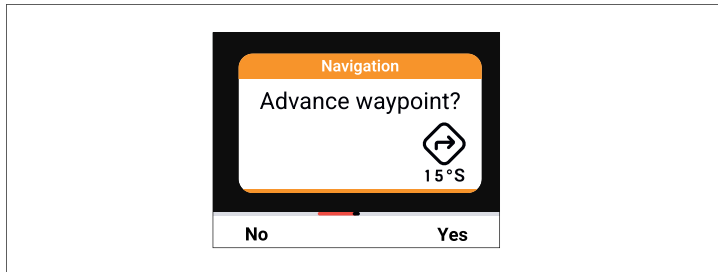

Selecting the *[Yes]* (Right soft) button will skip the current target waypoint and commence navigation to the next waypoint in the route.

## 6.10 Steer to wind modes

Steer to wind modes use your autopilot to steer your vessel to the wind. You can steer either to the Apparent Wind Angle (AWA), True Wind Angle (TWA), or to a target wind angle from a polar table.

### Note:

For the *[Steer to Wind]* modes to be available:

- Wind and Heading data must be available on the network.
- Your autopilot must be configured as a sailing *[Boat type]* / *[Vessel hull type]*. Refer to the commissioning instructions for your autopilot for details on how to configure the *[Boat type]* / *[Vessel hull type]*.
- *[Steer to Polar]* mode requires a valid polar table to be configured on your chartplotter.
- *[Steer to Polar]* also requires the wind angle to be within 30° of the polar target.

The wind modes available depend on the selected *[Sail performance]* setting in your chartplotter's *[Boat details]* menu.

The available wind modes are:

- *[Steer to Wind (T)]* — Use the True Wind Angle (TWA) to maintain a fixed wind angle to the wind, at any point of sail.
- *[Steer to Wind (A)]* — Use the Apparent Wind Angle (AWA) to maintain a fixed wind angle to the wind, at any point of sail.

- *[Steer to Polar]* — Only available when the chartplotter's *[Sail performance]* settings is set to *[Polar]*. Use *[Steer to Polar]* to achieve optimum upwind (or downwind) performance based on your polar table.

## Mirrored TWA and Fixed angles

When your chartplotter's *[Sail performance]* is set to either *[Mirrored TWA]* or *[Fixed angles]* the TWA and AWA steer to wind modes will be available.

When using the TWA mode or AWA mode the vessel will automatically steer towards the selected wind angle. The wind angle can be adjusted in 1° or 10° increments using the relevant buttons. If a wind shift occurs, the autopilot will adjust the locked heading to maintain the original wind angle.

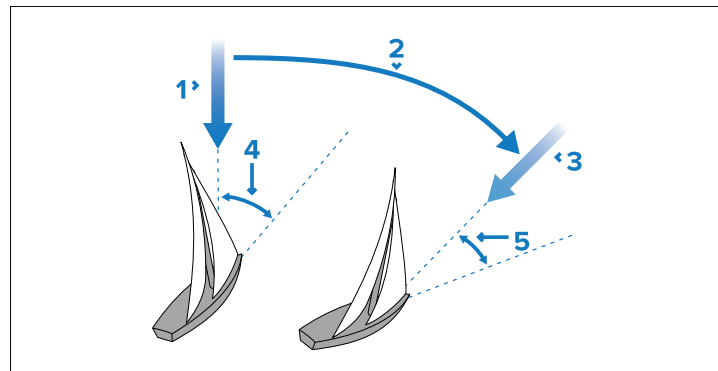

1. Initial wind direction.
2. Wind shift.
3. New wind direction.
4. Relative wind angle.
5. Vessel turns to maintain the same relative wind angle.

## Target wind angle from polar

When the chartplotter's *[Sail performance]* is set to *[Polar]* and the wind angle is within 30° of the polar target wind angle, the vessel will automatically steer towards the relevant TWA based on current

True Wind Speed (TWS) for *vessel speed*, as specified in your polar table. The upwind or downwind, port or starboard target wind angle is used, depending on which is closest to the current wind angle.

The system tries to use the closest target wind angle to the actual wind angle. If the target wind angle is more than plus or minus 30° from the actual wind angle, the mode cannot be enabled.

You can adjust the target wind angle in 1° increments using the relevant buttons.

If the wind shifts, or the wind angle is changed by more than 30° from the polar target, the system will revert to the previously used mode (TWA or AWA).

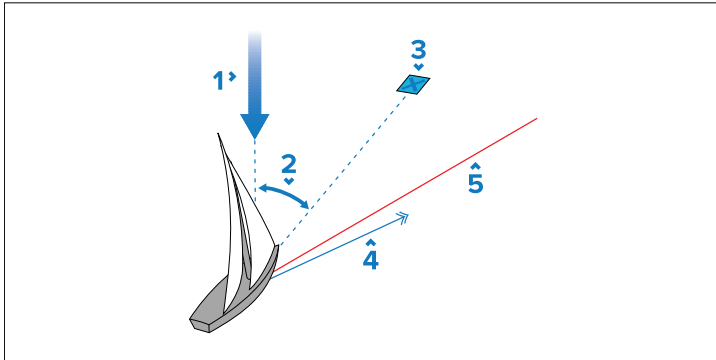

1. Wind angle.
2. Target wind angle.
3. Destination.
4. Course Over Ground (COG).
5. Layline (with *[Adjust for tides]* enabled).

## Polar performance

In *[Steer to Polar]* mode the pilot bar will include current wind angle and the performance to the polar target.

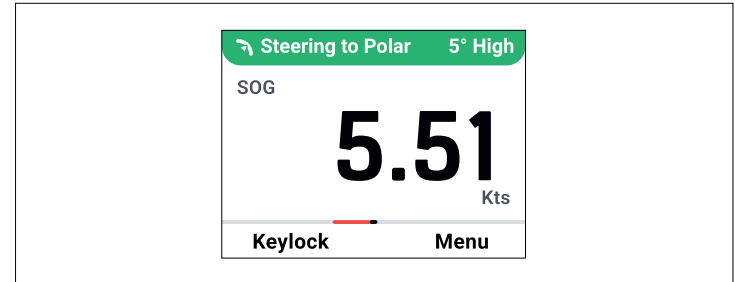

The performance values are:

- **On target** — Shown when the wind angle is on target.
- **High** — Shown when steering closer to the wind direction (while sailing upwind or downwind).
- **Low** — Shown when steering further from the wind direction (while sailing upwind).
- **Deep** — Shown when steering further from the wind direction (while sailing downwind).

## Operating hints for wind vane mode

- Always trim your sails carefully to minimize the amount of standing helm.
- Reef the headsail and mainsail a little early rather than too late.
- In Wind Vane mode the autopilot will react to long-term wind shifts, but will not correct for short-term changes such as gusts.
- In gusty and unsteady inshore conditions, it is best to sail a few degrees further off the wind so that changes in wind direction can be tolerated.

### Caution: Allow time

Always allow adequate time for course changes.

## Caution: Major course changes

When making major course changes, the trim on the boat may change substantially. Due to this, the autopilot may take some time to settle accurately onto the new course.

## Steer to Wind

While in *[Steer to Wind]* modes the following options are available from the remote:

- Change autopilot mode — Press the *[MODE]* button to change autopilot mode.
- Change the current locked wind angle — Use the *[Left]* and *[Right]* buttons to adjust the wind angle.
- Disengage the autopilot — Press the *[STBY]* (Standby) button to resume manual steering.

## Adjusting the wind angle

In *[Steer to Wind]* modes the remote can be used to change the wind angle the autopilot is steering towards.

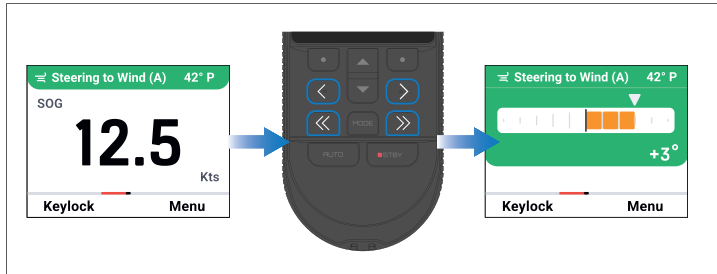

1. Use the adjustment buttons to change the current wind angle:
  - *[<]* (Left 1°) — Each press will change the wind angle by 1° to the left.
  - *[<<]* (Left 10°) — Each press will change the wind angle by 10° to the left.
  - *[>]* (Right 1°) — Each press will change the wind angle by 1° to the right.
  - *[>>]* (Right 10°) — Each press will change the wind angle by 10° to the right.

## Tacking

When sailing upwind, in *[Steer to Wind]* modes settings will be available to tack your vessel. Tacking your vessel will turn the vessel to the same offset on the opposite side of the wind

Tacking is always relative to wind angle and is not adjustable. Performing a Tack will always be through the wind.

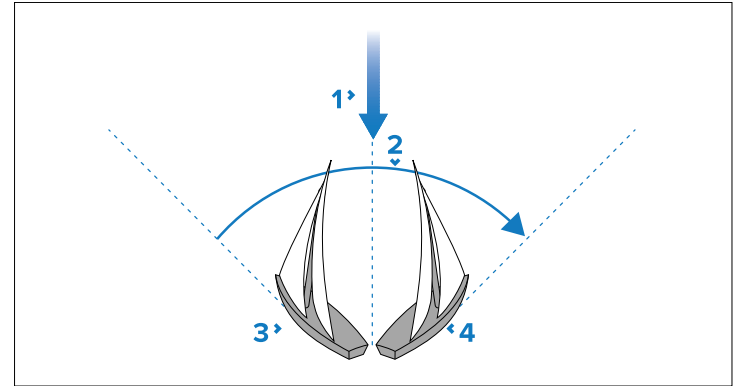

1. Wind direction.
2. Tack.
3. Starting position.
4. Final position.

## Performing a tack

Use the *[Tack]* settings to perform a *[Tack]*.

- If your current locked wind angle is to starboard, the *[Tack to port]* setting will be available.
- If your current locked wind angle is to port, the *[Tack to starboard]* setting will be available.

## Example Port tack

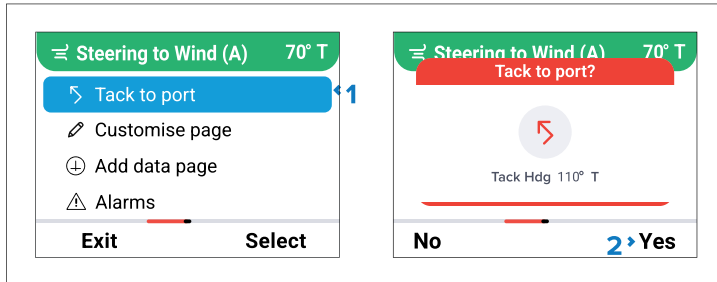

1. Select either *[Tack to port]*, or *[Tack to starboard]* from the main menu.
2. Press the *[Yes]* (Right soft) button to confirm the tack.

When you tack the vessel turns through the Tack angle. The autopilot will then adjust the heading to mirror the locked wind angle from the previous tack.

## Gybing

When sailing downwind, in *[Steer to Wind]* modes settings will be available to gybe your vessel. Gybing your vessel will turn the vessel to the same offset on the opposite side of the wind.

### Note:

Performing a Gybe will always be away from the wind. Gybes will be prevented if the autopilot's *[Gybe inhibit]* setting is set to *[Prevent Gybes]*.

Gybing is always relative to wind angle and is not adjustable.

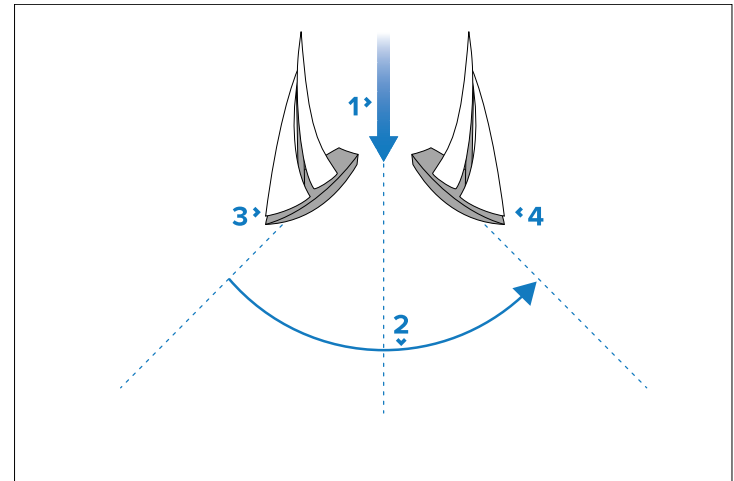

1. Wind direction.
2. Gybe.
3. Starting position.
4. Final position.

## Performing a gybe

The *[Gybe]* setting can be used to *[Gybe]* your vessel.

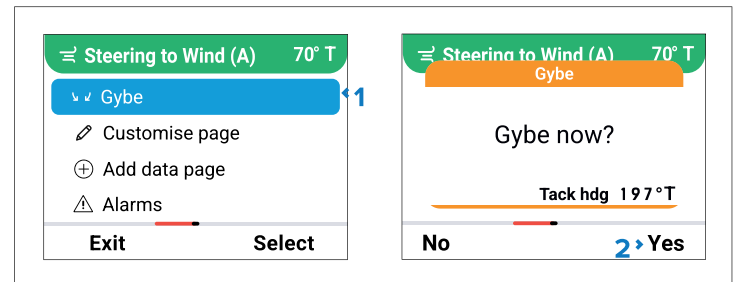

1. Select *[Gybe]* from the main menu.
2. Press the *[Yes]* (Right soft) button to confirm the gybe.

When you Gybe in a Steer to wind mode, the vessel turns through the Gybe angle. The autopilot will then adjust the heading to mirror the locked wind angle from the previous Gybe.

## 6.11 Power steer

[Power steer] mode enables you to directly control the rudder using the remote's [Left] and [Right] buttons.

While in [Power steer] mode the following options are available from the remote:

- Change autopilot mode — Press the [MODE] button to change the autopilot mode.
- Turn the rudder — Use the [Left] and [Right] buttons to adjust the rudder angle.
- Center the Rudder — Press the [Left Softkey] to [Re-centre] the rudder.
- Disengage the autopilot — Press the [STBY] (Standby) button to resume manual steering.

### Steering the vessel

In [Power steer] mode the remote can be used to command the rudder directly.

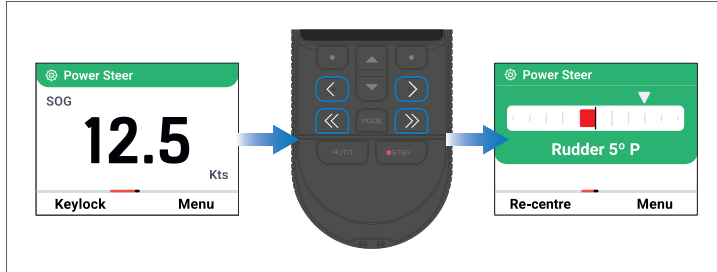

1. Use the adjustment buttons to change rudder angle:
  - [<] (Left 1°) — Each press will change the rudder angle by 1° to the left.
  - [<<] (Left 5°) — Each press will change the rudder angle by 5° to the left.
  - [>] (Right 1°) — Each press will change the rudder angle by 1° to the right.
  - [>>] (Right 5°) — Each press will change the rudder angle by 5° to the right.

# CHAPTER 7: DATA PAGES

## CHAPTER CONTENTS

- 7.1 Data pages — page 41
- 7.2 Creating a data page — page 41
- 7.3 Customizing a data page. — page 41
- 7.4 Deleting data pages — page 42
- 7.5 Data items — page 42

## 7.1 Data pages

Data pages are used to display supported data that is transmitted from connected devices and sensors.

### Example data page

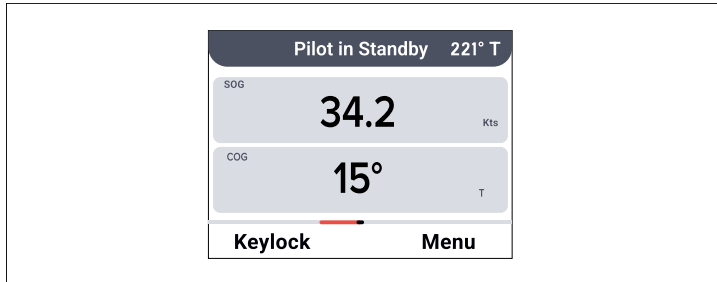

There are 6 of default data pages. The *[Up]* and *[Down]* buttons are used to cycle through the data pages.

These pages can be customized or deleted. When pages have been deleted new pages can be created.

The remote can have up to 6 data pages.

## 7.2 Creating a data page

### Note:

- The *[Add data page]* option is only available if the remote has less than 6 data pages.
- If *[Pilot control]* is enabled the autopilot must be in *[Standby]* for new data pages to be added.

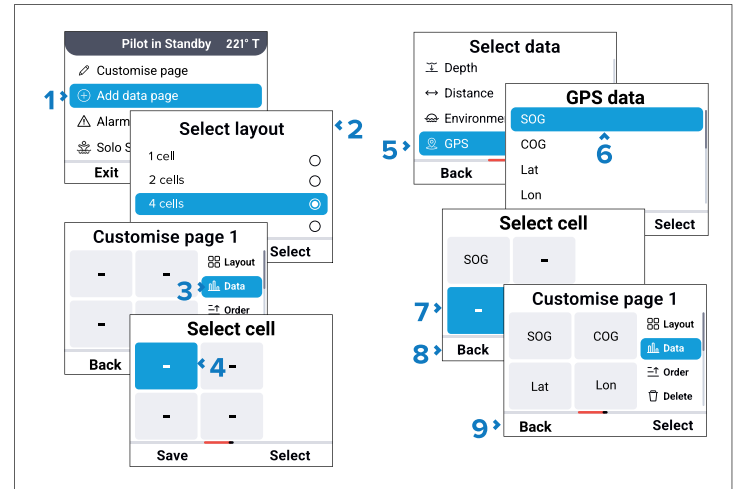

From the main menu:

1. Select *[Add data page]*.
2. Select a page layout.  
*Select 1 cell, 2 cells, or 4 cells as required. You can also add a [Navigation page].*
3. Select *[Data]*.
4. Select the cell you want to add data to.
5. Select the relevant data category.
6. Select the desired data item.
7. Repeat steps 5 to 7 for the remaining cells.
8. Select the *[Back]* (Left soft) button.
9. Select the *[Back]* (Left soft) button again to exit the page creation page.

## 7.3 Customizing a data page.

Existing data pages can be customized.

With the data page you want to customize displayed:

1. Press the *[Menu]* (Right soft) button.
2. Select *[Customize page]*.
3. From the Customize menu you can:
  - Select *[Layout]* to change the number of data cells on the page.

- Select *[Data]* to change the data item in each cell.
- Select *[Order]* to change the order that data pages appear.
- Select *[Delete]* to delete the current data page.

## 7.4 Deleting data pages



With the data page you want to delete displayed:





1. Press the *[Menu]* (Right soft) button.
2. Select *[Customize page]*.
3. Select *[Delete]*.
4. Select the *[Yes]* (Right soft) button.



If all data pages are deleted the remote's main screen will show the Raymarine logo.

## 7.5 Data items

The following data items can be added to data pages:

Data category	Data Items
 <i>[Depth]</i>	• <i>[Depth]</i>
 <i>[Distance]</i>	• <i>[Log]</i> • <i>[Trip]</i> • <i>[Distance to Waypoint]</i> • <i>[Cross Track Error]</i> • <i>[Distance to tack]</i> • <i>[Sailing distance to waypoint]</i>
 <i>[Environment]</i>	• <i>[Water Temperature]</i>

Data category	Data Items
 <i>[GPS]</i>	• <i>[Speed Over Ground]</i> • <i>[Course Over Ground]</i> • <i>[Latitude]</i> • <i>[Longitude]</i> • <i>[HDOP]</i> • <i>[Accuracy]</i> • <i>[Num of satellites]</i> • <i>[Vessel position]</i>
 <i>[Heading]</i>	• <i>[Heading]</i> • <i>[Locked heading]</i> • <i>[Course Over Ground]</i> • <i>[Opp tack heading]</i>
 <i>[Navigation]</i>	• <i>[Bearing To Waypoint]</i> • <i>[Distance to Waypoint]</i> • <i>[Cross Track Error]</i> • <i>[Waypoint name]</i> • <i>[Distance to tack]</i> • <i>[Next leg bearing]</i> • <i>[Sailing distance to waypoint]</i> • <i>[Time to destination]</i> • <i>[Time to waypoint]</i> • <i>[Waypoint Sailing TTG]</i> • <i>[VMG Waypoint]</i>
 <i>[Pilot]</i>	• <i>[Locked heading]</i>

	Data category	Data Items
	<i>[Speed]</i>	<ul style="list-style-type: none"> <li>• <i>[Speed (through water)]</i></li> <li>• <i>[Speed Over Ground]</i></li> <li>• <i>[Target speed]</i></li> <li>• <i>[Polar performance]</i></li> <li>• <i>[VMG Windward]</i></li> <li>• <i>[VMG to Waypoint]</i></li> </ul>
	<i>[Time]</i>	<ul style="list-style-type: none"> <li>• <i>[Time]</i></li> <li>• <i>[Date]</i></li> <li>• <i>[Time to destination]</i></li> <li>• <i>[Time to waypoint]</i></li> <li>• <i>[Waypoint Sailing TTG]</i></li> <li>• <i>[Countdown]</i></li> </ul>
	<i>[Wind]</i>	<ul style="list-style-type: none"> <li>• <i>[Apparent Wind Angle]</i></li> <li>• <i>[Apparent Wind Speed]</i></li> <li>• <i>[True Wind Angle]</i></li> <li>• <i>[True Wind Speed]</i></li> <li>• <i>[Target AWA]</i></li> <li>• <i>[Target TWA]</i></li> </ul>

# CHAPTER 8: ALARMS

## CHAPTER CONTENTS

- [8.1 Alarms — page 45](#)
- [8.2 Alarm settings — page 46](#)
- [8.3 Setting the countdown timer — page 46](#)

## 8.1 Alarms

When an alarm is triggered, an alarm notification is shown and an audible beep is sounded. The remote includes support for *[System alarms]* and *[Local alarms]*.

### Example alarm notification

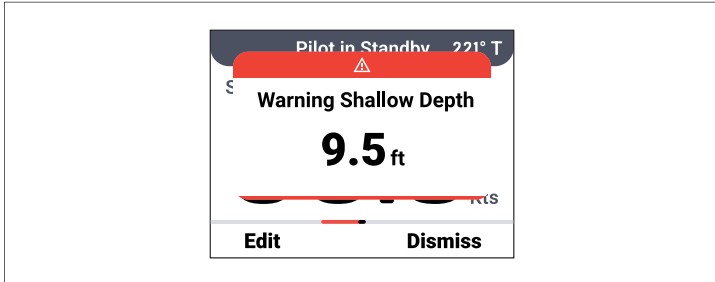

- Press the *[Dismiss]* (Right soft) button to dismiss the alarm.
- Press the *[Edit]* (Left soft) button to dismiss the alarm and open the Alarm settings to change the alarm's configuration.

### Instrument alarms

When an *[Instrument alarm]* is activated a notification will appear along with an audible beep on all compatible devices connected to the network.

Acknowledging a system alarm will dismiss/cancel the alarm on all devices.

Instrument alarms can be either:

- *[Configurable alarms]*— Configurable alarms can be enabled, disabled and a trigger threshold set from an instrument display.
- *[Fault alarms]*— A hardware or condition fault alarm, such as autopilot alarms are not usually configurable but may be able to be enabled and disabled on individual devices.

Please refer to the *Alarm settings* section of the device's *Operation instructions* to see which alarms are supported.

### Local alarms

A *[Local alarm]* is an alarm that is configured individually on each supported device. When a *[Local alarm]* is triggered it is only shown on that device.

Some *[Instrument alarms]* can be configured as a *[Local alarm]*. This allows you to configure a different trigger threshold than the threshold for the *[Instrument alarm]*.

If a *[Local alarm]* is changed to a *[Instrument alarm]* the *[Local]* threshold *[Value]* will be disabled.

Please refer to the *Alarm settings* section of the device's *Operation instructions* to see which alarms are supported.

### Configuring an alarm example

As an example the *[Shallow depth]* alarm can be configured as a *[Instrument alarm]*, or a *[Local alarm]*.

Follow the steps below to configure the *[Shallow depth]* alarm as a *[Local alarm]*.

1. Select *[Alarms]* from the *[Settings]* menu.
2. Scroll down to *[Shallow depth]*.
3. Select *[Local alarm]*.
4. Select *[Value]*.
5. Use the *[Up]* and *[Down]* buttons to set a trigger threshold.
6. Select *[Save]*.

The *[Shallow depth]* alarm will now trigger on the remote when your vessel's depth reading reaches the specified *[Value]*.

#### Note:

This will not impact a system *[Shallow depth]* alarm from triggering on other devices when the system trigger threshold is reached.

Selecting *[Instrument alarm]* will disable the *[Local alarm]*. Selecting *[None]* will disable both the *[Instrument alarm]* and *[Local alarm]* on the remote.

## 8.2 Alarm settings

Supported alarms are configured from the *[Alarms]* menu.

Alarm	Description\Options	Behavior
<i>[Lost connection MOB]</i>	Toggle switch	System (When enabled)
<i>[Countdown]</i>	When the countdown not active the following options are available: <ul style="list-style-type: none"> <li><i>[Start value]</i></li> <li><i>[Start countdown]</i></li> </ul> With the countdown active the following options are available: <ul style="list-style-type: none"> <li><i>[Stop countdown]</i></li> <li><i>[Pause countdown]</i></li> </ul> With the countdown paused the following options are available: <ul style="list-style-type: none"> <li><i>[Restart countdown]</i></li> <li><i>[Reset]</i></li> </ul>	Local only
<sup>(1)</sup> <i>[Shallow depth]</i>	<ul style="list-style-type: none"> <li><i>[Instrument alarm]</i></li> <li><i>[Local alarm]</i></li> <li><i>[Value]</i></li> <li><i>[None]</i></li> </ul>	Instrument, or local
<i>[High wind speed]</i>	<ul style="list-style-type: none"> <li><i>[Value]</i></li> <li><i>[Alarm]</i></li> </ul>	Local only
<i>[Low wind speed]</i>	<ul style="list-style-type: none"> <li><i>[Value]</i></li> <li><i>[Alarm]</i></li> </ul>	Local only
<i>[Pilot alarms]</i>	<ul style="list-style-type: none"> <li><i>[Notifications]</i></li> </ul>	System (When enabled)

Alarm	Description\Options	Behavior
<i>[Waypoint arrival]</i>	<ul style="list-style-type: none"> <li><i>[Notifications]</i></li> </ul>	System (When enabled)
<i>[Lost GNSS fix]</i>	<ul style="list-style-type: none"> <li><i>[Notifications]</i></li> </ul>	System (When enabled)

### Note:

<sup>(1)</sup>When the *[Shallow depth]* alarm is set to *[System]* the remote control will share this alarm with compatible SeaTalk NG Instruments. The alarm is NOT shared with chartplotters.

## 8.3 Setting the countdown timer

The countdown timer is located in the *[Alarms]* menu.

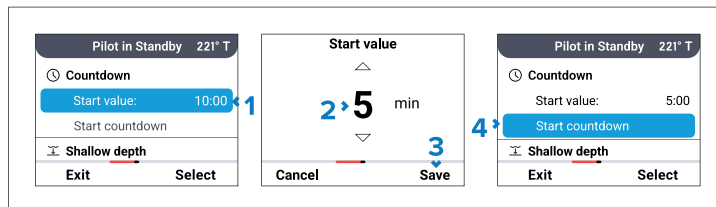

From the *[Alarms]* menu:

1. Select *[Start value]*.
2. Use the *[Up]* and *[Down]* buttons to adjust the *[Start value]*.
3. Select *[Save]*.
4. Select *[Start countdown]*.

The countdown timer page will be displayed.

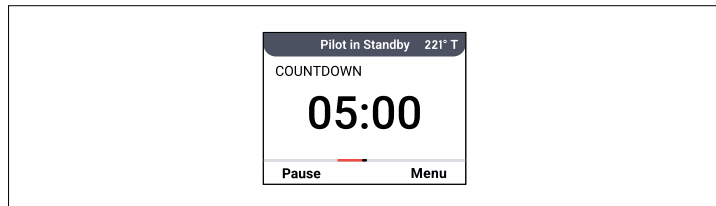

While the countdown timer is running:

- An audible tone will sound from 5 minutes at each whole minute.
- An audible tone will sound from 10 seconds for each whole minute.
- When the timer reaches zero an alarm will sound and a notification is displayed.

You can *[Pause]* and *[Resume]* the countdown using the Left soft button

# CHAPTER 9: POINT AND GO AND WAYPOINTS

## CHAPTER CONTENTS

- 9.1 Waypoints — page 49
- 9.2 Point and Go — page 49
- 9.3 Performing a Point and Go — page 49

## 9.1 Waypoints

When the remote is connected to a system that includes a chartplotter waypoints can be placed at your vessel's current location using the remote.

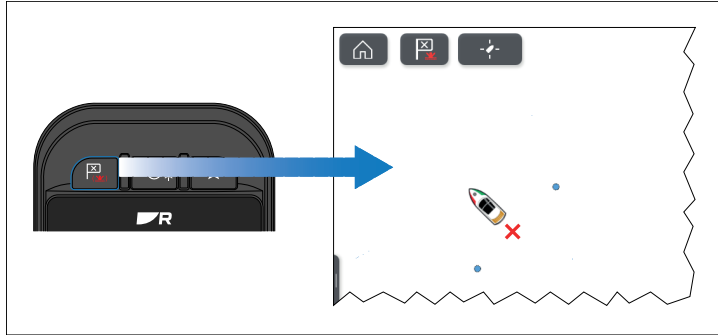

Press the *[Waypoint / MOB]* button to place a waypoint.  
You can view the waypoint from your chartplotter.

## 9.2 Point and Go

A *[Point and Go]* can be initiated from the remote using the *[Point and Go]* button.

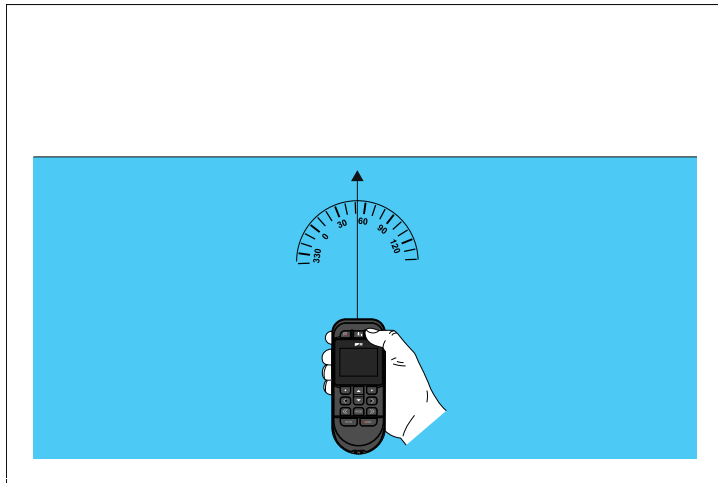

Point and Go and waypoints

When the *[Point and Go]* button is pressed the bearing at which the remote is pointing will be used, in conjunction with a user defined *[Range]* to initiate active navigation and engage the autopilot in *[Steer to Navigation]* mode.

The *[Point and Go]* feature requires a compatible chartplotter to be connected to the system.

### Note:

The *[Point and Go]* feature requires the remote's internal sensors to be calibrated. If calibration has not been carried out you will be requested to do so when the *[Point and Go]* button is first pressed. For details on calibrating the compass refer to: [p.27 – Calibrating the internal sensors](#)

## 9.3 Performing a Point and Go

Holding the remote horizontally, pointing in the direction you wish to travel to:

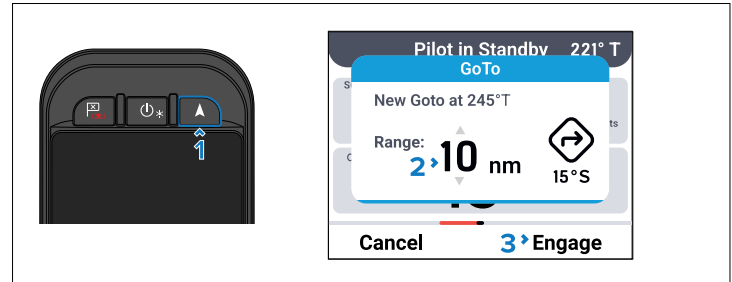

1. Press the *[Point and Go]* button.
2. Use the *[Up]* and *[Down]* buttons adjust the range for the *[Point and Go]*.
3. Press the *[Engage]* (Right soft) button.

Active navigation will commence on the chartplotter and the autopilot will engage in *[Steer to Navigation]* mode.

# CHAPTER 10: SOLO SAILOR AND MAN OVERBOARD

## CHAPTER CONTENTS

- 10.1 Solo sailor — page 51
- 10.2 Man overboard — page 51
- 10.3 Lost connection MOB — page 52

## 10.1 Solo sailor

[Solo sailor] is a safety mode intended to be used when a single person is sailing a boat. When [Solo sailor] is enabled and the autopilot is in a steer to wind mode, if connection to the remote is lost the system assumes that the sailor has fallen overboard and automatically turns the boat directly into the wind to slow down and stop the boat.

### Note:

- [Solo sailor] is only available when your autopilot is configured as a sailing [Boat type] / [Vessel hull type]. Refer to the commissioning instructions for your autopilot for details on how to configure the [Boat type] / [Vessel hull type].
- If the autopilot is not in [Steer to Wind] mode the Man Overboard alarm will be triggered but the autopilot will take no action.

### Important:

Do NOT use [Solo sailor] mode when there is crew aboard.

### Solo sailor sequence

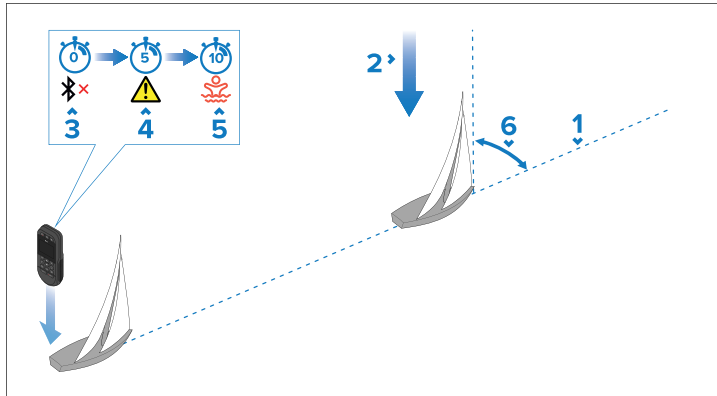

1. Vessel's current locked wind angle.
2. Wind direction.
3. Bluetooth connection to the remote is lost.

4. 5 seconds after connection is lost a warning is displayed.
5. 10 seconds after connection is lost a Man Overboard alarm is triggered.
6. At 10 seconds the autopilot will automatically turn the vessel into the wind.

If the remote re-connects at any point up to the Man Overboard alarm being triggered the process is cancelled.

When the remote is switched on if [Solo sailor] was previously enabled a warning is displayed. [Solo sailor] can be disabled from the warning.

## 10.2 Man overboard

If a person or object falls overboard, you can use the Man Overboard (MOB) alarm to mark the position that your vessel was at when the alarm was activated.

The MOB alarm is a system alarm that can be activated using the remote's [Waypoint / MOB] button, or from a connected chartplotter.

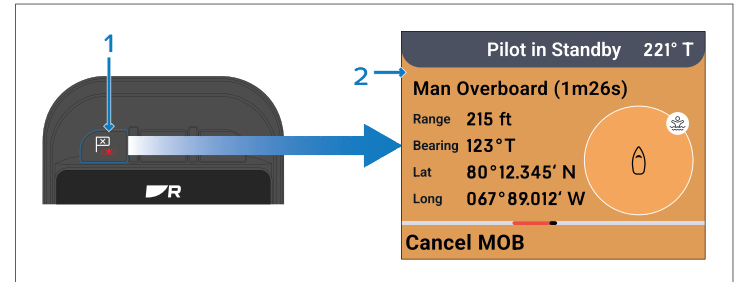

1. Press and hold the [Waypoint / MOB] button for 2 seconds to activate the MOB alarm. The remote must be connected to the system to activate the MOB alarm.
2. The MOB page is displayed on the remote to help you navigate back to the position your vessel was at when the alarm was activated.

### Cancelling a MOB alarm

An active MOB alarm can be cancelled from the remote, or from a connected chartplotter.

From the remote you can press and hold the [Waypoint / MOB] button (1) for 2 seconds, or press the [Cancel MOB] (Left soft) button (2).

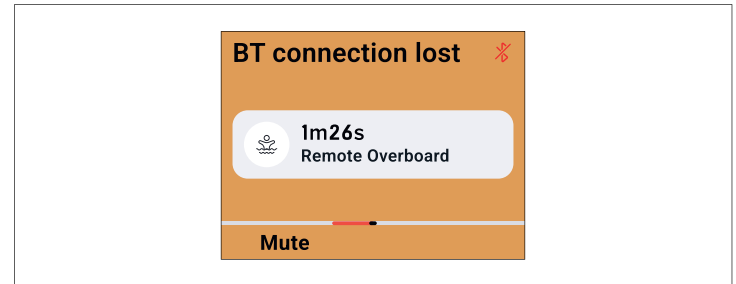
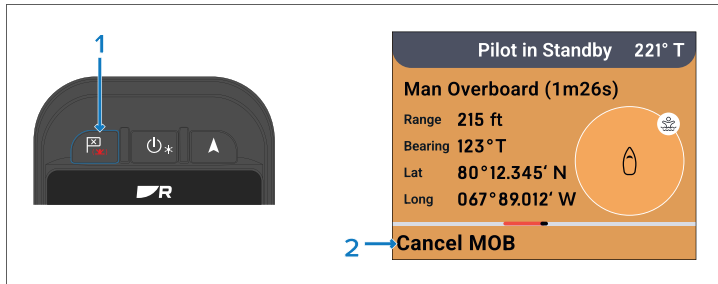

## 10.3 Lost connection MOB

The *[Lost connection MOB]* alarm is a safety alarm intended to alert the crew that the person using the remote has fallen overboard. When connection to the remote is lost the system assumes that the crew member using the remote has fallen overboard.

When *[Lost connection MOB]* is enabled, if the connection between the remote and the system is lost the alarm is activated.

### Lost connection MOB sequence

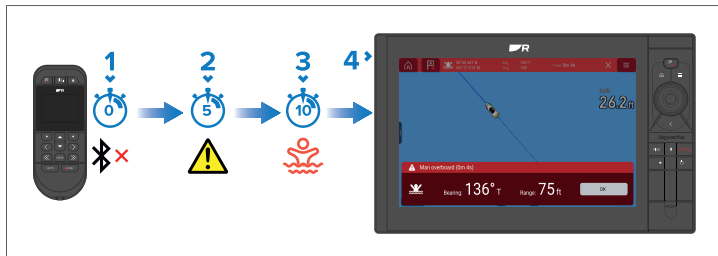

1. Bluetooth connection to the remote is lost.
2. 5 seconds after connection is lost a warning is displayed.
3. 10 seconds after connection is lost the *[Lost connection MOB]* alarm is triggered.
4. At 10 seconds the MOB alarm is triggered on connected chartplotters.

If the remote re-connects at any point up to the Man Overboard alarm being triggered the process is cancelled.

While the Lost connection MOB alarm is active the Lost connection MOB page is displayed on the remote.

### Cancelling the Lost connection MOB alarm

The *[Lost connection MOB]* alarm must be cancelled on the remote and chartplotter separately.

- From the remote, press the *[Mute]* (Left soft) button.
- Cancel the MOB alarm from the chartplotter in the normal way.

The alarm does not cancel automatically if connection is re-established.









# CHAPTER 11: SETTINGS





## CHAPTER CONTENTS

- [11.1 Main menu — page 54](#)
- [11.2 Pilot settings menu — page 55](#)
- [11.3 Settings menu — page 55](#)

## 11.1 Main menu

All settings are accessed from the main menu.





Setting	Description
 <i>[Lock keypad]</i>	Locks the remotes buttons. This setting is not shown if <i>[Lock keypad]</i> has been configured as the shortcut.
 <i>[Cancel countdown]</i>	Cancels a running countdown. This setting is only shown if the countdown is running.
 <i>[Advance waypoint]</i>	Advances navigation to the next waypoint in a route. This setting is only shown in <i>[Steer to Navigation]</i> mode. This setting is not shown if it has been configured as a shortcut.
 <i>[Restart XTE]</i>	Restart you current track at your vessel's current position. This setting is only shown in <i>[Steer to Navigation]</i> mode.
 <i>[Tack to port]</i>	Perform a <i>[Tack to port]</i> side. This setting is only available in <i>Steer to Wind</i> modes when heading upwind.
 <i>[Tack to starboard]</i>	Perform a <i>[Tack to starboard]</i> side. This setting is only available in <i>Steer to Wind</i> modes when heading upwind.
 <i>[Gybe]</i>	Perform a Gybe. This setting is only available in <i>Steer to Wind</i> modes when heading downwind. This setting will not be shown if the <i>[Gybe inhibit]</i> setting in your chartplotter is set to <i>[Prevent Gybe]</i> .
 <i>[Customize page]</i>	Select to customize the data page you were on when you opened the menu. For information about customizing data pages refer to: <a href="#">p.41 — Customizing a data page.</a>





Setting	Description
 <i>[Add data page]</i>	Select to create a new data page. The setting will not be available if the remote already has 10 data pages. For information about adding data pages refer to: <a href="#">p.41 — Creating a data page</a>
 <i>[Alarms]</i>	Open the <i>[Alarms]</i> settings to configure alarms. For information about available <i>[Alarms]</i> refer to: <a href="#">p.44 — Alarms</a>
 <i>[Solo sailor]</i>	Enable and disable <i>[Solo sailor]</i> . For information about <i>[Solo sailor]</i> refer to: <a href="#">p.51 — Solo sailor</a>
 <i>[Pilot settings]</i>	Open the <i>[Pilot settings]</i> menu. For <i>[Pilot settings]</i> refer to: <a href="#">p.55 — Pilot settings menu</a>
 <i>[Settings]</i>	Open the <i>[Settings]</i> menu. For <i>[Settings]</i> refer to: <a href="#">p.55 — Settings menu</a>

## 11.2 Pilot settings menu

Setting	Description
 <i>[Pilot control]</i>	Select to enable or disable autopilot control.
<i>[Responsiveness]</i>	Determine the responsiveness of the autopilot. The available options are: <ul style="list-style-type: none"> <li>• <i>[Leisure]</i> — Suitable for long passages where tight heading control is not critical.</li> <li>• <i>[Cruise]</i> — Good course-keeping without overworking pilot.</li> <li>• <i>[Performance]</i> — Emphasis on tight heading control.</li> </ul>
<i>[Power steer]</i>	Enables and disables <i>[Power steer]</i> mode for the <i>[Power]</i> <i>[Boat type]</i> / <i>[Vessel hull type]</i> . <ul style="list-style-type: none"> <li>• <i>[OFF]</i></li> <li>• <i>[ON]</i></li> </ul>

## 11.3 Settings menu

Setting	Description
<i>[Demo mode]</i>	Enable and disable <i>[Demo mode]</i> . In <i>[Demo mode]</i> the remote will display simulated data. <i>[Demo mode]</i> cannot be enabled while the autopilot is engaged. <div data-bbox="1199 340 1560 467" style="border: 1px solid black; padding: 5px; margin-top: 10px;"> <p><b>Note:</b> The remote will not be able to control the autopilot while <i>[Demo mode]</i> is enabled.</p> </div>
 <i>[Key beep]</i>	By default, every time a button is pressed, the remote emits an audible beep. The beep can be enabled or disabled using the <i>[Key beep]</i> option.
 <i>[Calibrate compass]</i>	Calibrate the remote's internal sensors. Calibration requires you to move the remote in figure of 8 pattern until complete. For further details refer to: <a href="#">p.27 — Calibrating the internal sensors</a>
 <i>[Shortcut key]</i>	Select which setting is assigned to the <i>[Left soft]</i> button. For a list of available shortcuts, refer to: <a href="#">p.56 — Shortcut button options</a>
 <i>[Language]</i>	Change the user interface language. For a list of available languages, refer to: <a href="#">p.24 — User interface languages</a>
 <i>[Data responsiveness]</i>	<i>[Data responsiveness]</i> allows you to specify how quickly the displayed data is refreshed when the received data changes. For further details refer to: <a href="#">p.27 — Setting data responsiveness</a>

Setting	Description
 <i>[Performance]</i>	Choose time-outs for the <i>[Backlight]</i> , <i>[Sleep]</i> and auto <i>[Power off]</i> . For further details refer to: <a href="#">p.27 – Setting the remote performance</a>
 <i>[Unpair Bluetooth connection]</i>	Select to unpair the remote from the wireless gateway.
 <i>[Reset device]</i>	Reset the remote to its default settings.
 <i>[About this device]</i>	Provides hardware and software details for the remote. Scrolling down will reveal the Bluetooth connection details and the type of batteries in use. Pressing the <i>[Self-test]</i> (Right soft) button will initiate a self test of the remote.
 <i>[Legal]</i>	Displays the <i>Terms</i> of use disclaimer

## Shortcut button options

You can select which option is assigned to the *[Left soft]* button.

The available options are:

- *[None]*
- *[Lock keypad]*
- *[Steer to Nav]*
- *[Steer to Wind]*
- *[Advance Waypoint]*
- *[Reset XTE]*
- *[Tack]*

# CHAPTER 12: TROUBLESHOOTING

## CHAPTER CONTENTS

- 12.1 Troubleshooting — page 58
- 12.2 Connection troubleshooting — page 58
- 12.3 WG-1 LED diagnostics — page 59

## 12.1 Troubleshooting

The troubleshooting section provides possible causes and the corrective action required for common problems that are associated with the installation and operation of your product.

Before packing and shipping, all products are subjected to comprehensive testing and quality assurance programs. If you do experience problems with your product, this section will help you to diagnose and correct problems to restore normal operation.

If after referring to this section you are still having problems with your product, please refer to the *Technical support and servicing* section of this manual for useful links and contact details.

## 12.2 Connection troubleshooting

### Notification



### Could not connect

The WG-1 wireless gateway cannot be found. Press the *[Retry]* button. If the connection fails again try the following:

1. Check that the gateway is powered on and in range of the remote.
2. Check the gateway's LED to see if there is an issue with the gateway.
3. Power cycle the gateway.

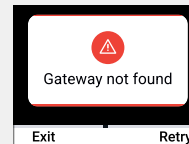

### Gateway not found

The remote connection timed out. Press the *[Retry]* button. If the connection fails again try the following:

1. Check that the gateway is powered on and in range of the remote.
2. Check the gateway's LED to see if there is an issue with the gateway.
3. Power cycle the gateway.

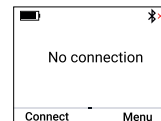

### No connection



Connection was cancelled by the user.

1. Press the *[Connect]* (Left soft) button to establish a connection with the gateway.

## 12.3 WG-1 LED diagnostics

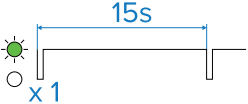
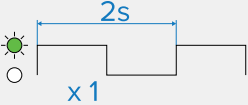
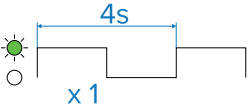
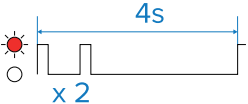
The wireless gateway has diagnostic LEDs on the front of the unit. These LEDs are used to identify the unit's status, and can be used for troubleshooting.

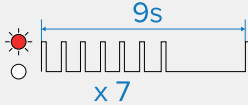
LED indication	LED status and possible solutions
	<p>(Green) Powered up / Ok</p> <ul style="list-style-type: none"> <li>Normal operation — no user action is required.</li> </ul>
	<p>(Green) No wind vane connected / Wind vane connecting</p> <ul style="list-style-type: none"> <li>Check the relevant product, network cabling and connections for signs of damage or corrosion, and replace if necessary.</li> </ul>
	<p>(Green) Update in progress</p> <ul style="list-style-type: none"> <li>Normal operation — no user action is required.</li> </ul>
	<p>(Red) CAN not connected</p> <ul style="list-style-type: none"> <li>Check the relevant product, network cabling and connections for signs of damage or corrosion, and replace if necessary.</li> <li>Consider contacting your local dealer or Raymarine® Product Support.</li> </ul>

LED indication	LED status and possible solutions
	<p>(Red) CAN Fault</p> <ul style="list-style-type: none"> <li>Check the relevant product, network cabling and connections for signs of damage or corrosion, and replace if necessary.</li> <li>Consider contacting your local dealer or Raymarine® Product Support.</li> </ul>
	<p>(No color) No power</p> <ol style="list-style-type: none"> <li>Check the vessel's battery voltage, the condition of the battery terminals and power supply cables, ensuring connections are secure, clean and free from corrosion; replace if necessary.</li> <li>Check the power supply cable and connectors for signs of damage or corrosion; replace if necessary.</li> <li>Check that the power cable connector is fully inserted into the unit and locked in position.</li> <li>With the unit turned on, try flexing the power cable near to the connector to see if this causes the unit to re-start/lose power; replace if necessary.</li> <li>With the product under load, using a multi-meter, check for high voltage drop across all connectors / fuses etc, and replace if necessary.</li> </ol>

## LED diagnostic guidance

Your product has diagnostic LEDs which can be used to identify the unit's status and to help troubleshoot any potential issues that may occur.

The following section provides two basic examples of how to interpret the LED diagnostic patterns included in this publication.

### Example solid LED diagnostic pattern:

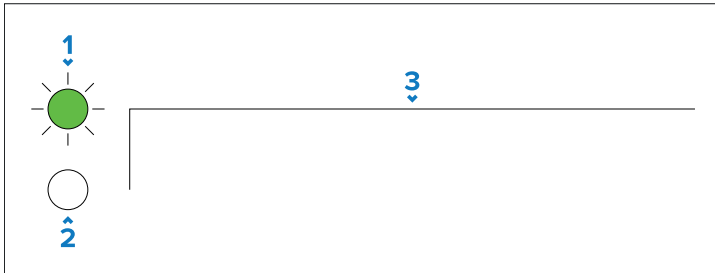

1. **LED ON** — Indicates the color assigned to the unit's diagnostic LED, and confirms that the diagnostic LED is active (switched **on**).
2. **LED OFF** — Indicates that the unit's diagnostic LED is inactive (switched **off**).
3. **Diagnostic pattern** — Indicates a diagnostic pattern based on the number and duration of *peaks* (indicating LED is switched **on**) and *troughs* (indicating LED is switched **off**) generated within the duration of the diagnostic pattern. In the example shown above, a continuous peak occurs, indicating that the LED is permanently **on**.

### Example flashing LED diagnostic pattern:

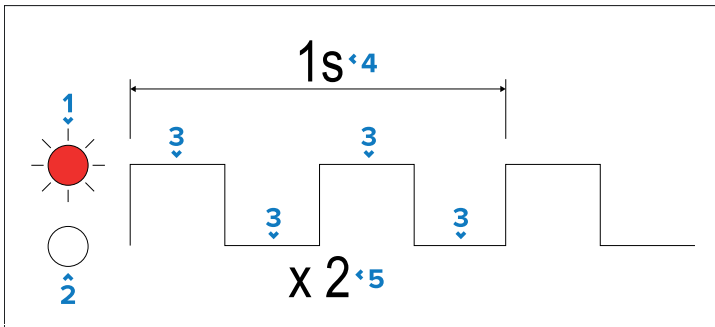

1. **LED ON** — Indicates the color assigned to the unit's diagnostic LED, and confirms that the diagnostic LED is active (switched **on**).
2. **LED OFF** — Indicates that the unit's diagnostic LED is inactive (switched **off**).
3. **Diagnostic pattern** — Indicates a diagnostic pattern based on the number and duration of *peaks* (indicating LED is switched **on**) and *troughs* (indicating LED is switched **off**) generated within the duration of the diagnostic pattern. In the example shown above, a peak followed by a trough occurs and then repeats again, indicating that the LED flashes twice within a period of one second.
4. **Diagnostic pattern duration** — Indicates the total duration of the diagnostic pattern.
5. **Diagnostic pattern flash total** — Indicates the total number of flashes that occur within the diagnostic pattern.

# CHAPTER 13: MAINTENANCE

## CHAPTER CONTENTS

- 13.1 Routine equipment checks — page 62
- 13.2 Replacing the batteries — page 62
- 13.3 Product cleaning — page 62

## 13.1 Routine equipment checks

It is recommended that you perform the following routine checks, on a regular basis, to ensure the correct and reliable operation of your equipment:

- Examine all cables for signs of damage or wear and tear.
- Check that all cables are securely connected.

### Caution: Service and maintenance

This product contains no user serviceable components. Please refer all maintenance and repair to authorized Raymarine dealers. Unauthorized repair may affect your warranty.

## 13.2 Replacing the batteries

The AA batteries can be replaced by removing the rear battery cover.

### Note:

Only use AA batteries to power the remote.

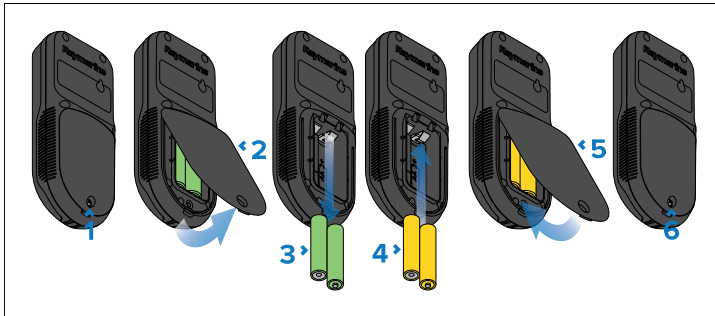

1. Unscrew the captive battery cover screw.
2. Remove the battery cover by pivoting the bottom away from the remote control.
3. Remove the batteries.
4. Ensuring correct orientation, insert the new batteries.

*Battery orientation is indicated in the battery compartment and is viewable when no batteries are present.*

5. Replace the battery cover by inserting the top lugs into the remote control at a slight angle, and then push the bottom of the cover until it is fully inserted.
6. Re-tighten the battery cover screw.

## 13.3 Product cleaning

Best cleaning practices.

When cleaning products:

- Switch off power supply.
- Use a clean damp cloth to wipe clean.
- Do NOT use: abrasive, acidic, ammonia, solvent or other chemical-based cleaning products.
- Do NOT use a jet wash.

### Cleaning the display case

The display is a sealed unit and does not require regular cleaning. If it is necessary to clean the display, follow this basic procedure:

1. Switch off the power to the display.
2. Wipe the case with a clean, lint-free cloth.
3. If necessary, use a mild detergent to remove grease marks.

### Cleaning the display screen

A coating is applied to the display screen. This makes it water repellent, and prevents glare. To avoid damaging this coating, follow this procedure:

1. Switch off the power to the display.
2. Rinse the screen with fresh water to remove all dirt particles and salt deposits.
3. Allow the screen to dry naturally.
4. If any smears remain, very gently wipe the screen with a clean microfibre cleaning cloth.

# CHAPTER 14: TECHNICAL SUPPORT

## CHAPTER CONTENTS

- 14.1 Raymarine technical support and servicing — page 64
- 14.2 Viewing product information — page 65
- 14.3 Viewing product information from a chartplotter — page 65
- 14.4 Learning resources — page 66

## 14.1 Raymarine technical support and servicing

Raymarine provides a comprehensive product support service, as well as warranty, service, and repairs. You can access these services through the Raymarine website, telephone, and e-mail.

### Product information

If you need to request service or support, please have the following information to hand:

- Product name.
- Product identity.
- Serial number.
- Software application version.
- System diagrams.

### Servicing and warranty

Raymarine offers dedicated service departments for warranty, service, and repairs.

Visit the Raymarine website to **read the latest warranty policy**, and **register** your product's warranty online:

- [www.bit.ly/rym-warranty](http://www.bit.ly/rym-warranty)

#### United Kingdom (UK), EMEA, and Asia Pacific:

- Web: [www.bit.ly/rym-service](http://www.bit.ly/rym-service)
- Tel: +44 (0)1329 246 932

#### United States (US):

- Web: [www.bit.ly/rym-service](http://www.bit.ly/rym-service)
- Tel: +1 (603) 324 7900

### Web support

Please visit the “Support” area of the Raymarine website for:

- **Manuals and Documents** — [www.bit.ly/rym-docs](http://www.bit.ly/rym-docs)
- **Technical support forum** — [www.bit.ly/rym-support](http://www.bit.ly/rym-support)
- **Software updates** — [www.bit.ly/rym-software](http://www.bit.ly/rym-software)

### Telephone and online support

Region	Contact details
<b>All regions</b>	<b>Online support:</b> <a href="http://www.bit.ly/rym-support">www.bit.ly/rym-support</a>
<b>United Kingdom (UK) and EMEA</b>	<b>Telephone:</b> +44 (0)1329 246 777 <b>Address:</b> Marine House, Cartwright Drive, Fareham, PO15 5RJ, UK.
<b>United States (US)</b>	<b>Telephone:</b> Tel: +1 (603) 324 7900 (Toll-free: +800 539 5539) <b>Address:</b> 110 Lowell Road, Hudson, NH 03051, USA.
<b>Australia and New Zealand</b> (Raymarine subsidiary)	<b>Telephone:</b> +61 2 8977 0300 <b>Address:</b> Suite 1.01, 26 Rodborough Road, Frenchs Forest, NSW, 2086, Australia.
<b>France</b> (Raymarine subsidiary)	<b>Telephone:</b> +33 (0)1 46 49 72 30 <b>Address:</b> 35 avenue Michel Crépeau, 17000 La Rochelle - France.
<b>Germany</b> (Raymarine subsidiary)	<b>Telephone:</b> +49 40 237 808 0 <b>Address:</b> Atlantic-Haus, Zirkusweg 1, 20359 Hamburg.
<b>Italy</b> (Raymarine subsidiary)	<b>Telephone:</b> +39 02 9945 1001 <b>Address:</b> Via L. Manara 2, 20812 Limbiate (MB), Italy.
<b>Spain</b> (Authorized Raymarine distributor)	<b>Telephone:</b> +34 96 2965 102 <b>Email:</b> <a href="mailto:sat@azimut.es">sat@azimut.es</a>
<b>Netherlands / Benelux</b> (Authorized Raymarine distributor)	<b>Telephone:</b> +31 (0)26 3614 905 <b>Address:</b> Florijnweg 21G, 6883 JN VELD, Nederland.

Region	Contact details
<b>Sweden</b> (Raymarine subsidiary)	<b>Telephone:</b> +46 (0)317 633 670 <b>Address:</b> Bolshedens Industriväg 18, 427 50 Billdal, Sweden.
<b>Finland</b> (Raymarine subsidiary)	<b>Telephone:</b> +358 (0)207 619 937 <b>Address:</b> Suomalaistentie 1-3, 02270 Espoo, Finland.
<b>Norway</b> (Raymarine subsidiary)	<b>Telephone:</b> +47 692 64 600 <b>Address:</b> Årvollskogen 30, 1529 Moss, Norway.
<b>Denmark</b> (Raymarine subsidiary)	<b>Telephone:</b> +45 437 164 64 <b>Address:</b> Centervej 7, 4600 Køge, Denmark.
<b>Russia</b> (Distributor)	<b>Telephone:</b> Tel: +7 495 788 0508 <b>Email:</b> <a href="mailto:info@mikstmarine.ru">info@mikstmarine.ru</a>

## 14.2 Viewing product information

Use the *[About this device option]* in the *[Settings]* menu to view hardware and software information about your product.

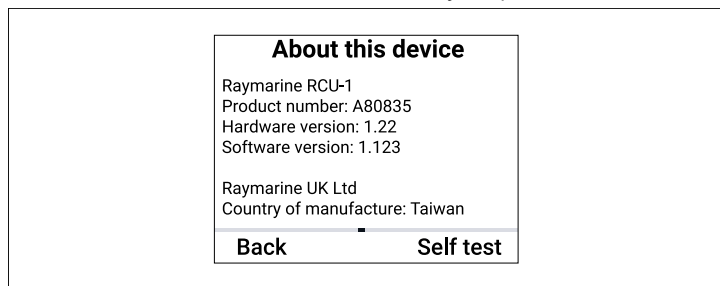

1. Press the *[Menu]* button.
2. Scroll to the *[Settings]* menu and press the *[Select]* button.
3. Scroll to the *[About this device]* menu and press the *[Select]* button.
4. Scroll down to view further details.

## 14.3 Viewing product information from a chartplotter

Hardware and software information related to your product can be viewed from a compatible chartplotter running LightHouse 4.

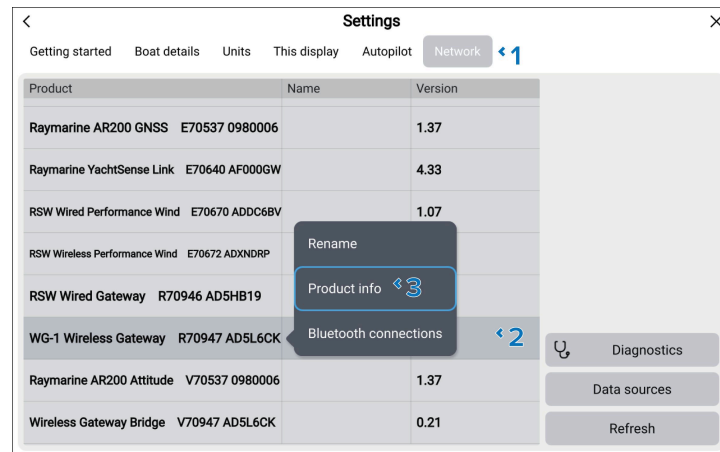

From the *[Homescreen > Settings]* menu:

1. Select the *[Network]* tab.
2. Select your device from the network list.  
*The software version for your device will be listed in the [Version] column of the network list.*
3. Select *[Product info]* from the pop-over options.

The product information details for the selected device will be displayed.

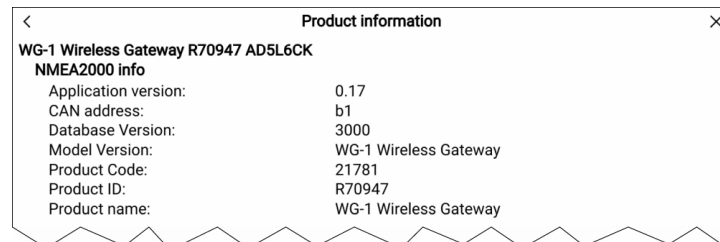

## 14.4 Learning resources

Raymarine has produced a range of learning resources to help you get the most out of your products.

### Video tutorials

*Raymarine official channel on YouTube*

- <http://www.youtube.com/user/RaymarineInc>

### Training courses

Raymarine regularly runs a range of in-depth training courses to help you make the most of your products. Visit the Training section of the Raymarine website for more information:

- [www.bit.ly/rym-training](http://www.bit.ly/rym-training)

### Technical support forum

You can use the Technical support forum to ask a technical question about a Raymarine product or to find out how other customers are using their Raymarine equipment. The resource is regularly updated with contributions from Raymarine customers and staff:

- [www.bit.ly/rym-support](http://www.bit.ly/rym-support)

## Appendix A NMEA 2000 PGN support

Supported standard NMEA 2000 PGNs are listed below. Proprietary PGNs are not listed.

**Note:**

Support for some PGNs may be restricted to a specific application.

### Administration PGNs

- **59392** — ISO Acknowledge (Transmit)
- **59904** — ISO Request (Receive / Transmit)
- **60160** — ISO Transport Protocol, Data Transfer (Receive)
- **60416** — ISO Transport Protocol, Connection Management — BAM Group Function (Receive)
- **60928** — ISO Address Claim (Receive / Transmit)
- **65240** — ISO Commanded address (Receive)
- **126208** — NMEA — Request, Commanded, Acknowledged Group Function (Receive / Transmit)
- **126464** — PGN Transmit and Receive List (Transmit)
- **126993** — Heartbeat (Receive / Transmit)
- **126996** — Product Information (Transmit)
- **126998** — Configuration Information (Transmit)



# Index

## A

Advance waypoint .....	34
Alarms .....	45–46
Countdown .....	46
Example .....	45
Instrument alarms .....	45
Local alarms .....	45
Lost connection MOB .....	52
Applicable documents .....	13
AUTO .....	29
Automatic turning .....	34
Autopilot	
Engaging .....	29–30
Status bar .....	25
Steer to Navigation .....	30
Steer to Wind .....	30
Autopilot modes	
Supported .....	29
Unsupported .....	29
Autopilot systems	
Compatible .....	16, 19
Evolution .....	16, 19

## B

Batteries	
Inserting .....	22
Replacement .....	62
Battery disposal .....	10
Battery power level .....	26
Battery saving .....	27
Bluetooth	
Pairing .....	24
Signal strength .....	26
Brightness .....	25–26
Brightness level .....	26
Brightness menu .....	26
Buttons .....	23

## C

Calibration .....	27
Chartplotter compatibility .....	19
Cleaning .....	62
Screen .....	62
Controls .....	23
Countdown .....	46
Countdown timer .....	46
Cradle	
Inserting .....	22
Removing .....	22
Cross track error .....	33

## D

Data items .....	42
Data pages .....	41
Creation .....	41
Customizing .....	41
Data items .....	42
Deletion .....	42
Navigation page .....	32
Data responsiveness .....	27
Diagnostics .....	60, 65
Disengaging autopilot .....	29
Document information	
Latest documentation .....	13
Documentation .....	13

## E

Engaging autopilot .....	29, 31
--------------------------	--------

## G

Gybe .....	38
------------	----

## K

Keylock .....	26
---------------	----

## L

Languages .....	24
Latest documentation .....	13
LED diagnostics (WG-1) .....	59
Locked heading .....	29
Locked Heading .....	29
Lost connection MOB Cancelling .....	52

## M

Maintenance .....	9, 62
Man overboard Lost connection MOB .....	52
Man Overboard (MOB) Activating .....	51
Cancelling .....	51

## N

Navigation page .....	32
Night mode .....	26
NMEA 2000 .....	67

## P

Performance .....	27
PGNs .....	67
Point and Go .....	49
Power off .....	24
Power on .....	24
Power steer .....	31, 39
Steering .....	39
Product documentation .....	13
Product information .....	65
Product overview .....	16
Product recycling (WEEE) .....	10
Product support .....	64

## R

Route complete .....	33
Routine checks .....	62
Rudder Indicator bar .....	25

## S

Sailing Steer to wind .....	35
Wind vane mode .....	35
Service Center .....	64
Servicing .....	9, 62
Settings Main menu .....	54
Pilot settings .....	55
Settings menu .....	55
Shortcut button .....	56
Software Updates .....	20
Software updates .....	19–20
Software version .....	19
STBY .....	29
Steer to heading .....	31
Steer to Heading Change locked heading .....	31
Steer to navigation .....	32
Steer to Navigation Advance waypoint .....	34
Automatic turning .....	34
Override .....	32
Route complete .....	33
Waypoint arrival .....	33
Steer to Polar .....	31
Performance .....	36
Steer to wind .....	35, 37
Fixed angles .....	35
Mirrored TWA .....	35
Polar .....	36
Steer to Wind Change wind angle .....	37
Steer to Wind (A) .....	31

Steer to Wind (T).....	31
Support forum.....	66
System example .....	17

## T

Tacking .....	37
Technical support.....	64, 66
Training courses.....	66
Troubleshooting .....	58
Diagnostics .....	60
Network LED diagnostics.....	59

## U

Upgrading, software.....	19
--------------------------	----

## W

Warranty.....	10, 64
Waypoint .....	49
Waypoint arrival .....	33
WEEE Directive .....	10
Wind shift.....	35
Wind vane mode .....	35
Gybing .....	38
Tacking .....	37

## X

XTE .....	33
Restart .....	33