



Raymarine®

RCU-1 & WG-1

Installation Instructions

Legal notices

Trademark and patents notice

Raymarine®, Tacktick®, Pathfinder®, Clear Pulse®, Truzoom®, SeaTalk®, SeaTalk HS™, SeaTalk NG™, and MicroNet™, are registered or claimed trademarks of Raymarine UK Ltd.

FLIR®, Fishidy®, Fishing Hot Spots®, YachtSense™, DockSense®, RangeFusion™, DownVision®, SideVision®, RealVision®, HyperVision™, Wi-Fish®, Dragonfly®, Element®, Quantum®, Cyclone™, Alpha™, Axiom®, Infrared Everywhere, The World's Sixth Sense and ClearCruise® are registered or claimed trademarks of Teledyne FLIR LLC.

All other trademarks, trade names, or company names referenced herein are used for identification only and are the property of their respective owners.

This product is protected by patents, design patents, patents pending, or design patents pending.

Fair Use Statement

You may print no more than three copies of this manual for your own use. You may not make any further copies or distribute or use the manual in any other way including without limitation exploiting the manual commercially or giving or selling copies to third parties.

Content notice

Please ensure that you have obtained this document only from Raymarine, and that it is the **latest** available version.

There are numerous third-party Internet websites (such as www.manualslib.com) hosting Raymarine product manuals. These websites are not authorized by Raymarine to do so, and are often hosting illegitimate or older versions of Raymarine product manuals, which may contain inaccurate or misleading information.

To obtain the latest official documentation for a Raymarine product, please visit the official Raymarine website: www.docs.raymarine.com

Artificial Intelligence (AI) content notice

There are numerous third-party **Artificial Intelligence (AI)** services available to the public, which are capable of providing a summary or transcription of the information provided by official Raymarine publications or websites, either in written or audio/video formats. These services may alter, supplement, or convey the original information provided by Raymarine in inaccurate or misleading ways.

Please ensure that you have obtained this document only from Raymarine, and that it is the **latest** available version.

CONTENTS

CHAPTER 1 IMPORTANT INFORMATION	8	Technical accuracy	12
Safety warnings.....	8	Publication copyright.....	12
Product warnings.....	9	CHAPTER 2 DOCUMENT INFORMATION	13
Battery operation	9	2.1 Applicable products	14
Regulatory notices.....	9	2.2 Document information	14
UK Compliance statement.....	9	2.3 Product documentation	14
FCC RF Exposure	9	Obtain the latest documentation	14
Compliance Statement (Part 15.19)	9	Calibration and commissioning	
FCC Interference Statement (Part 15.105		instructions.....	14
(b))	10	Operation instructions	14
ISED RF Exposure	10	2.4 Document conventions.....	15
ISED RF Exposure (Français)	10	2.5 Document illustrations.....	15
Innovation, Sciences et Développement		CHAPTER 3 PRODUCT AND SYSTEM	
économique Canada (Français).....	10	OVERVIEW	16
Innovation, Science and Economic		3.1 Product overview	17
Development Canada (ISED)	10	3.2 Compatible gateway	17
CE Operating temperature and compliance		3.3 Compatible autopilot systems	17
statement.....	10	3.4 System example	18
NCC Compliance statement (Taiwan).....	11	3.5 Software updates.....	18
SRRC Compliance statement (China)	11	CHAPTER 4 PARTS SUPPLIED	20
Declaration of Conformity	11	4.1 Parts supplied	21
PSTI Compliance.....	11	4.2 Additional parts supplied	21
Disclaimer	11	CHAPTER 5 PRODUCT DIMENSIONS	22
Water ingress	11	5.1 Product dimensions — Autopilot remote	
Warranty policy and registration.....	12	control	23
Battery disposal.....	12	5.2 Product dimensions — Wireless	
Product disposal.....	12	gateway	23
IMO and SOLAS.....	12		

CHAPTER 6 LOCATION REQUIREMENTS	24	Cable shielding.....	38
6.1 Warnings and cautions.....	25	Connecting cables.....	38
6.2 Location requirements — Autopilot remote control	25	10.2 System example	38
6.3 Location requirements — Wireless gateway	25	10.3 Connecting DeviceNet cables	39
Compass safe distance.....	26	CHAPTER 11 POWER CONNECTION (WIRELESS GATEWAY)	40
6.4 Wireless location requirements for optimum performance.....	26	11.1 SeaTalk NG power supply.....	41
CHAPTER 7 MOUNTING — AUTOPILOT REMOTE CONTROL CRADLE.....	28	Inline fuse requirement.....	41
7.1 Tools required for installation	29	Inline fuse and thermal breaker ratings.....	41
7.2 Mounting the cradle	29	11.2 12 Volt dc only	42
CHAPTER 8 MOUNTING — WIRELESS GATEWAY	30	11.3 SeaTalk NG power cables.....	42
8.1 Wireless gateway mounting options	31	11.4 SeaTalk NG power cable extension	42
8.2 Tools required for surface mounting	31	11.5 SeaTalk NG product loading.....	43
8.3 Surface mounting using the studs and finger nuts	32	11.6 SeaTalk NG power connection point.....	43
CHAPTER 9 WIRELESS CONNECTION	33	11.7 SeaTalk NG system loading	43
9.1 Remote control Bluetooth connection.....	34	11.8 Power distribution — SeaTalk NG.....	44
9.2 Manual Bluetooth pairing.....	34	11.9 Power connection via Autopilot Control Unit (ACU-Series).....	46
9.3 Initiate Bluetooth pairing from a chartplotter.....	35	CHAPTER 12 OPERATIONS	47
CHAPTER 10 CABLES AND CONNECTIONS — GENERAL INFORMATION.....	36	12.1 Inserting batteries	48
10.1 General cabling guidance	37	12.2 Connecting the lanyard.....	48
Cable types and length	37	12.3 Using the cradle.....	48
Cable routing and bend radius.....	37	12.4 Controls	49
Strain relief.....	37	12.5 Operation instructions	50
Circuit isolation.....	37	CHAPTER 13 TROUBLESHOOTING	51
		13.1 Troubleshooting	52
		13.2 Wireless troubleshooting	52
		13.3 LED diagnostic guidance.....	54
		13.4 WG-1 LED diagnostics	55
		CHAPTER 14 MAINTENANCE.....	57

14.1 Routine equipment checks.....	58	18.2 Accessories — Wireless gateway.....	70
14.2 Cleaning the unit.....	58	18.3 SeaTalk NG cables and accessories	70
14.3 Replacing the batteries.....	58		
Battery disposal.....	58		
CHAPTER 15 TECHNICAL SUPPORT	59	APPENDIX A NMEA 2000 PGN SUPPORT	75
15.1 Raymarine technical support and servicing	60		
15.2 Learning resources	61		
15.3 Viewing product information.....	61		
15.4 Viewing product information from a chartplotter.....	62		
CHAPTER 16 TECHNICAL SPECIFICATION — AUTOPILOT REMOTE CONTROL	63		
16.1 Physical specification	64		
16.2 Battery specification	64		
16.3 Environmental specification	64		
16.4 AHRS specification	64		
16.5 Bluetooth specification	64		
16.6 Conformance specification.....	65		
16.7 Product markings	65		
CHAPTER 17 TECHNICAL SPECIFICATION — WIRELESS GATEWAY	66		
17.1 Physical specification	67		
17.2 Power specification	67		
17.3 Environmental specification	67		
17.4 Bluetooth specification	67		
17.5 Conformance specification.....	67		
17.6 Product markings	68		
CHAPTER 18 SPARES AND ACCESSORIES.....	69		
18.1 Spares — Autopilot remote control.....	70		

CHAPTER 1: IMPORTANT INFORMATION

Safety warnings



Warning: Product installation and operation

- This product must be installed and operated in accordance with the instructions provided. Failure to do so could result in personal injury, damage to your vessel and/or poor product performance.
- Certified installation by an approved installer is recommended. A certified installation qualifies for enhanced product warranty benefits. Contact your dealer for further details.



Warning: Aid to navigation

This product is intended only as an aid to navigation and must never be used in preference to sound navigational judgment. It is the user's responsibility to use official government charts, notices to mariners, caution and proper navigational skill when operating this or any other Raymarine product.



Warning: Maintain a permanent watch

Always maintain a permanent watch, this will allow you to respond to situations as they develop. Failure to maintain a permanent watch puts yourself, your vessel and others at serious risk of harm.



Warning: Potential ignition source

This product is NOT approved for use in hazardous/flammable atmospheres. Do NOT install in a hazardous/flammable atmosphere (such as in an engine room or near fuel tanks).



Warning: Battery safety

Before handling, installing or using your batteries, ensure that you have read and understood the safety related information provided below.

- Keep batteries away from children.
 - Do NOT expose batteries to sources of excessive heat, flame or sparks.
 - Do NOT drop, throw, crush, or attempt to disassemble the batteries.
 - Do NOT use batteries if they are damaged.
 - Do NOT submerge batteries.
 - Do NOT short the battery terminals.
 - Do NOT operate the batteries outside of their operating temperature range. Refer to the product's *Technical Specification* for more information.
 - Ensure batteries are disposed of in accordance with applicable local laws and regulations.
 - Do NOT use solvents or solvent-based cleaning agents to clean batteries.
 - Contact with battery acid may cause irritation or chemicals burns; irritation may occur to the eyes, skin or respiratory system. If contact is made, flush with clean water immediately. Seek medical advice.
- Failure to adhere to the above guidelines may result in shortened battery life, irreparable damage to your battery, risk of damage to the device, fire, acid leakage, or injury to persons (such as chemical burns).



Warning: Battery care

Before handling, installing or using your batteries, ensure you have read and understood the information provided below.

- Ensure batteries are disconnected before storing the product for a prolonged period.
- Always store batteries in a cool, dry and well-ventilated area, and NOT in direct sunlight.
- Do NOT leave batteries in high temperature areas such as in a vehicle on a sunny day.
- Do NOT store batteries outside of their storage temperature range. Refer to the product's *Technical Specification* for more information.

Failure to adhere to the above guidelines may result in shortened battery life, irreparable damage to your battery, risk of damage to the device, fire, acid leakage, or injury to persons (such as chemical burns).

Product warnings

Battery operation

Battery care and operation guidance.

- When used in colder temperatures, the batteries will discharge more quickly than in warmer conditions.
- When using a high display brightness, the batteries will discharge more quickly.
- Stored batteries will slowly discharge over time.
- The batteries are recyclable, and you must follow local laws and regulations for safe battery disposal.
- The batteries are sealed, maintenance-free units.

Caution: Float recommendation

It is recommended that you attach a float to the remote's lanyard so that it can be retrieved if dropped overboard.

Caution: Service and maintenance

This product contains no user serviceable components. Please refer all maintenance and repair to authorized Raymarine dealers. Unauthorized repair may affect your warranty.

Regulatory notices

UK Compliance statement

This product complies with the *Statutory Instrument 1206 Radio Equipment Regulations 2017*.

This product transmits within the frequency ranges of **less than or equal to**:

- 2402 MHz – 2480 MHz, less than 20 dBm

FCC RF Exposure

This product complies with the FCC (portable) RF exposure limits set forth for an uncontrolled environment. This product is safe for intended operation as described in this document.

This Transmitter product must not be co-located or operated in conjunction with any other antenna or transmitter.

Compliance Statement (Part 15.19)

This device complies with Part 15 of the FCC Rules. Operation is subject to the following two conditions:

1. This device may not cause harmful interference.
2. This device must accept any interference received, including interference that may cause undesired operation.



Warning: FCC Warning (Part 15.21)

Changes or modifications to this equipment not expressly approved in writing by Raymarine UK Ltd could violate compliance with FCC rules and void the user's authority to operate the equipment.

FCC Interference Statement (Part 15.105 (b))

This equipment has been tested and found to comply with the limits for a Class B digital device, pursuant to Part 15 of the FCC Rules.

These limits are designed to provide reasonable protection against harmful interference in a residential installation. This equipment generates, uses, and can radiate radio frequency energy and, if not installed and used in accordance with the instructions, may cause harmful interference to radio communications. However, there is no guarantee that interference will not occur in a particular installation. If this equipment does cause harmful interference to radio or television reception, which can be determined by turning the equipment off and on, the user is encouraged to try to correct the interference by one of the following measures:

1. Reorient or relocate the receiving antenna.
2. Increase the separation between the equipment and receiver.
3. Connect the equipment into an outlet on a circuit different from that to which the receiver is connected.
4. Consult the dealer or an experienced radio / TV technician for help.

ISED RF Exposure

Radiation Exposure Statement: The product complies with US and Canadian exposure limits for portable RF devices set forth for an uncontrolled environment. This product is safe for intended operation as described in this document.

RF exposure reduction can be achieved by keeping the device as far from the user's body as possible, or by setting the device to a lower output power, if such function is available.

ISED RF Exposure (Français)

Déclaration d'exposition aux radiations: Le produit est conforme aux limites d'exposition pour les appareils portables RF pour les États-Unis et le Canada établies pour un environnement non contrôlé. Le produit est sûr pour un fonctionnement tel que décrit dans ce manuel.

La réduction aux expositions RF peut être augmentée si l'appareil peut être conservé aussi loin que possible du corps de l'utilisateur ou que le dispositif est réglé sur la puissance de sortie la plus faible si une telle fonction est disponible.

Innovation, Sciences et Développement économique Canada (Français)

Cet appareil est conforme aux normes d'exemption de licence RSS.

Son fonctionnement est soumis aux deux conditions suivantes:

1. cet appareil ne doit pas causer d'interférence, et
2. cet appareil doit accepter toute interférence, notamment les interférences qui peuvent affecter son fonctionnement.

Cet appareil numérique de la classe B est conforme à la norme NMB-003 du Canada.

Innovation, Science and Economic Development Canada (ISED)

This device complies with License-exempt RSS standard(s).

Operation is subject to the following two conditions:

1. This device may not cause interference; and
2. This device must accept any interference, including interference that may cause undesired operation of the device.

This Class B digital apparatus complies with Canadian ICES-003(B) / NMB-003(B).

CE Operating temperature and compliance statement

Operating temperature:

This product's operational temperature range is: -25°C (-13°F) to + 55°C (131°F).

Compliance statement:

This product complies with the *2014/53/EU Radio Equipment Directive (RED)*.

In accordance with Article 10.8(a) and 10.8(b) of the RED, the following table provides information on the frequency bands used and the maximum EIRP (Effective Isotropic Radiated Power) of the product for sale in the EU:

Frequency Range	Maximum EIRP
Bluetooth 2.4GHz	7.89 dBm

NCC Compliance statement (Taiwan)

取得審驗證明之低功率射頻器材，非經核准，公司、商號或使用者均不得擅自變更頻率、加大功率或變更原設計之特性及功能。

低功率射頻器材之使用不得影響飛航安全及干擾合法通信；經發現有干擾現象時，應立即停用，並改善至無干擾時方得繼續使用。

前述合法通信，指依電信管理法規定作業之無線電通信。

低功率射頻器材須忍受合法通信或工業、科學及醫療用電波輻射性電機設備之干擾。

SRRC Compliance statement (China)



2023/7/1起“使用微功率短距离无线电发射设备应当符合国家无线电管理有关规定”

Declaration of Conformity

Declaration of Conformity for product sold into European Union (EU) member state regions, and the United Kingdom (UK).

Raymarine UK Ltd declares that the radio equipment type products listed below are in conformity with the relevant sections of the listed designated standards and / or other normative documents:

- RCU-1 Autopilot Remote Control, part number: A80835.
- RCU-1 Autopilot Remote Control with WG-1 Wireless Gateway, part number: E70718.

Region	Standard	Mark
UK	EMC Regulations 2016	
EU	Radio Equipment Directive 2014/53/EU	

The original Declaration of Conformity certificates may be obtained via the documentation page at www.bit.ly/RCU-1-docs

PSTI Compliance

For products sold into the United Kingdom (UK), use the following link to obtain the product's Statement of Compliance with the *Product Security and Telecommunications Infrastructure* (PSTI) Regulations:

Visit the following web address and enter the product's model name or number (SKU) into the provided search field:

[Important information](#)

- www.bit.ly/rym-sec-com

Disclaimer

Raymarine does not warrant that this product is error-free or that it is compatible with products manufactured by any person or entity other than Raymarine.

Raymarine is not responsible for damages or injuries caused by your use or inability to use the product, by the interaction of the product with products manufactured by others, or by errors in information utilized by the product supplied by third parties.

Third-party hardware, such as converters, adapters, routers, switches, Access Points etc., provided by third parties, may be made available directly to you by other companies or individuals under separate terms and conditions, including separate fees and charges. Raymarine UK Ltd or its affiliates have not tested or screened the third-party hardware.

Raymarine has no control over, and is not responsible for:

- (a) the content and operation of such third-party hardware; or
- (b) the privacy or other practices of such third-party hardware.

The fact that Raymarine's documentation may make reference to such third-party hardware does not indicate any approval or endorsement of any such third-party hardware. Raymarine may reference such third-party hardware only as a convenience.

THIS INFORMATION IS MADE AVAILABLE BY Raymarine ON THE BASIS THAT YOU EXCLUDE TO THE FULLEST EXTENT LAWFULLY PERMITTED ALL LIABILITY WHATSOEVER FOR ANY LOSS OR DAMAGE HOWSOEVER ARISING OUT OF THE USE OF THIS INFORMATION OR RELIANCE UPON THIS INFORMATION.

Raymarine does not exclude **Raymarine's** liability (if any) to you for personal injury or death resulting from **Raymarine UK Ltd** negligence, for fraud or for any matter which it would be illegal to exclude or to attempt to exclude.

Water ingress

Water ingress disclaimer

Although the waterproof rating capacity of this product meets the stated water ingress protection standard (refer to the product's *Technical Specification*), water intrusion and subsequent equipment

failure may occur if the product is not installed correctly or subjected to high-pressure washing. Raymarine will not warrant products subjected to high-pressure washing.

Warranty policy and registration

Visit the Raymarine website to **read the latest warranty policy**, and **register** your product's warranty online: www.bit.ly/rym-warranty

It is important that you register your product to receive full warranty benefits. Your product package includes a barcode label indicating the serial number of the unit. This serial number is also provided on a label affixed to the product itself. You will need this serial number when registering your product online.

Battery disposal

Consumers in European Union (EU) Member State regions are required to dispose of the battery (or batteries) included with this product in accordance with the EU Battery Directive (2006/66/EC).

The Battery Directive requires the proper waste management of batteries, including their recycling, collection, take-back programs, and disposal. The purpose of the Directive is to ensure the appropriate management of waste batteries which contain materials and chemicals that may be hazardous and present a risk to human health and / or the environment, when not handled correctly.

Local authorities in many regions have established collection schemes under which residents can dispose of waste batteries at a recycling center or other collection point. For a list of relevant websites for each region, visit: www.bit.ly/rym-recycling

Product disposal

Dispose of this product in accordance with the WEEE Directive.

The Waste Electrical and Electronic Equipment (WEEE) Directive requires the recycling of waste electrical and electronic equipment which contains materials, components and substances that may be hazardous and present a risk to human health and the environment when WEEE is not handled correctly.

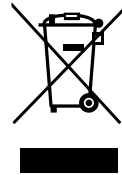

Equipment marked with the crossed-out wheeled bin symbol indicates that the equipment should not be disposed of in unsorted household waste. Local authorities in many regions have established collection schemes under which residents can dispose of waste electrical and electronic equipment at a recycling center or other collection point. For more information about suitable collection points for waste electrical and electronic equipment in your region, refer to the Raymarine website: <https://bit.ly/rym-recycling>

IMO and SOLAS

The equipment described within this document is intended for use on leisure marine boats and workboats NOT covered by International Maritime Organization (IMO) and Safety of Life at Sea (SOLAS) Carriage Regulations.

Technical accuracy

To the best of our knowledge, the information in this document was correct at the time it was produced. However, Raymarine cannot accept liability for any inaccuracies or omissions it may contain. In addition, our policy of continuous product improvement may change specifications without notice. As a result, Raymarine cannot accept liability for any differences between the product and this document. Please check the Raymarine website to ensure you have the most up-to-date version(s) of the documentation for your product: www.docs.raymarine.com

Publication copyright

Copyright ©2026 Raymarine UK Ltd. All rights reserved. No parts of this material may be copied, translated, or transmitted (in any medium) without the prior written permission of Raymarine UK Ltd.

CHAPTER 2: DOCUMENT INFORMATION

CHAPTER CONTENTS

- [2.1 Applicable products — page 14](#)
- [2.2 Document information — page 14](#)
- [2.3 Product documentation — page 14](#)
- [2.4 Document conventions — page 15](#)
- [2.5 Document illustrations — page 15](#)

2.1 Applicable products

This document is applicable to the following products:

- **RCU-1** Autopilot Remote Control, part number: A80835
- **RCU-1** Autopilot Remote Control with **WG-1** Wireless Gateway, part number: E70718

2.2 Document information

This document contains important information related to the installation of your Raymarine product.

The document includes information to help you:

- Plan your installation and ensure you have all the necessary equipment.
- Install and connect your product as part of a wider system of connected marine electronics.
- Troubleshoot problems and obtain technical support if required.

This and other Raymarine product documents are available to download in PDF format from www.bit.ly/rym-docs

2.3 Product documentation

The following documentation is applicable to your product:

RCU-1 applicable documents

Document	Description
87492	RCU-1 Remote Autopilot Controller Installation Instructions
87491	RCU-1 Cradle Mounting Template
81426	RCU-1 Operation Instructions

WG-1 applicable documents

Document	Description
87493	WG-1 Wireless Gateway Installation Instructions
87496	WG-1 Wireless Gateway Mounting Template.

Related documents

Document	Description
81406	LightHouse 4 Advanced Operation Instructions
81402	p70s/p70Rs/p70/p70R Operation Instructions
87281	Deck Mounting Kit Installation Instructions. (Provides alternative mounting methods for the WG-1 wireless gateway).
87274	Pole / Rail Mount Adaptor Accessory Installation Instructions (Provides alternative mounting methods for the WG-1 wireless gateway).

Obtain the latest documentation

This document may not reflect the latest information available for your product. Please ensure that you obtain the **latest version** of documentation for your product from the Raymarine website.

QR code	Link
	www.bit.ly/RCU-1-docs

Calibration and commissioning instructions

The RCU-1 cannot be used to calibrate or commission your autopilot.

Please refer to the commissioning instructions supplied with your autopilot controller.

Operation instructions

For detailed operation instructions, refer to the dedicated *RCU-1 Autopilot Remote Control Operation Instructions* (Document number: 81426): www.bit.ly/RCU-1-docs

2.4 Document conventions

The following conventions are used throughout this document.

Formatting of user interface menus and settings.

References to menus, setting options and physical buttons are formatted using square brackets [].

Examples:

- “You can select your desired cartography from the *[Cartography selection]* menu.”
- “MFD apps are accessed from the *[Homescreen]*.”
- “Press the *[Home]* button to return to the Homescreen.”

Procedures for performing specific tasks using the product’s user interface.

The term “**Select**” is used to refer to the action of:

- Touchscreen control — using your finger to select a menu option or item on the screen.
- Physical buttons — Highlighting an item using the navigational controls and confirming the selection by pressing the *[OK]* button.

Examples:

- “Select *[Ok]* to confirm your selection.”
- “Select *[Set-up]*.”

Procedures for navigating menu hierarchies.

Menu hierarchies are used in this document to provide a quick summary on how to access a particular function or menu option.

Examples:

- “The internal sonar module is disabled using the Fishfinder app menu: *[Menu > Set-up > Sounder Set-up > Internal Sounder]*.”
- “The internal GPS can be switched off from the GPS settings menu: *[Homescreen > Status area > Satellites > Settings > Internal GPS]*.”

2.5 Document illustrations

While every effort is made to ensure that the illustrations provided in this publication accurately reflect the final released product, due to editorial and production lead times, your product — and if

applicable — its user interface, may differ slightly from the illustrations provided in this document, depending on product variant and date of manufacture.

All images are provided for illustration purposes only.

CHAPTER 3: PRODUCT AND SYSTEM OVERVIEW

CHAPTER CONTENTS

- 3.1 Product overview — page 17
- 3.2 Compatible gateway — page 17
- 3.3 Compatible autopilot systems — page 17
- 3.4 System example — page 18
- 3.5 Software updates — page 18

3.1 Product overview

The RCU-1 is a battery powered, handheld remote autopilot controller for Evolution-Series autopilot systems.

The RCU-1 is supplied with a pre-paired WG-1 Wireless Gateway when ordering part number E70718, or can be supplied as a standalone handset (part number A80835), for systems that already include a WG-1 Wireless Gateway.



Remote control features:

- Remote autopilot control — Engage, adjust, or disengage the autopilot from anywhere onboard.
- Powered by standard or rechargeable AA batteries (2 x alkaline batteries supplied).
- Full color, direct sunlight-viewable LCD screen.
- Wireless (Bluetooth) connection via the WG-1 Wireless Gateway.
- *[Point and Go]* button — Point the remote and press the button to initiate a GoTo in that direction.
- *[Solo sailor]* mode.
- Activate Man Overboard (MOB) alarm.
- View NMEA 2000 data.
- Built in AHRS (Attitude and Heading Reference System) sensor.
- Built in alarm buzzer.

- Remains fully operational when held in the cradle.
- 30 m (98.43 ft) line-of-sight operating distance from gateway.
- Approximate “In use” battery life: 30 hours.
- Approximate storage battery life: 365 days.
- Supplied with a lanyard.

3.2 Compatible gateway

The RCU-1 Autopilot Remote Control is compatible with the following wireless gateway:



- WG-1 Wireless Gateway, part number: R70947

3.3 Compatible autopilot systems

Your remote control is **only** compatible with Evolution-Series autopilot systems.

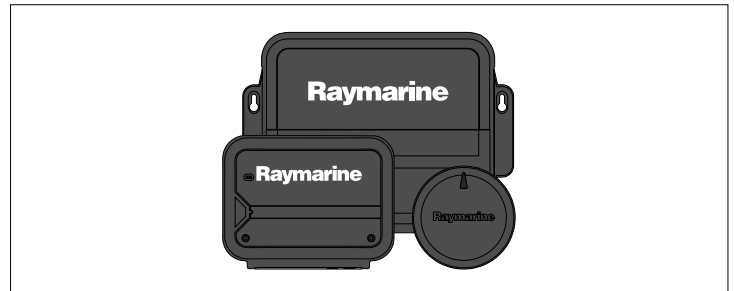

Note:

The EV-1 / EV-2 sensor requires software **v3.20**, or later.

Important:

The remote control is NOT compatible with any other Raymarine, or third-party autopilot systems.

3.4 System example

The following system example shows an RCU-1 Autopilot Remote Control connected to an autopilot system via the WG-1 Wireless Gateway.

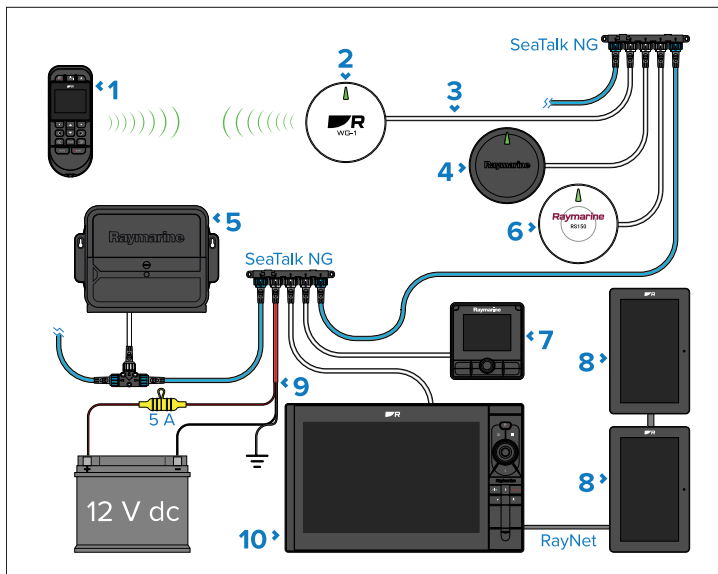

1. RCU-1 Remote Autopilot Controller.
2. WG-1 Wireless Gateway.
3. DeviceNet to SeaTalk NG adapter cable.
4. Evolution-Series sensor (e.g.: EV-1).

5. Evolution-Series ACU (e.g.: ACU-200).
6. RS150 GNSS (GPS) receiver.
7. p70Rs autopilot control head.
8. Alpha-Series displays.
9. SeaTalk NG power connection (12 V dc **only**).
10. Axiom 2 Pro chartplotter.

3.5 Software updates

Product software updates may be made available which add new features and improve existing functionality. It's important to ensure that you have the latest software for your products by regularly checking the Raymarine website for new software releases.

To check for the latest software updates and the software update procedure for your specific product(s), refer to: www.bit.ly/rym-software

Unless otherwise stated, software updates for Raymarine products are performed using a Raymarine MFD / chartplotter.

- Where applicable, you should always backup your user data and settings before performing a software update.
- To update SeaTalk NG products, you must use the datamaster MFD / chartplotter which is physically connected to the SeaTalk NG backbone.
- Ethernet (RayNet) products can be updated from any MFD / chartplotter on the same network as the product to be updated.
- In order to perform a software update, any connected Autopilot or Radar must be switched to Standby.
- The MFD / chartplotter "Check online" feature is only available when connected to the Internet.

Note:

If in doubt as to the correct procedure for updating your product software, refer to your dealer or Raymarine technical support.

Caution: Installing software updates

- The software update process is carried out at your own risk. Before initiating the update process ensure you have backed up any important files.
- Ensure that the product(s) has a reliable power supply and that the update process is not interrupted.
- Damage caused by an incomplete update is not covered by Raymarine warranty.
- By downloading the software update package, you agree to these terms.

CHAPTER 4: PARTS SUPPLIED

CHAPTER CONTENTS

- 4.1 Parts supplied — page 21
- 4.2 Additional parts supplied — page 21

4.1 Parts supplied

The following parts are supplied in the box, when ordering the **RCU-1 Autopilot Remote Control**, part number: A80835. Additional parts are supplied when ordering the **RCU-1 Autopilot Remote Control with WG-1 Wireless Gateway**, part number: E70718.

Unpack your product carefully to prevent damage or loss of parts. Check the box contents against the list below. Retain the packaging and documentation for future reference.

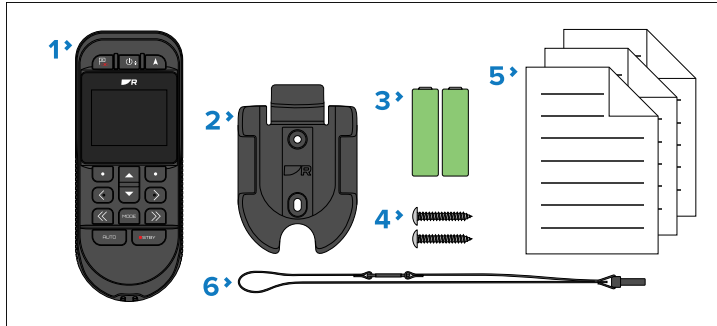

Description	
1	RCU-1 Autopilot Remote Control.
2	Cradle.
3	2 x AA alkaline batteries.
4	2 x T4x25 self tapping screws.
5	Documentation pack.
6	Lanyard.

4.2 Additional parts supplied

The following additional parts are supplied in the box when ordering the **RCU-1 Autopilot Remote Control with WG-1 Wireless Gateway**, part number: E70718.

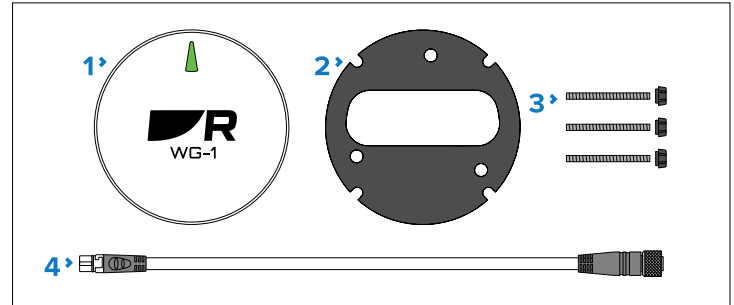

Description	
1	WG-1 Wireless Gateway.
2	WG-1 Wireless Gateway waterproof gasket.
3	3 x M4x40 threaded studs and finger nuts (for mounting the Wireless Gateway).
4	SeaTalk NG to DeviceNet adapter cable, 6 m (19.69 ft).

CHAPTER 5: PRODUCT DIMENSIONS

CHAPTER CONTENTS

- 5.1 Product dimensions — Autopilot remote control — page 23
- 5.2 Product dimensions — Wireless gateway — page 23

5.1 Product dimensions — Autopilot remote control

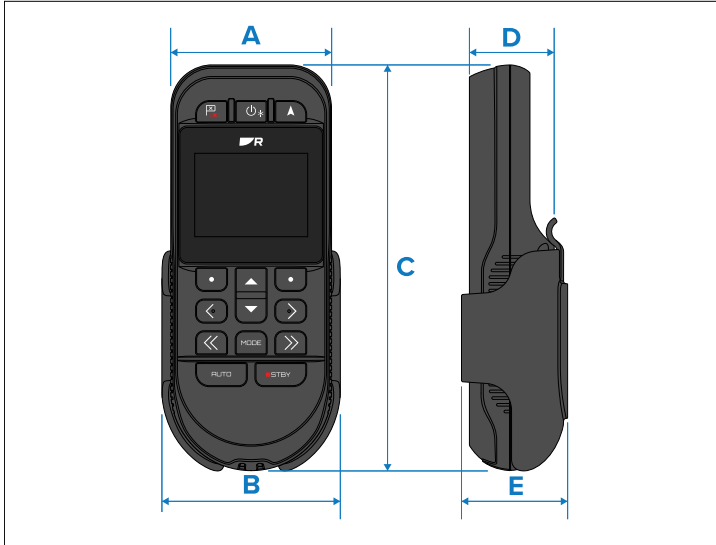

Dimension		Dimension	
A	59.83 mm (2.36 in)	B	66.32 mm (2.61 in)
C	150.87 mm (5.94 in)	D	31.51 mm (1.24 in)
E	39.55 mm (1.56 in)		

Dimension		Dimension	
A	108.48 mm (4.27 in)	B	26.61 mm (1.05 in)
C	9.5 mm (0.37 in)		

5.2 Product dimensions — Wireless gateway

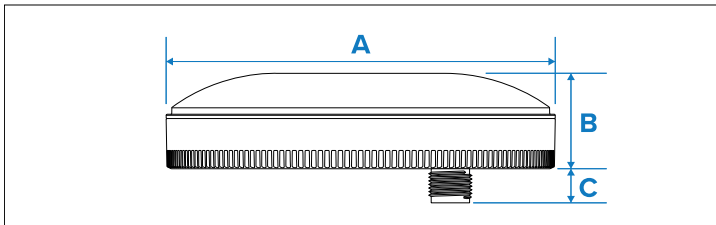

CHAPTER 6: LOCATION REQUIREMENTS

CHAPTER CONTENTS

- 6.1 Warnings and cautions — page 25
- 6.2 Location requirements — Autopilot remote control — page 25
- 6.3 Location requirements — Wireless gateway — page 25
- 6.4 Wireless location requirements for optimum performance — page 26

6.1 Warnings and cautions

Important:

Before proceeding, ensure that you have read and understood the warnings and cautions provided in the following section of this document:

- [p.8 — Important information](#)



Warning: Potential ignition source

This product is NOT approved for use in hazardous/flammable atmospheres. Do NOT install in a hazardous/flammable atmosphere (such as in an engine room or near fuel tanks).

6.2 Location requirements — Autopilot remote control

The product is portable; however, it remains fully operational whilst docked in its cradle. Consider the following important requirements when choosing a suitable location to mount the product.

The product is suitable for installation above or below decks.

The product should be mounted in a location where it will be:

- Protected from physical damage and excessive vibration.
- Well-ventilated and away from heat sources.
- Away from any potential ignition source such as an engine room, near fuel tanks or a gas locker.
- Easily accessible for operations.

To ensure reliable and trouble-free operation, also consider the following:

- **Access** — there must be sufficient space to enable the product to be inserted into and removed from its cradle.
- **Electrical interference** — the product should be mounted far enough away from any equipment that may cause interference, such as: engines, motors, generators, radio transmitters / receivers, and cables carrying high power.
- **Compass safe distance** — the product should be mounted at least **100 mm (3.94 in)** in all directions from any compasses.

- **Mounting surface** — ensure the product is adequately supported on a secure, flat surface.

6.3 Location requirements — Wireless gateway

Important requirements to consider when choosing a suitable location to mount the product.

- The product is suitable for installation above or below decks.
- Before installing the wireless gateway, a pre-installation test should be performed in order to gauge the connection reliability between the wireless gateway and the wireless device(s) that will connect to it.
- In optimum open air, clear line-of-sight conditions, a connection between the wireless gateway and the wireless device is possible up to distances of 30 m (98.43 ft). However, the maximum connection distance between the wireless gateway and wireless device will vary depending on the installation environment (i.e. obstructions and interference). In order to ensure optimum connection performance, both units should be mounted in accordance with the requirements specified under the following section: [p.26 — Wireless location requirements for optimum performance](#)
- On larger vessels (e.g.: >50 m (164 ft)) it is recommended that the wireless gateway is mounted amidships.
- The product must be mounted on a level surface.
- The product can be mounted on a vertical surface such as a bulkhead or mast etc, using the Bulkhead bracket supplied in the *Deck mounting kit*, part number: A80437. For more information, refer to the following documentation: '**87281 Deck Mounting Kit Installation Instructions**'.
- The product can be mounted on a pole or rail using the Pole mount adapter supplied in the *Pole / Rail mounting adapter kit*, part number: A80370. For more information, refer to the following documentation: '**87274 Pole / Rail Mount Adapter — Accessory Installation Instructions**'.
- Do NOT mount the product on top of a mast.
- The product location must be at least 1 m (3.28 ft.) away from sources that can cause interference, such as compasses, electrical

cables, motors, generators, VHF radio units and other transmitters / receivers.

- Ensure that the product is NOT mounted in the path of the beam emitted from radar scanners.
- Choose a location where the product will be safe from physical damage and excessive vibration.
- Choose a location where the product will not be subjected to a load or force.
- Mount the product away from any source of heat or potential flammable hazards, such as fuel vapor.
- The product should be mounted in a location where the diagnostics LED is viewable.

Note:

Product orientation is not important, but aesthetically the product may look better with the LED 'arrow' pointing towards the vessel's bow.

Compass safe distance

To prevent potential interference with the vessel's magnetic compasses, ensure an adequate distance is maintained from the product.

When choosing a suitable location for the product, you must aim to maintain a distance of **at least 1 m (3.3 ft.)** in all directions from any compasses.

For some smaller vessels it may not be possible to locate the product this far away from a compass. In this situation, when choosing the installation location for your product, ensure that the compass is not affected by the product when it is in a powered on state.

6.4 Wireless location requirements for optimum performance

All wireless devices in your system must be located in such a way that they can reliably receive and/or transmit wireless signals.

A number of factors can influence wireless performance. For example, physical obstacles and certain vessel structures and materials can all negatively impact wireless performance. Therefore, **it's important to check a product's wireless performance at the desired installation location before drilling any mounting holes.**

Vessel construction and materials

Wherever possible, mount products on surfaces constructed from GRP (e.g. fiberglass resin, or foam), or on dry wooden bulkheads. **Conductive materials in the signal path can have a significant impact on wireless signal performance.** Reflective surfaces such as metal surfaces, some types of glass and even mirrors can drastically affect performance or even block the wireless signal. Installation locations that are in close proximity to these materials should be avoided. **Do NOT mount wireless products directly to conductive materials.** This includes any mounting surface or enclosure/pod. Examples of conductive materials include, but are not limited to:

- carbon fibre, kevlar, or aramid (including sails made from these materials)
- aluminium
- steel

In installations with conductive materials, if available, mount the wireless product using an accessory pole mount or deck mounting kit. A clearance of at least 10 cm (3.9 in) is required to minimize the ground effect from conductive materials. This applies to transmitters as well as displays. If moving the product fixes the problem, consider cutting an antenna clearance hole behind the unit (once the product position and mounting have been finalized).

Wireless performance can also be degraded in locations where the wireless signal passes through a bulkhead containing power cables. Crew members (especially when wet) can also be obstructive to wireless signals, if their bodies pass through the signal area between wireless sensor and any associated displays.

Checking and optimizing signal strength

It may be necessary to experiment with the location of your wireless products to achieve optimal wireless performance and a clear signal path.

The distance between wireless products should always be kept to a minimum. Do not exceed the maximum stated range of your wireless product (maximum range will vary for each device).

Wireless performance degrades over distance, so products farther away will receive less network bandwidth. Products installed close to their maximum wireless range may experience slow connection speeds, signal dropouts, or not being able to connect at all.

For best results, the wireless product should have a clear, direct line-of-sight to the product it will be connected to. Any physical obstructions can degrade or even block the wireless signal. Some wireless products feature a signal strength indicator to assist in the process of determining the location with the best wireless performance. Choose the location with the highest and most consistently strong direct signal reading, during a 5 minute monitoring period. Try alternative locations for the transmitter to maximize the signal strength to the displays; e.g. try locations below a hatch or skylight or near to a window. A small change in product position can result in a significant change in the signal strength.

Note:

Some wireless products (e.g. a Hull Transmitter) will not transmit data unless a transducer is connected. Also consider that an NMEA or SeaTalk NG product (e.g. an interface) will not transmit data unless an appropriate data source is connected.

Interference and other equipment

Interference from other people's wireless devices can cause interference with your products. You can use a third-party wireless analyzer tool / smartphone app to assess the best wireless channel to use (e.g. a channel not in use or one used by the least number of devices).

Wireless products should be installed at least 1 m (3 ft) away from:

- Other wireless-enabled products
- Transmitting products that send wireless signals in the same frequency range
- Other electrical, electronic or electromagnetic equipment that may generate interference.

Software updates

It's also important to ensure all your wireless products are running the latest software versions, as improvements are made over time to wireless performance.

CHAPTER 7: MOUNTING — AUTOPILOT REMOTE CONTROL CRADLE

CHAPTER CONTENTS

- 7.1 Tools required for installation — page 29
- 7.2 Mounting the cradle — page 29

7.1 Tools required for installation

Product installation requires the following tools:

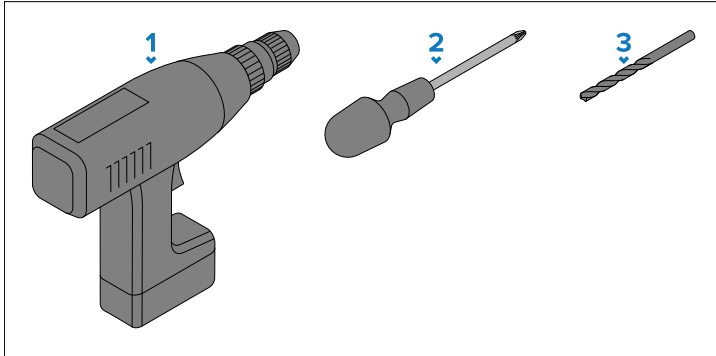

1. Power drill.
2. Pozi drive screwdriver.
3. Drill bit.

Note:

The appropriate drill bit size is dependent on the thickness and material of the mounting surface.

7.2 Mounting the cradle

Before mounting the product, ensure that you have selected a suitable location, based on the location requirements found in this document.

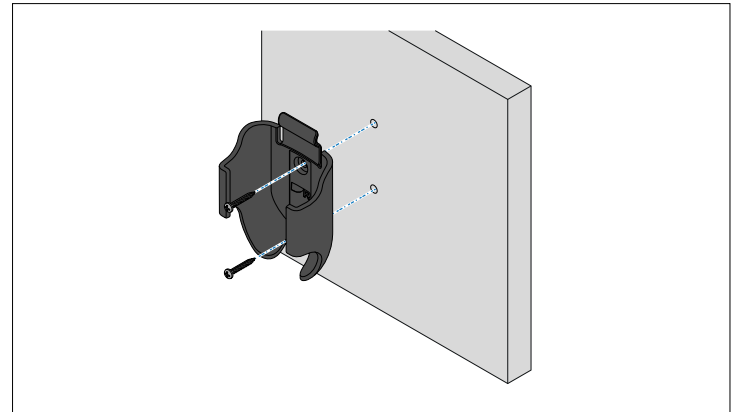

1. Fix the supplied mounting template to the chosen location, using masking or self-adhesive tape.
2. Drill the 2 pilot holes as indicated on the template.
3. Remove the mounting template.
4. Hold the cradle in place so that the mounting holes line up with the drilled holes in the mounting surface.
5. Secure the cradle to the mounting surface using the supplied fixings (2 x self tapping screws).

Note:

The supplied screws may not be suitable for all mounting surface types; ensure that you use fixings that are appropriate for your installation.

CHAPTER 8: MOUNTING — WIRELESS GATEWAY

CHAPTER CONTENTS

- 8.1 Wireless gateway mounting options — page 31
- 8.2 Tools required for surface mounting — page 31
- 8.3 Surface mounting using the studs and finger nuts — page 32

8.1 Wireless gateway mounting options

The following mounting options are available for the WG-1 Wireless Gateway:

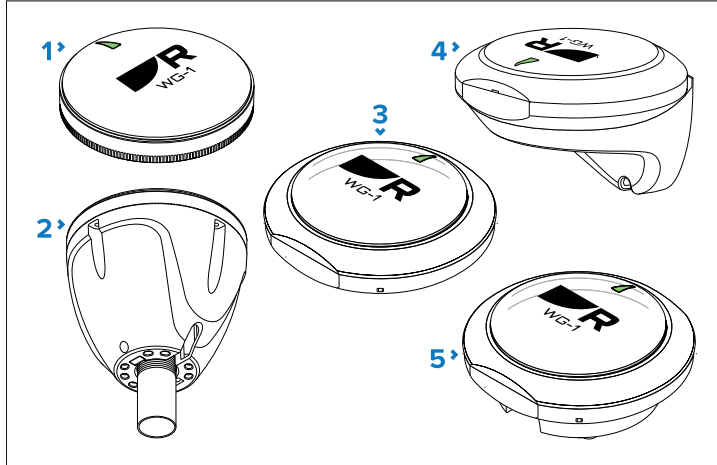

Mounting method	Required mounting kit	Instructions
Surface mounting (without <i>Mounting tray</i>)	Studs and finger nuts (supplied).	p.32 — Surface mounting using the studs and finger nuts
Pole / rail mounting	<i>Pole / Rail mounting adapter kit</i> (part number: A80370).	87274 <i>Pole / Rail Mount adapter — Accessory Installation Instructions</i>
Surface mounting (with <i>Mounting tray</i>)	<i>Deck mounting (Clamshell / Riser) kit</i> (part number: A80437).	87281 <i>Deck Mounting Kit Installation Instructions</i>

Mounting method	Required mounting kit	Instructions
Bulkhead mounting (with <i>Mounting tray</i> and <i>Bulkhead bracket</i>)	<i>Deck mounting (Clamshell / Riser) kit</i> (part number: A80437).	87281 <i>Deck Mounting Kit Installation Instructions</i>
Surface mounting (with <i>Riser</i> and <i>Mounting tray</i>)	<i>Deck mounting (Clamshell / Riser) kit</i> (part number: A80437).	87281 <i>Deck Mounting Kit Installation Instructions</i>

To obtain the mounting instructions listed above, visit: www.bit.ly/rym-docs

8.2 Tools required for surface mounting

The following tools are required for surface mount installations:

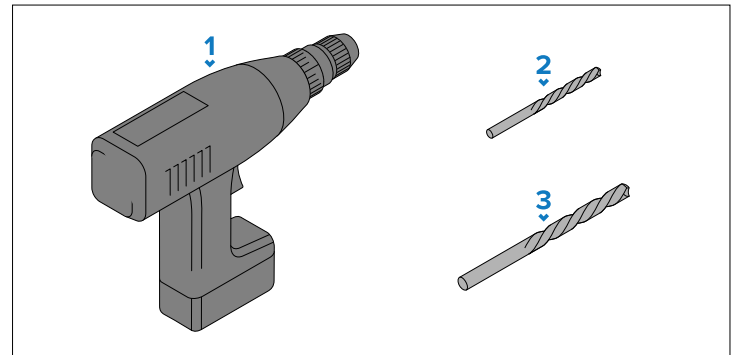

Description	
1	Power drill.
2	4 mm (¹ / ₆₄) drill bit.
3	22 mm drill bit (for connector/cable hole).

8.3 Surface mounting using the studs and finger nuts

The product can be mounted on a surface that is up to (approximately) 28 mm (1.10 in) thick, using the fixings supplied with the product. To mount on a thicker surface, longer studs will be required.

Ensure that the chosen location meets the product's location requirements; refer to: [p.24 — Location requirements](#)

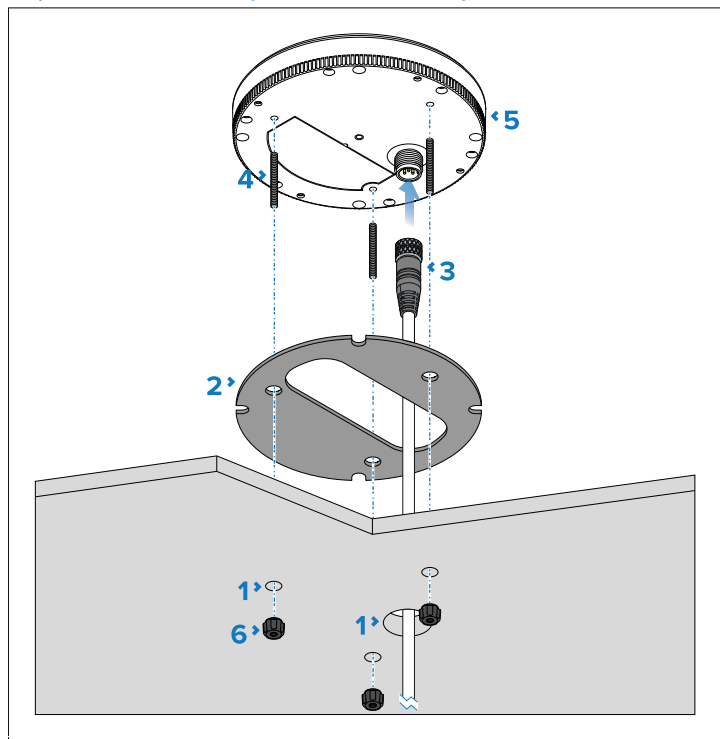

1. Using the supplied mounting template, drill 3 holes for the fixings and a hole for the connector / cable.
2. Place the waterproof gasket into position on the underside of the product.
3. Feed the cable up through the hole in the mounting surface. Connect the cable to the connector on the underside of the product, then secure by using the cable connector's locking mechanism. Connect the other end of the cable to an available spur connection.
4. Screw the threaded studs into the underside of the product (these should be hand-tight only).
5. Position the product so that the mounting studs pass through the holes in the mounting surface.
6. Secure the product to the mounting surface using the finger nuts (these should be hand-tight only).

CHAPTER 9: WIRELESS CONNECTION

CHAPTER CONTENTS

- 9.1 Remote control Bluetooth connection — page 34
- 9.2 Manual Bluetooth pairing — page 34
- 9.3 Initiate Bluetooth pairing from a chartplotter — page 35

9.1 Remote control Bluetooth connection

The RCU-1 uses a wireless Bluetooth connection to pair with the WG-1 Wireless Gateway.

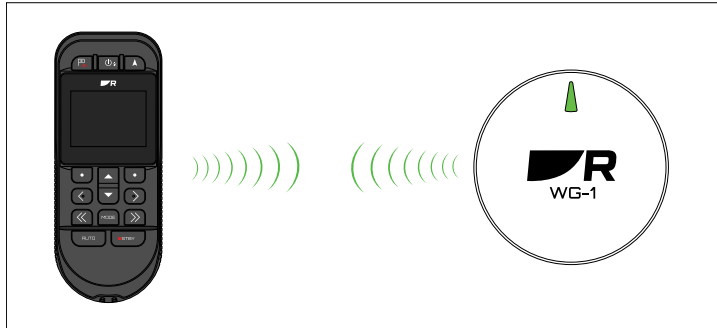

Note:

For optimum performance there should always be a clear line of sight between the remote control and wireless gateway.

9.2 Manual Bluetooth pairing

The remote control must be paired with the wireless gateway.

If your RCU-1 Autopilot Remote Control and WG-1 Wireless Gateway were purchased as a system pack (E70718), the remote control will be pre-paired to the wireless gateway. The remote control will automatically connect with the wireless gateway when it is powered on.

If you have purchased your remote control and wireless gateway separately (e.g. as a spare or accessory), the remote control will need to be manually paired to the wireless gateway.

When the remote is powered on, after accepting the *[Terms]* page, the remote will automatically start searching for wireless gateways.

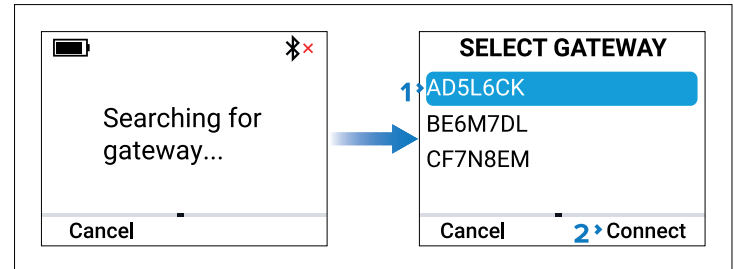

1. Use the *[Up]* and *[Down]* buttons to highlight your wireless gateway in the list of devices.

If more than one gateway is discovered, you can identify its serial number by checking its product label, or by checking the list of networked devices on a compatible chartplotter's Network settings menu: [Homescreen > Settings > Network].

2. Press the *[Connect]* (Right softkey) button.

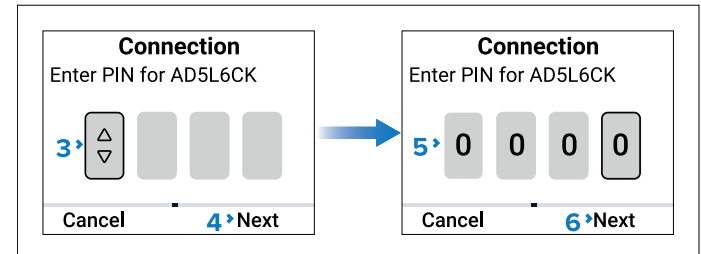

3. Enter the first digit of the PIN, using the *[Up]* and *[Down]* buttons.

Note:

The wireless gateway's PIN number is: **0000**.

4. Press the *[Next]* (Right softkey) button.
5. Repeat steps 3 and 4 for the remaining 3 PIN digits.

- After entering the fourth digit of the PIN, pressing the *[Next]* button will initiate the connection.

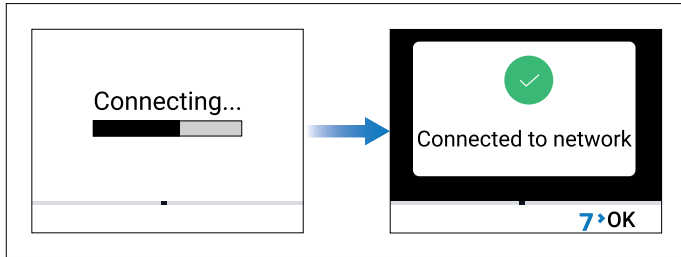

- Press the *[OK]* button when the “*Connected to network*” message is displayed.

Note:

If the pairing process fails, re-check the wireless gateway’s PIN number, power cycle the wireless gateway and the remote control, and then re-attempt pairing.

9.3 Initiate Bluetooth pairing from a chartplotter

If your remote control and wireless gateway have been purchased as a system pack (E70718), the remote control will be pre-paired to the wireless gateway out-of-the-box, and the remote control will connect to the wireless gateway when it is powered up. If you have purchased your remote control and wireless gateway separately (e.g. as a spare or accessory), the remote control will need to be manually paired to the wireless gateway. Pairing can be initiated from the *[Bluetooth connections]* page on a networked LightHouse 4 chartplotter.

To pair your remote control to the wireless gateway:

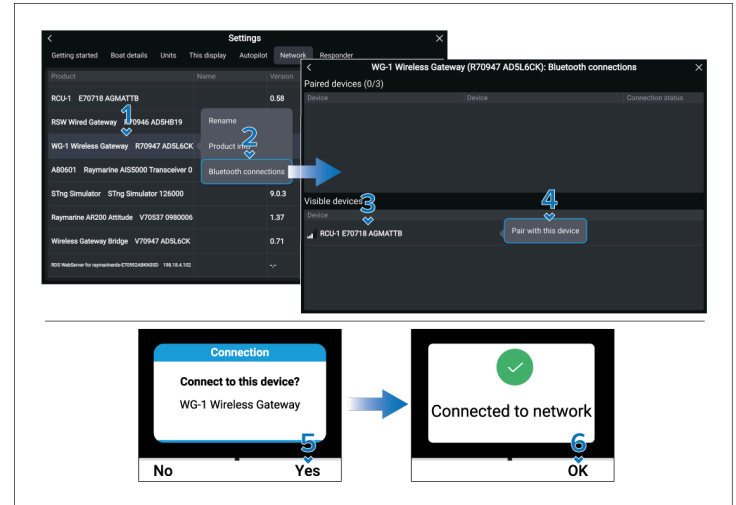

- Select your *[WG-1 Wireless Gateway]* from the list of devices in the *[Network]* settings menu: *[Homescreen > Settings > Network > WG-1 Wireless Gateway]* on your networked LightHouse 4 multifunction display/chartplotter.
- Select *[Bluetooth connections]* from the pop-over options.
- Select your remote control from the *[Visible devices]* list.
- Select *[Pair with this device]* from the pop-over options. Pairing on the remote control will be initiated.
- Select *[Yes]* on the remote control. The remote control will pair with the wireless gateway.
- Select *[OK]*.

Once paired, the remote control will appear in the *[Paired devices]* list and display the *[Connected]* status.

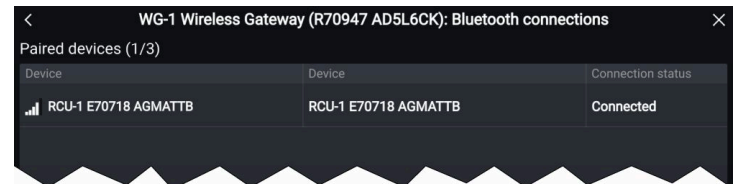

CHAPTER 10: CABLES AND CONNECTIONS — GENERAL INFORMATION

CHAPTER CONTENTS

- [10.1 General cabling guidance — page 37](#)
- [10.2 System example — page 38](#)
- [10.3 Connecting DeviceNet cables — page 39](#)

10.1 General cabling guidance

Cable types and length

It is important to use cables of the appropriate type and length.

- Unless otherwise stated only use cables supplied by Raymarine.
- Where it is necessary to use non-Raymarine cables, ensure that they are of correct quality and gauge for their intended purpose. (e.g.: longer power cable runs may require larger wire gauges to minimize voltage drop along the run).

Cable routing and bend radius

To maximize cable performance and lifespan, it's important to ensure that all cables are routed correctly and adequate space is provided to allow for each cable's minimum bend radius.

Minimum cable bend radius

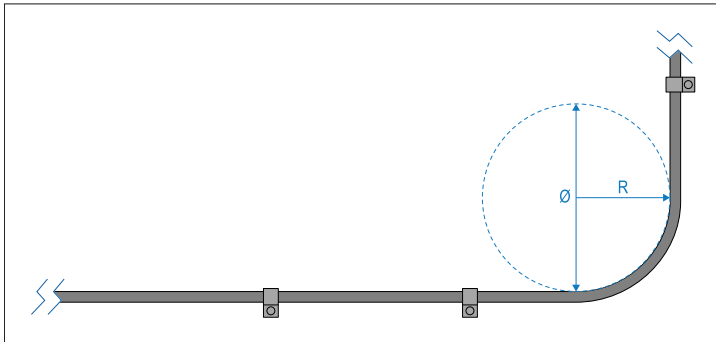

Do NOT bend cables excessively. Wherever possible, ensure that your chosen product installation location allows enough clearance for the minimum cable bend diameter specified in the following table:

	Description	Value
Ø	Cable minimum bend diameter .	200 mm (7.87 in.)
R	Cable minimum bend radius .	100 mm (3.94 in.)

Note:

For products where multiple different cable types are connected, each with a different minimum cable bend radius, the higher figure is provided in the table above (i.e. the cable with the greatest minimum bend radius is specified).

Cable routing — best practices

- Protect all cables from physical damage and exposure to heat. Use trunking or conduit where possible. Do NOT run cables through bilges or doorways, or close to moving or hot objects.
- Secure cables in place using cable clips or cable ties. Coil any excess cable and tie it out of the way.
- Where a cable passes through an exposed bulkhead or deckhead, use a suitable watertight feed-through (conduit).
- Do NOT run cables near to engines or fluorescent lights.
- Always route data cables as far away as possible from:
 - Other equipment and cables.
 - High current-carrying AC and DC power lines.
 - Antennas.

Strain relief

Use adequate strain relief for cabling to ensure that connectors are protected from strain and will not pull out under extreme sea conditions.

Circuit isolation

Appropriate circuit isolation is required for installations using both AC and DC current:

- Always use isolating transformers or a separate power-inverter to run PCs, processors, displays and other sensitive electronic instruments or devices.
- If using Weather FAX audio cables, always use an isolating transformer.
- If using a third-party audio amplifier, always use an isolated power supply.
- If using an RS232/NMEA converter, always ensure optical isolation on the signal lines.

- Always ensure that PCs or other sensitive electronic devices have a dedicated power circuit.

Cable shielding

Ensure that cable shielding is not damaged during installation and that all cables are properly shielded.

Important:

Be aware that some **third-party** cables and adapters (for example, certain Ethernet cables using RJ45 connectors) are not always shielded. To prevent breaks in cable shielding continuity and potential grounding issues, special attention is required to ensure that any cables, extension cables, adapters, or other signal-coupling devices used in cable runs **maintain all shield connections throughout the cable run.**

Connecting cables

Follow the steps below to connect the cable(s) to your product.

1. Ensure that the vessel's power supply is switched off.
2. Ensure that the device being connected has been installed in accordance with the installation instructions supplied with that device.
3. Ensuring correct orientation, push cable connectors fully onto the corresponding connectors.
4. Engage any locking mechanism to ensure a secure connection (e.g.: turn locking collars clockwise until tight, or in the locked position).
5. Ensure any bare ended wire connections are suitably insulated to prevent shorting and corrosion due to water ingress.

10.2 System example

The following system example shows an RCU-1 Autopilot Remote Control connected to an autopilot system via the WG-1 Wireless Gateway.

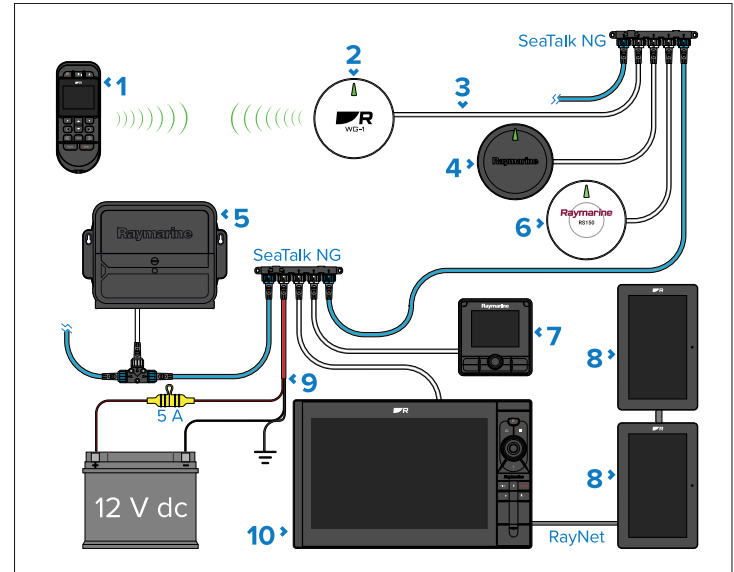

1. RCU-1 Remote Autopilot Controller.
2. WG-1 Wireless Gateway.
3. DeviceNet to SeaTalk NG adapter cable.
4. Evolution-Series sensor (e.g.: EV-1).
5. Evolution-Series ACU (e.g.: ACU-200).
6. RS150 GNSS (GPS) receiver.
7. p70Rs autopilot control head.
8. Alpha-Series displays.
9. SeaTalk NG power connection (12 V dc **only**).
10. Axiom 2 Pro chartplotter.

10.3 Connecting DeviceNet cables

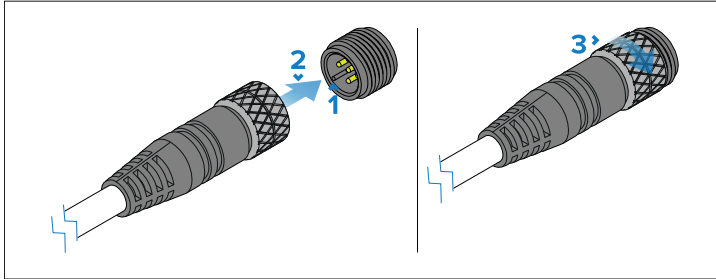

1. Ensure the inner groove on the cable's DeviceNet connector is correctly aligned with the inner groove on your product's DeviceNet connector.
2. Fully insert the cable connector.
3. Rotate the DeviceNet locking collar clockwise until the cable is secure.

CHAPTER 11: POWER CONNECTION (WIRELESS GATEWAY)

CHAPTER CONTENTS

- 11.1 SeaTalk NG power supply — page 41
- 11.2 12 Volt dc only — page 42
- 11.3 SeaTalk NG power cables — page 42
- 11.4 SeaTalk NG power cable extension — page 42
- 11.5 SeaTalk NG product loading — page 43
- 11.6 SeaTalk NG power connection point — page 43
- 11.7 SeaTalk NG system loading — page 43
- 11.8 Power distribution — SeaTalk NG — page 44
- 11.9 Power connection via Autopilot Control Unit (ACU-Series) — page 46

11.1 SeaTalk NG power supply

Your product is supplied power via the SeaTalk NG backbone (or the NMEA 2000 backbone if applicable).

A SeaTalk NG backbone requires a single 12 V dc power supply. Power can be supplied to the SeaTalk NG backbone by one of the following methods:

- ⁽¹⁾ Direct connection to a 12 V dc battery using an inline 5 amp fuse.
- Connection to a 12 V dc distribution panel using a 3 amp thermal breaker.
- ⁽²⁾ Connection to the SeaTalk NG connector of an ACU-Series Autopilot Control Unit (not ACU-100 or ACU-150), or an SPX-Series course computer (not SPX-5).
- For 24 V vessels, connection must be via a 5 amp, regulated, continuous 24 V dc to 12 V dc converter.

Note:

- ⁽¹⁾ The battery used for starting the vessel's engine(s) should NOT be used to power the SeaTalk NG backbone. If the SeaTalk NG backbone cannot be powered by an alternate power source, products may experience a loss of voltage when the vessel's engine(s) are started.
- ⁽²⁾ The ACU-100, ACU-150 or SPX-5 cannot be used to power the SeaTalk NG backbone.
- The course computer SeaTalk NG connector includes a power switch that must be in the On position to provide power to the backbone.

Inline fuse requirement

If your product is NOT supplied with an inline fuse (whether separately or fitted to the power cable), you MUST fit a suitably-rated inline fuse to your product's red power wire, housed in a waterproof fuse holder.

The illustration below shows the two main types of inline fuse with waterproof holder, for use in marine electronics installations. Fuses in a variety of ratings are widely available at chandleries and marine electrical retailers.

Select one of the following fuse types to protect your product:

[Power connection \(Wireless gateway\)](#)

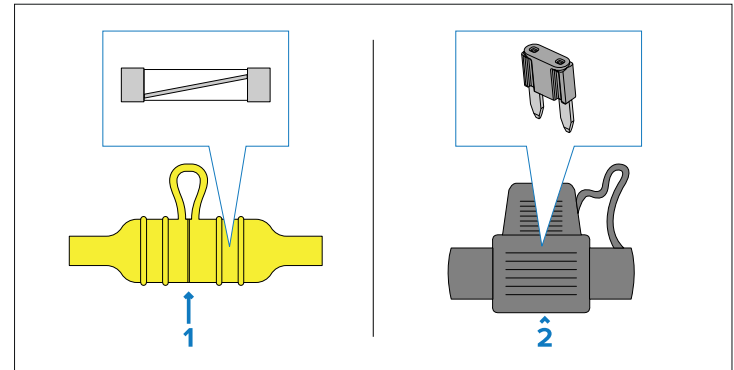

1. Waterproof fuse holder containing a “glass”-type inline fuse.
2. Waterproof fuse holder containing a “blade”-type inline fuse.

Fuse ratings:

- *Voltage rating* — must be equal to or greater than the voltage of your vessel's power supply.
- *Current rating* — refer to the *Inline fuse and thermal breaker rating* section in this document.

Inline fuse and thermal breaker ratings

The SeaTalk NG network's power supply requires a suitably-rated inline fuse or thermal breaker to be fitted.

Inline fuse rating	Thermal breaker rating
5A	3A (refer to note below)

Note:

The suitable fuse rating for the thermal breaker is dependent on:

1. How many devices you have connected to your SeaTalk NG network, and;
2. How many devices are sharing the same thermal breaker that your SeaTalk NG network is connected to.

11.2 12 Volt dc only

This product must **ONLY** be connected to a 12 V dc power source.

11.3 SeaTalk NG power cables

The following SeaTalk NG power cables can be used to connect the backbone to your chosen **12 V dc** power supply:

Direct connection cables



1. Standard (straight) SeaTalk NG power cable, 2 m (6.6 ft) (part number: **A06049**).
2. Elbow (right-angled) SeaTalk NG power cable, 2 m (6.6 ft) (part number: **A06070**).

Wiring

- **+ Red (positive) wire** — connects to the battery or distribution panel positive terminal. A waterproof fuse holder with 5 A inline fuse (not supplied) must be fitted to this red wire.
- **- Black (negative) wire** — connects to battery or distribution panel negative terminal.
- **Drain wire** — connects to the vessel's RF common ground point (if available), or the battery's negative (-) terminal.

Autopilot Control Unit connection cable



1. ACU-Series/SPX-Series autopilot to SeaTalk NG spur cable, 0.3 m (1.0 ft) (part number **R12112**). Connects the course computer to the SeaTalk NG backbone. This connection can also be used to provide 12 V dc power to the SeaTalk NG backbone.

11.4 SeaTalk NG power cable extension

If you need to extend the length of the SeaTalk NG power cable, ensure you observe the following advice:

- Ensure that any extensions of the SeaTalk NG power cable are of a sufficient gauge for the supply voltage, the total current load of the device, and the length of the cable run — as the cable run length increases, the greater the voltage drop will be from one end of the power cable to the other.
- Refer to the following table for typical **minimum** power cable wire gauges:

Cable length in meters (feet)	Wire gauge in AWG (mm ²) for 12 V supply
<8 (<25)	16 (1.31 mm ²)
16 (50)	14 (2.08 mm ²)
24 (75)	12 (3.31 mm ²)
>32 (>100)	10 (5.26 mm ²)

Important:

Be aware that some products in your system (such as sonar modules) can create voltage peaks at certain times, which may impact the voltage available to other products during the peaks.

Important:

To ensure power cables (including any extension) are of a sufficient gauge, ensure that there is a continuous **minimum** voltage of **10.8 V dc** at the end of the SeaTalk NG power cable where it enters the SeaTalk NG backbone, even with a fully flat battery at 11 V dc. (Do not assume that a flat battery is at 0 V dc. Due to the discharge profile and internal chemistry of batteries, the current drops much faster than the voltage. A “fully flat” battery still shows a positive voltage, even if it doesn't have enough current to power your device.)

11.5 SeaTalk NG product loading

The number of products that can be connected to a SeaTalk NG backbone depends on the current draw of each product and the physical length of the backbone cabling.

NMEA 2000 Load Equivalency Numbers (LEN) are used to express the amount of current that is drawn from SeaTalk NG products (**1 LEN = 50 mA**). The LEN for each product can be found in the product's *Technical Specification*.

Products which have a dedicated power supply connection and are connected to the SeaTalk NG backbone will still have an LEN rating. This is because the product's NMEA 2000 / SeaTalk NG internal transceiver will still be powered by the SeaTalk NG backbone.

LENs are used to determine the power connection point for the SeaTalk NG backbone.

11.6 SeaTalk NG power connection point

The point along the backbone where the power connection should be made is based on the length of the backbone.

Note:

- A 12 V dc power supply must be connected to a *white* spur SeaTalk NG connection on the backbone.
- Do NOT connect the power connection to a *blue* SeaTalk NG backbone connector.
- **With the exception of** the iTC-5 and the backbone itself, do NOT connect the power supply directly to a product's *white* SeaTalk NG spur connector.

Small systems

If the backbone length is 60 m (197 ft) or less, the power connection may be made at any point in the backbone.

Large systems

If the backbone length is greater than 60 m (197 ft), the power connection should be made at a point that creates a balanced current draw from each side of the backbone. Load Equivalency Numbers (LEN) are used to determine the power connection point for the system.

Power connection (Wireless gateway)

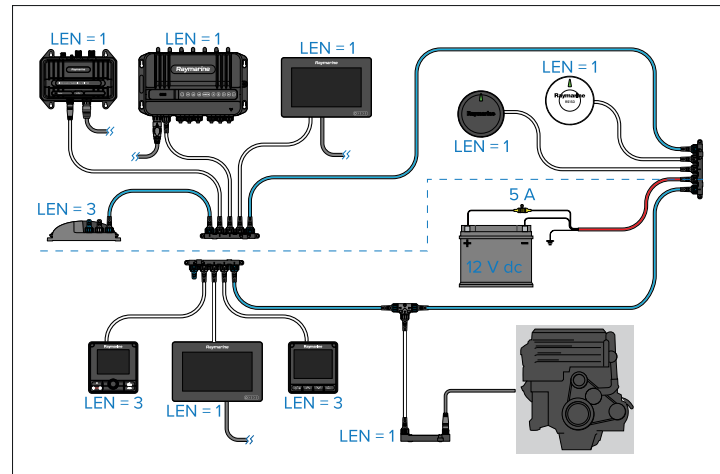

In the example above, the system has an overall LEN of 16, so the optimum connection point would be to have a loading of 8 LEN either side of the connection point.

11.7 SeaTalk NG system loading

The maximum loading (LEN) for a SeaTalk NG system depends on the length of the backbone.

Unbalanced system loading:

- **Backbone Length:** 0 m (0 ft) to 20 m (66 ft) — **Maximum LEN:** 40
- **Backbone Length:** > 20 m (66 ft) to 40 m (131 ft) — **Maximum LEN:** 20
- **Backbone Length:** > 40 m (131 ft) to 60 m (197 ft) — **Maximum LEN:** 14

Balanced system loading:

- **Backbone Length:** 0 m (0 ft) to 60 m (197 ft) — **Maximum LEN:** 100
- **Backbone Length:** > 60 m (197 ft) to 80 m (262 ft) — **Maximum LEN:** 84
- **Backbone Length:** > 80 m (262 ft) to 100 m (328 ft) — **Maximum LEN:** 60
- **Backbone Length:** > 100 m (328 ft) to 120 m (394 ft) — **Maximum LEN:** 50

- **Backbone Length:** > 120 m (394 ft) to 160 m (525 ft) — **Maximum LEN:** 40
- **Backbone Length:** > 160 m (525 ft) to 200 m (656 ft) — **Maximum LEN:** 32

11.8 Power distribution — SeaTalk NG

Recommendations and best practice.

- Only use approved SeaTalk NG power cables. Do NOT use a power cable designed for, or supplied with, a different product.
- See below for more information on implementation for some common power distribution scenarios.

Important:

- When planning and wiring, take into consideration other products in your system, some of which (e.g. sonar modules) may place large power demand peaks on the vessel's electrical system, which may impact the voltage available to other products during the peaks.
- The information provided below is for guidance only, to help protect your product. It covers common vessel power arrangements, but does NOT cover every scenario. If you are unsure how to provide the correct level of protection, please consult an authorized Raymarine dealer or a suitably qualified professional marine electrician.

Implementation — connection to distribution panel (recommended)

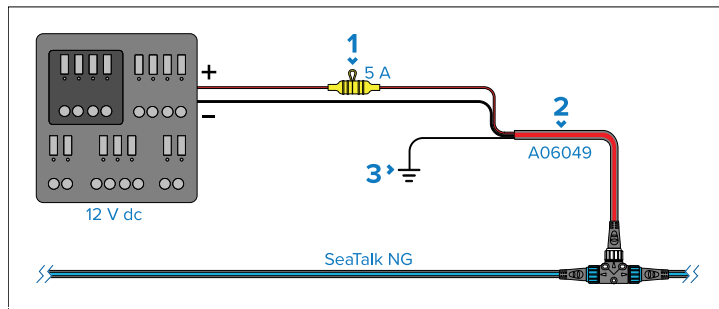

1. Waterproof fuse holder with 5 A inline fuse must be fitted (not supplied).
 2. SeaTalk NG power cable.
 3. RF Ground connection point for drain wire.
- Ideally, the SeaTalk NG power cable should be connected to a suitable breaker or switch on the vessel's distribution panel or factory-fitted power distribution point. It is recommended that a 5 A inline fuse is fitted to the red (positive) wire of the SeaTalk NG power cable.
 - The distribution point should be fed from the vessel's primary power source by 8 AWG (8.36 mm²) cable.
 - Ideally, all equipment should be wired to individual suitably-rated thermal breakers or fuses, with appropriate circuit protection. Where this is not possible and more than one item of equipment shares a breaker, use individual in-line fuses for each power circuit to provide the necessary protection.

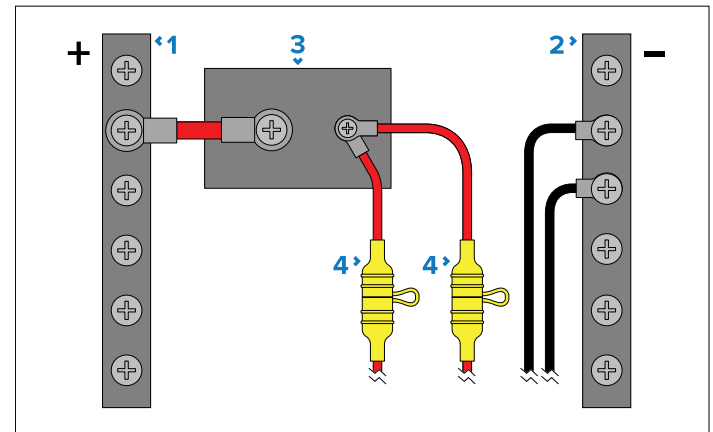

1. Positive (+) bar
2. Negative (-) bar
3. Circuit breaker
4. Waterproof fuse holder with 5 A inline fuse must be fitted (not supplied).

Important:

Observe the recommended fuse / breaker ratings provided in the product's documentation, however be aware that the suitable fuse / breaker rating is dependent on the number of devices being connected.

Implementation — direct connection to battery

- Where connection to a power distribution panel is not possible, the power cable may be connected to the vessel's battery.
- You **MUST** fit a 5 A inline fuse between the red wire and the battery's positive terminal.
- If you need to extend the length of the power cable, ensure you use suitably rated cable and that sufficient power (12 V dc) is available at the SeaTalk NG backbone's power connection.

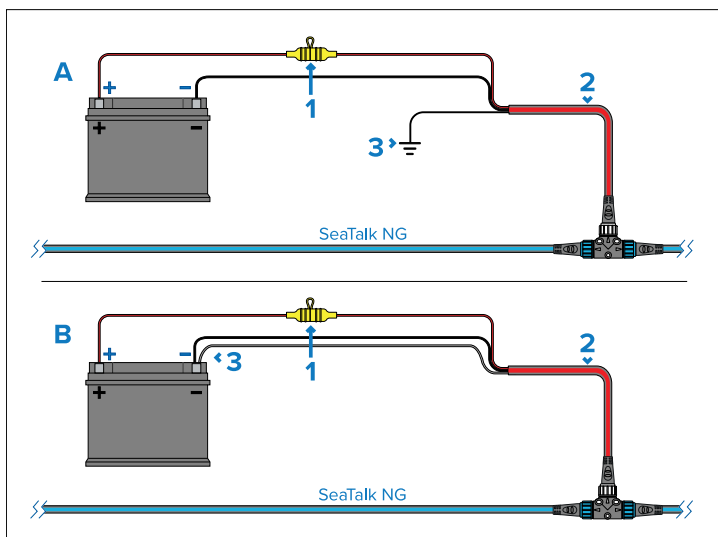

1. Waterproof fuse holder with 5 A inline fuse must be fitted (not supplied).
2. SeaTalk NG power cable.
3. Connection point for drain wire.

Battery connection scenario A:

Power connection (Wireless gateway)

Suitable for a vessel with a common RF ground point. In this scenario, the power cable's drain wire should be connected to the vessel's common RF ground point.

Battery connection scenario B:

Suitable for a vessel without a common RF ground point. In this scenario the power cable's drain wire should be connected directly to the battery's negative terminal.

SeaTalk NG Power cable extension

If you need to extend the length of the SeaTalk NG power cable, ensure you use suitably-rated cable, and that sufficient power is available at the SeaTalk NG backbone's power connection point:

- For power cable extensions, a **minimum** wire gauge of 16 AWG (1.31 mm²) is recommended. For cable runs longer than 15 m (49.2 ft), you may need to consider a thicker wire gauge (e.g. 14 AWG (2.08 mm²), or 12 AWG (3.31 mm²).
- To ensure power cables (including any extension) are of a sufficient gauge, ensure that there is a continuous **minimum** voltage of **10.8 V dc** at the end of the cable where it enters the product's power connector, even with a fully flat battery at 11 V dc. (Do not assume that a flat battery is at 0 V dc. Due to the discharge profile and internal chemistry of batteries, the current drops much faster than the voltage. A "fully flat" battery still shows a positive voltage, even if it doesn't have enough current to power your device.)

Important:

Be aware that some products in your system (such as sonar modules) can create voltage peaks at certain times, which may impact the voltage available to other products during the peaks.

More information

It is recommended that best practice is observed in all vessel electrical installations, as detailed in the following standards:

- BMEA Code of Practice for Electrical and Electronic Installations in Boats
- NMEA 0400 Installation Standard
- ISO 13297: Small craft — Electrical systems — Alternating and direct current installations

- ISO 10133: Small craft — Electrical systems — Extra-low-voltage d.c. installations
- ABYC E-11 AC & DC Electrical Systems on Boats
- ABYC A-31 Battery chargers and Inverters
- ABYC TE-4 Lightning Protection



Warning: 12 Volt dc only

This product must **ONLY** be connected to a 12 V dc power source.



Warning: Product grounding

Before applying power to this product, it **MUST** be correctly grounded, in accordance with the instructions provided.



Warning: Positive ground systems

Do **NOT** connect this unit to a system which has positive grounding.

11.9 Power connection via Autopilot Control Unit (ACU-Series)

The SeaTalk NG backbone can be supplied 12 V dc power from a compatible Raymarine Autopilot Control Unit (ACU-Series).

Important:

The SeaTalk NG backbone must have a single power supply connection. If your SeaTalk NG backbone is supplied power directly from a battery or distribution panel, then you must ensure that the SeaTalk NG power switch on your ACU-Series is switched Off.

Note:

ACU-100, ACU-150 and SPX-5 autopilot control units cannot supply power to the SeaTalk NG backbone.

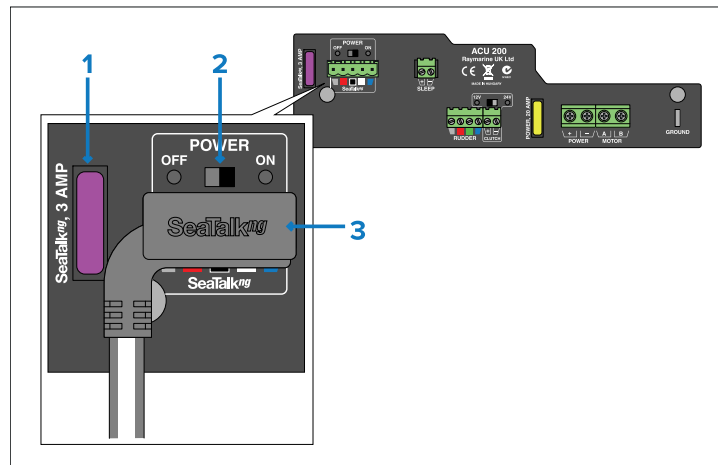

1. Fuse for SeaTalk NG power supply.
2. Power switch for SeaTalk NG power supply:
 - a. Select the *[OFF]* position if your SeaTalk NG backbone is supplied power directly from a battery or distribution panel.
 - b. Select the *[ON]* position if your SeaTalk NG backbone is supplied power by the ACU-Series.
3. ACU-Series/SPX-Series autopilot to SeaTalk NG spur cable (part number: R12112).

CHAPTER 12: OPERATIONS

CHAPTER CONTENTS

- 12.1 Inserting batteries — page 48
- 12.2 Connecting the lanyard — page 48
- 12.3 Using the cradle — page 48
- 12.4 Controls — page 49
- 12.5 Operation instructions — page 50

12.1 Inserting batteries

Use the supplied AA batteries to power the remote.

Before inserting the supplied batteries remove any protective packaging.

Note:

- Only use AA batteries to power the remote.
- Alkaline, Lithium or rechargeable batteries are recommended.
- It is also recommended that you purchase a spare pair of suitable AA batteries to limit any operational interruptions due to depleted batteries.

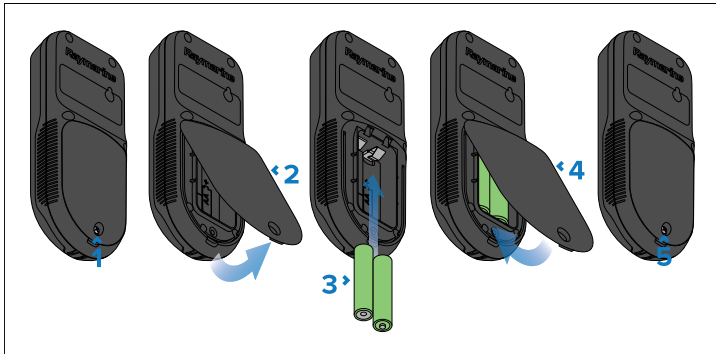

1. Unscrew the captive battery cover screw.
2. Remove the battery cover by pivoting the bottom of the cover away from the remote control.
3. Ensuring correct orientation, insert the new batteries.
Correct battery orientation is indicated in the battery compartment, and is viewable when no batteries are fitted.
4. Replace the battery cover by inserting the top lugs into the remote control at a slight angle, and then push the bottom of the cover to its closed position.
5. Re-tighten the battery cover screw.

12.2 Connecting the lanyard

The supplied lanyard should be connected to the remote control.

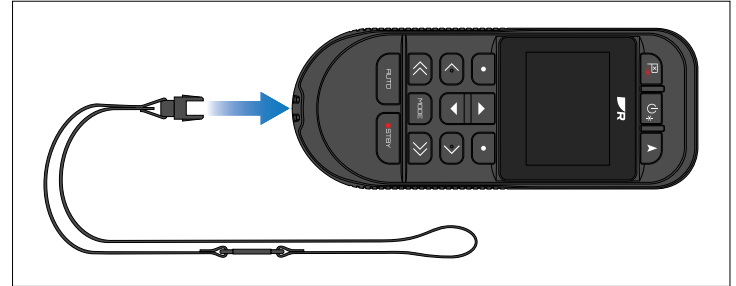

1. Insert the end of the Lanyard into the holes located on the bottom of the remote control.

12.3 Using the cradle

When the remote is not in use it should be inserted in its cradle.

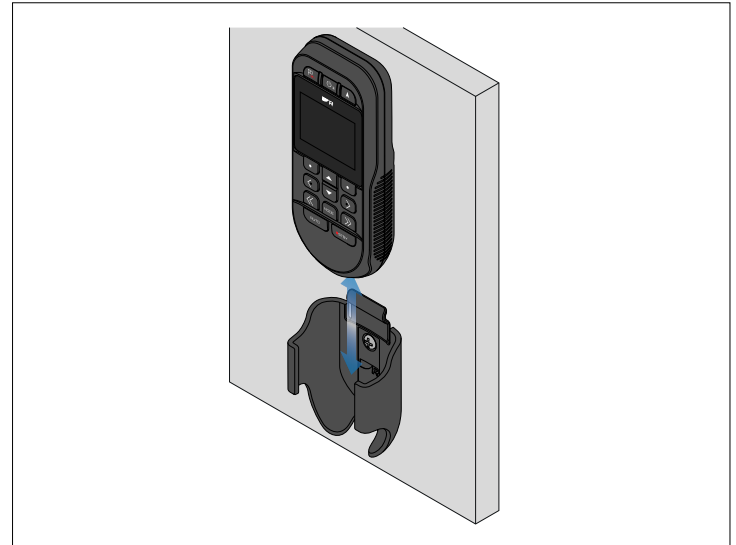

- **Inserting the remote:** Gently **push** the remote in a **downward** motion into the cradle, ensuring that the remote is pushed down

fully into the cradle. The remote remains fully operational while in its cradle.

- **Removing the remote:** Gently **pull** the remote in an **upward** motion out of the cradle.

12.4 Controls

The RCU-1 has physical buttons which are used to interact with the remote's user interface. The details below describe the buttons and their functions.

General usage:

- Buttons 2, and 7 to 13 are used to control the autopilot.
- Buttons 3 to 6 are used to control the remote's user interface.



Description	
1	<i>[Waypoint / MOB]</i> — Press momentarily to place a waypoint at your vessel's location. A long press activates the Man Overboard (MOB) alarm.
2	<i>[Point and Go]</i> — Press to capture the remote's current bearing and place a <i>[GoTo]</i> at a defined distance.

Description	
3	<i>[Power]</i> <ul style="list-style-type: none"> • Press to power on. • When powered on, press to open the <i>[Brightness]</i> page. With the <i>[Brightness]</i> page displayed, pressing the <i>[Power]</i> button again increases the brightness in increments. • Press and hold to power off.
4	<i>[Up] / [Down]</i> — Use these buttons to move through menus, modify numeric settings, or adjust brightness from the Brightness page.
5	<i>[Left Softkey]</i> — The button's action is context-dependent, and is identified on the screen above the button.
6	<i>[Right Softkey]</i> — The button's action is context-dependent, and is identified on the screen above the button.
7	<i>[<]</i> (Left 1°) — Change Heading, Rudder angle, or Wind direction offset to port by 1° (one degree).
8	<i>[>]</i> (Right 1°) — Change Heading, Rudder angle, or Wind direction offset to starboard by 1° (one degree).
9	<i>[<<]</i> (Left 5° / 10°) <ul style="list-style-type: none"> • Change Heading, or Wind direction offset to port by 10° (ten degrees). • Increase rudder angle to port by 5° (five degrees)
10	<i>[>>]</i> (Right 5° / 10°) <ul style="list-style-type: none"> • Change Heading, or Wind direction offset to starboard by 10° (ten degrees). • Increase rudder angle to starboard by 5° (five degrees)
11	<i>[AUTO]</i> — Press to engage the autopilot in <i>[Steer to Heading mode]</i> .
12	<i>[STBY]</i> — Press to disengage the autopilot.
13	<i>[MODE]</i> — Press to open the autopilot modes menu.

12.5 Operation instructions

For detailed operation instructions, refer to the dedicated *RCU-1 Autopilot Remote Control Operation Instructions* (Document number: 81426): www.bit.ly/RCU-1-docs

CHAPTER 13: TROUBLESHOOTING

CHAPTER CONTENTS

- 13.1 Troubleshooting — page 52
- 13.2 Wireless troubleshooting — page 52
- 13.3 LED diagnostic guidance — page 54
- 13.4 WG-1 LED diagnostics — page 55

13.1 Troubleshooting

The troubleshooting section provides possible causes and the corrective action required for common problems that are associated with the installation and operation of your product.

Before packing and shipping, all products are subjected to comprehensive testing and quality assurance programs. If you do experience problems with your product, this section will help you to diagnose and correct problems to restore normal operation.

If after referring to this section you are still having problems with your product, please refer to the *Technical support and servicing* section of this manual for useful links and contact details.

13.2 Wireless troubleshooting

Before troubleshooting problems with your wireless connection, ensure that you have followed the location requirements guidance provided in the relevant installation instructions and performed a power cycle/reboot of the devices you are experiencing problems with.

Device(s) not connected to the wireless gateway

Possible causes	Possible solutions
Device not powered.	Ensure that you have correctly followed the power connection information specified in the documentation which is supplied with your device.
Device out of range.	Wireless performance degrades over distance, so products farther away will receive less network bandwidth. Products installed close to their maximum wireless range will experience slow connection speeds, signal drop outs or no connection at all. In order to maintain a reliable connection, ensure that the distance between wireless products is kept to a minimum. For more information, refer to: p.24 – Location requirements

Possible causes	Possible solutions
Device signal is blocked.	<ul style="list-style-type: none">• Bulkheads, decks and other heavy structure can degrade and even block the wireless signal. Depending on the material and its thickness, it may not always be possible to pass a wireless signal through certain structures.• Crew members (especially when wet) can also be obstructive to wireless signals, if their bodies pass through the signal area.
Device software incompatibility.	Ensure both devices are running the latest available software.

Unable to pair with a device

Possible causes	Possible solutions
Device out of range.	Wireless performance degrades over distance, so products farther away will receive less network bandwidth. Products installed close to their maximum wireless range will experience slow connection speeds, signal drop outs or no connection at all. In order to maintain a reliable connection, ensure that the distance between wireless products is kept to a minimum. For more information, refer to: p.24 – Location requirements
Device signal is blocked.	<ul style="list-style-type: none">• Bulkheads, decks and other heavy structure can degrade and even block the wireless signal. Depending on the material and its thickness, it may not always be possible to pass a wireless signal through certain structures.• Crew members (especially when wet) can also be obstructive to wireless signals, if their bodies pass through the signal area.
Device software incompatibility.	Ensure both devices are running the latest available software.

Possible causes	Possible solutions
Incorrect password.	Ensure that you have enter the password correctly before attempting to retry and connect.
Connection time-out.	Before attempting to retry and connect, ensure that your device has been correctly installed in accordance with the guidance provided throughout the following section: p.24 — Location requirements

Connection extremely slow and or keeps dropping out

Possible causes	Possible solutions
Device out of range.	Wireless performance degrades over distance, so products farther away will receive less network bandwidth. Products installed close to their maximum wireless range will experience slow connection speeds, signal drop outs or no connection at all. In order to maintain a reliable connection, ensure that the distance between wireless products is kept to a minimum. For more information, refer to: p.24 — Location requirements
Device signal is blocked.	<ul style="list-style-type: none"> • Bulkheads, decks and other heavy structure can degrade and even block the wireless signal. Depending on the material and its thickness, it may not always be possible to pass a wireless signal through certain structures. • Crew members (especially when wet) can also be obstructive to wireless signals, if their bodies pass through the signal area.

Possible causes	Possible solutions
Interference being caused by other wireless-enabled devices.	<p>Wireless products should be installed at least 1 m (3.28 ft) away from:</p> <ul style="list-style-type: none"> • Other wireless-enabled products. • Transmitting products that send wireless signals in the same frequency range. • Other electrical, electronic or electromagnetic equipment that may generate interference.
Interference caused by other devices that use the 2.4 GHz frequency See list below of some common devices that use the 2.4 GHz frequency:	<p>Wireless products should be installed at least 1 m (3.28 ft) away from:</p> <ul style="list-style-type: none"> • Other wireless-enabled products. • Transmitting products that send wireless signals in the same frequency range. • Other electrical, electronic or electromagnetic equipment that may generate interference. <ul style="list-style-type: none"> • Microwave ovens • Fluorescent lighting • Cordless phones / baby monitors • Motion sensors

Possible causes	Possible solutions
Interference caused by electrical and electronic devices and associated cabling could generate an electromagnetic field which may interfere with the wireless signal.	<p>Wireless products should be installed at least 1 m (3.28 ft) away from:</p> <ul style="list-style-type: none"> • Other wireless-enabled products. • Transmitting products that send wireless signals in the same frequency range. • Other electrical, electronic or electromagnetic equipment that may generate interference.
Interference from devices on other vessels. When in close proximity to other vessels, many other wireless signals may be present; for example, when moored up in a marina.	If possible, move your vessel to a location with less wireless traffic.

Network connection established but no data received

Possible causes	Possible solutions
Device software incompatibility.	Ensure both devices are running the latest available software.
Device fault.	<ol style="list-style-type: none"> 1. Try updating software to a later version, or try reinstalling the current software. 2. Contact technical support for further assistance.

13.3 LED diagnostic guidance

Your product has diagnostic LEDs which can be used to identify the unit's status and to help troubleshoot any potential issues that may occur.

The following section provides two basic examples of how to interpret the LED diagnostic patterns included in this publication.

Example solid LED diagnostic pattern:

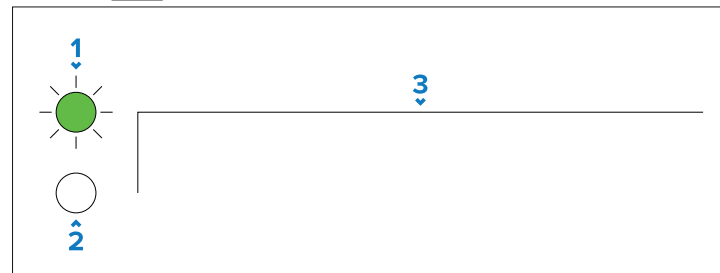

1. **LED ON** — Indicates the color assigned to the unit's diagnostic LED, and confirms that the diagnostic LED is active (switched **on**).
2. **LED OFF** — Indicates that the unit's diagnostic LED is inactive (switched **off**).
3. **Diagnostic pattern** — Indicates a diagnostic pattern based on the number and duration of *peaks* (indicating LED is switched **on**) and *troughs* (indicating LED is switched **off**) generated within the duration of the diagnostic pattern. In the example shown above, a continuous peak occurs, indicating that the LED is permanently **on**.

Example flashing LED diagnostic pattern:

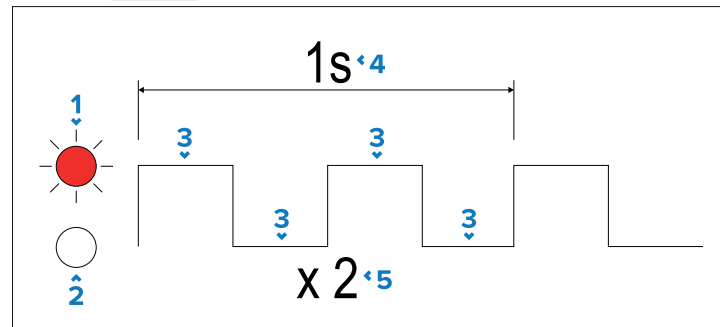



1. **LED ON** — Indicates the color assigned to the unit's diagnostic LED, and confirms that the diagnostic LED is active (switched **on**).
2. **LED OFF** — Indicates that the unit's diagnostic LED is inactive (switched **off**).
3. **Diagnostic pattern** — Indicates a diagnostic pattern based on the number and duration of *peaks* (indicating LED is switched

on) and *troughs* (indicating LED is switched **off**) generated within the duration of the diagnostic pattern. In the example shown above, a peak followed by a trough occurs and then repeats again, indicating that the LED flashes twice within a period of one second.

4. **Diagnostic pattern duration** — Indicates the total duration of the diagnostic pattern.
5. **Diagnostic pattern flash total** — Indicates the total number of flashes that occur within the diagnostic pattern.

13.4 WG-1 LED diagnostics

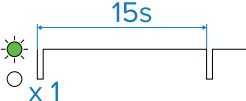
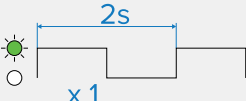
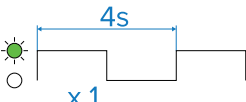
The wireless gateway has diagnostic LEDs on the front of the unit. These LEDs are used to identify the unit's status, and can be used for troubleshooting.

LED indication	LED status and possible solutions
	<p>(Green) Powered up / Ok</p> <ul style="list-style-type: none"> Normal operation — no user action is required.
	<p>(Green) No wind vane connected / Wind vane connecting</p> <ul style="list-style-type: none"> Check the relevant product, network cabling and connections for signs of damage or corrosion, and replace if necessary.
	<p>(Green) Update in progress</p> <ul style="list-style-type: none"> Normal operation — no user action is required.
	<p>(Green) Gateway powering on</p> <ul style="list-style-type: none"> Normal operation — no user action is required.

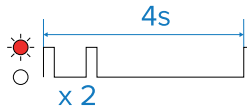
LED indication	LED status and possible solutions
	<p>(Red) CAN not connected</p> <ul style="list-style-type: none"> Check the relevant product, network cabling and connections for signs of damage or corrosion, and replace if necessary. Consider contacting your local dealer or Raymarine® Product Support.

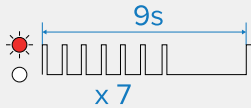
LED indication**LED status and possible solutions**

(Red) CAN Fault

- Check the relevant product, network cabling and connections for signs of damage or corrosion, and replace if necessary.
- Consider contacting your local dealer or Raymarine® Product Support.



(No color) No power

1. Check the vessel's battery voltage, the condition of the battery terminals and power supply cables, ensuring connections are secure, clean and free from corrosion; replace if necessary.
2. Check the power supply cable and connectors for signs of damage or corrosion; replace if necessary.
3. Check that the power cable connector is fully inserted into the unit and locked in position.
4. With the unit turned on, try flexing the power cable near to the connector to see if this causes the unit to re-start/lose power; replace if necessary.
5. With the product under load, using a multi-meter, check for high voltage drop across all connectors / fuses etc, and replace if necessary.

CHAPTER 14: MAINTENANCE

CHAPTER CONTENTS

- 14.1 Routine equipment checks — page 58
- 14.2 Cleaning the unit — page 58
- 14.3 Replacing the batteries — page 58

14.1 Routine equipment checks

It is recommended that you perform the following routine checks, on a regular basis, to ensure the correct and reliable operation of your equipment:

- Examine all cables for signs of damage or wear and tear.
- Check that all cables are securely connected.

Caution: Service and maintenance

This product contains no user serviceable components. Please refer all maintenance and repair to authorized Raymarine dealers. Unauthorized repair may affect your warranty.

14.2 Cleaning the unit

The remote should only be cleaned with the battery cover closed.

1. Power the unit off.
2. Wipe the unit's enclosure with a clean, lint-free microfibre cloth.
3. If necessary, use a mild detergent to remove grease marks from the unit's enclosure.
4. Rinse the screen with fresh water to remove all dirt particles and salt deposits.
5. Allow the screen to dry naturally.
6. If any smears remain, very gently wipe the screen with a clean, lint free microfibre cloth.

14.3 Replacing the batteries

The AA batteries can be replaced by removing the rear battery cover.

Note:

Only use AA batteries to power the remote.

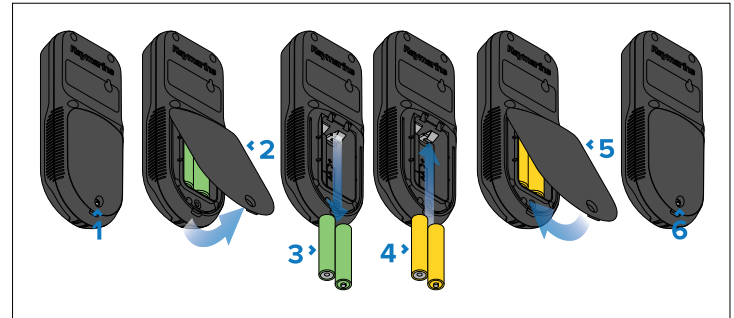

1. Unscrew the captive battery cover screw.
2. Remove the battery cover by pivoting the bottom away from the remote control.
3. Remove the batteries.
4. Ensuring correct orientation, insert the new batteries.
Battery orientation is indicated in the battery compartment and is viewable when no batteries are present.
5. Replace the battery cover by inserting the top lugs into the remote control at a slight angle, and then push the bottom of the cover until it is fully inserted.
6. Re-tighten the battery cover screw.

Battery disposal

Consumers in European Union (EU) Member State regions are required to dispose of the battery (or batteries) included with this product in accordance with the EU Battery Directive (2006/66/EC).

The Battery Directive requires the proper waste management of batteries, including their recycling, collection, take-back programs, and disposal. The purpose of the Directive is to ensure the appropriate management of waste batteries which contain materials and chemicals that may be hazardous and present a risk to human health and / or the environment, when not handled correctly.

Local authorities in many regions have established collection schemes under which residents can dispose of waste batteries at a recycling center or other collection point. For a list of relevant websites for each region, visit: www.bit.ly/rym-recycling

CHAPTER 15: TECHNICAL SUPPORT

CHAPTER CONTENTS

- 15.1 Raymarine technical support and servicing — page 60
- 15.2 Learning resources — page 61
- 15.3 Viewing product information — page 61
- 15.4 Viewing product information from a chartplotter — page 62

15.1 Raymarine technical support and servicing

Raymarine provides a comprehensive product support service, as well as warranty, service, and repairs. You can access these services through the Raymarine website, telephone, and e-mail.

Product information

If you need to request service or support, please have the following information to hand:

- Product name.
- Product identity.
- Serial number.
- Software application version.
- System diagrams.

Servicing and warranty

Raymarine offers dedicated service departments for warranty, service, and repairs.

Visit the Raymarine website to **read the latest warranty policy**, and **register** your product's warranty online:

- www.bit.ly/rym-warranty

United Kingdom (UK), EMEA, and Asia Pacific:

- Web: www.bit.ly/rym-service
- Tel: +44 (0)1329 246 932

United States (US):

- Web: www.bit.ly/rym-service
- Tel: +1 (603) 324 7900

Web support

Please visit the “Support” area of the Raymarine website for:

- **Manuals and Documents** — www.bit.ly/rym-docs
- **Technical support forum** — www.bit.ly/rym-support
- **Software updates** — www.bit.ly/rym-software

Telephone and online support

Region	Contact details
All regions	Online support: www.bit.ly/rym-support
United Kingdom (UK) and EMEA	Telephone: +44 (0)1329 246 777 Address: Marine House, Cartwright Drive, Fareham, PO15 5RJ, UK.
United States (US)	Telephone: Tel: +1 (603) 324 7900 (Toll-free: +800 539 5539) Address: 110 Lowell Road, Hudson, NH 03051, USA.
Australia and New Zealand (Raymarine subsidiary)	Telephone: +61 2 8977 0300 Address: Suite 1.01, 26 Rodborough Road, Frenchs Forest, NSW, 2086, Australia.
France (Raymarine subsidiary)	Telephone: +33 (0)1 46 49 72 30 Address: 35 avenue Michel Crépeau, 17000 La Rochelle - France.
Germany (Raymarine subsidiary)	Telephone: +49 40 237 808 0 Address: Atlantic-Haus, Zirkusweg 1, 20359 Hamburg.
Italy (Raymarine subsidiary)	Telephone: +39 02 9945 1001 Address: Via L. Manara 2, 20812 Limbiate (MB), Italy.
Spain (Authorized Raymarine distributor)	Telephone: +34 96 2965 102 Email: sat@azimut.es
Netherlands / Benelux (Authorized Raymarine distributor)	Telephone: +31 (0)26 3614 905 Address: Florijnweg 21G, 6883 JN VELD, Nederland.

Region	Contact details
Sweden (Raymarine subsidiary)	Telephone: +46 (0)317 633 670 Address: Bolshedens Industriväg 18, 427 50 Billdal, Sweden.
Finland (Raymarine subsidiary)	Telephone: +358 (0)207 619 937 Address: Suomalaistentie 1-3, 02270 Espoo, Finland.
Norway (Raymarine subsidiary)	Telephone: +47 692 64 600 Address: Årvollskogen 30, 1529 Moss, Norway.
Denmark (Raymarine subsidiary)	Telephone: +45 437 164 64 Address: Centervej 7, 4600 Køge, Denmark.
Russia (Distributor)	Telephone: Tel: +7 495 788 0508 Email: info@mikstmarine.ru

15.2 Learning resources

Raymarine has produced a range of learning resources to help you get the most out of your products.

Video tutorials

Raymarine official channel on YouTube

- <http://www.youtube.com/user/RaymarineInc>

Training courses

Raymarine regularly runs a range of in-depth training courses to help you make the most of your products. Visit the Training section of the Raymarine website for more information:

- www.bit.ly/rym-training

Technical support forum

You can use the Technical support forum to ask a technical question about a Raymarine product or to find out how other customers are

[Technical support](#)

using their Raymarine equipment. The resource is regularly updated with contributions from Raymarine customers and staff:

- www.bit.ly/rym-support

15.3 Viewing product information

Use the *[About this device option]* in the *[Settings]* menu to view hardware and software information about your product.



1. Press the *[Menu]* button.
2. Scroll to the *[Settings]* menu and press the *[Select]* button.
3. Scroll to the *[About this device]* menu and press the *[Select]* button.
4. Scroll down to view further details.

15.4 Viewing product information from a chartplotter

Hardware and software information related to your product can be viewed from a compatible chartplotter running LightHouse 4.

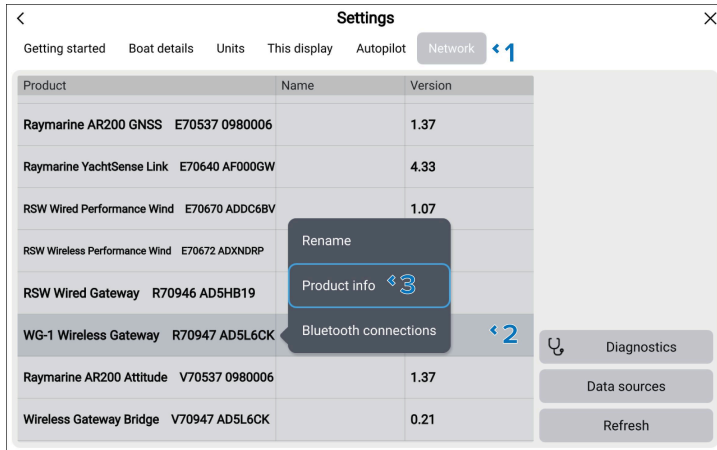

From the [*Homescreen* > *Settings*] menu:

1. Select the [*Network*] tab.
2. Select your device from the network list.

The software version for your device will be listed in the [Version] column of the network list.

3. Select [*Product info*] from the pop-over options.

The product information details for the selected device will be displayed.

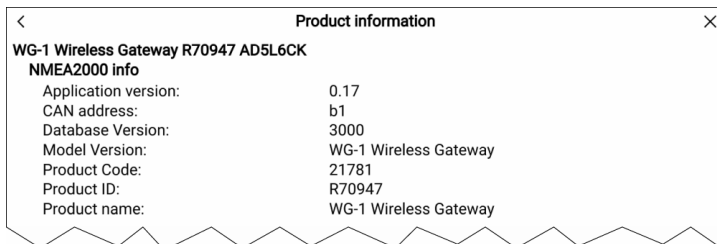

CHAPTER 16: TECHNICAL SPECIFICATION — AUTOPILOT REMOTE CONTROL

CHAPTER CONTENTS

- 16.1 Physical specification — page 64
- 16.2 Battery specification — page 64
- 16.3 Environmental specification — page 64
- 16.4 AHRS specification — page 64
- 16.5 Bluetooth specification — page 64
- 16.6 Conformance specification — page 65
- 16.7 Product markings — page 65

16.1 Physical specification

Specification	
Height (handset only):	150.87 mm (5.94 in)
Width (handset only):	59.83 mm (2.36 in)
Depth (handset only):	31.51 mm (1.24 in)
Product weight (Remote and batteries):	190 g (6.70 oz)

16.2 Battery specification

The specification below should be referred to when sourcing replacement batteries for the remote.

Specification	
Size:	<ul style="list-style-type: none">• AA
Supported types:	<p>The remote is supplied with 2x AA Alkaline batteries. It is recommended that one of the following types of replacement AA batteries are used:</p> <ul style="list-style-type: none">• Alkaline• Lithium• Rechargeable
	<div style="border: 1px solid black; padding: 5px;">Note: Do not mix different battery types or brands.</div>
Battery life expectancy:	<ul style="list-style-type: none">• In use: 30 days• Storage: 365 days

Note:	Quoted battery life expectancy figures are for average use using the supplied batteries. Actual battery life will differ, depending on usage, battery type, and ambient temperature.
--------------	--

16.3 Environmental specification

Specification	
Operating temperature range:	-25° C (-13° F) to + 55° C (131° F)
Storage temperature range:	-30°C (-22° F) to + 70° C (158° F)
Humidity:	up to 95% @ 40° C (104° F)
Water ingress protection:	IP67
Installation location:	<ul style="list-style-type: none">• Above decks• Below decks

16.4 AHRS specification

Specification	
AHRS:	<ul style="list-style-type: none">• 3-Axis Accelerometer• 3-Axis Magnetometer• 3-Axis Gyroscope
Magnetic compass accuracy:	<ul style="list-style-type: none">• Static: $\pm 1^\circ$ RMS• Dynamic: $\pm 5^\circ$ RMS
Pitch, Roll and Yaw accuracy:	$\pm 1^\circ$
Heading, Pitch, Roll, and Rate-of-Turn update rate:	10 Hz

16.5 Bluetooth specification

Specification	
Bluetooth Version:	5.1
Connection range:	Up to 30 m (98.43 ft) with clear line of sight

16.6 Conformance specification

This product is compliant or approved to the following standards or by the listed entities.

Specification	
UK:	<ul style="list-style-type: none">• SI 2016:1091: Electromagnetic Compatibility (EMC) Regulations 2016• SI 2017:1206: The Radio Equipment Regulations 2017• SI 2023:1542: Battery Regulations• SI 2014:1638: The Restriction of the Use of Certain Hazardous Substances (RoHS) in Electrical and Electronic Equipment Regulations 2012• SI 2013:3113 The Waste Electrical and Electronic Equipment (WEEE) Regulations 2013
EU & EFTA:	<ul style="list-style-type: none">• Directive 2014/30/EC: Electromagnetic Compatibility (EMC) directive• Directive 2014/53/EU: Radio Equipment Directive (RED)• Directive 2023/66/EC: Batteries Directive• Directive 2002/95/EC: Restriction of the use of certain hazardous substances (RoHS) in electrical and electronic equipment directive• Directive 2002/96/EC: Waste Electrical and Electronic Equipment (WEEE) directive
USA:	<ul style="list-style-type: none">• CFR 47 Part 2. 1093: Radiofrequency radiation exposure evaluation: portable devices• CFR 47 Part 15 Subpart C-Intentional Radiators

Specification	
Canada:	<ul style="list-style-type: none">• ISED RSS-Gen: General Requirements for Compliance of Radio Apparatus• ISED RSS-102: Radio Frequency (RF) Exposure Compliance of Radio communication Apparatus (All Frequency Bands)• ISED RSS-247: Digital Transmission Systems (DTs), Frequency Hopping Systems (FHSs) and License-Exempt Local Area Network (LE-LAN) Devices
Taiwan:	<ul style="list-style-type: none">• NCC 低功率射頻器材技術規範(LP0002) 113年2月6日 ANSI C63.10: 2013

16.7 Product markings

The product includes the following approval / compliance markings and/or IDs.

Product markings:	
UK	<ul style="list-style-type: none">• UKCA
EU/EFTA	<ul style="list-style-type: none">• CE• WEEE
USA:	<ul style="list-style-type: none">• FCC
Canada:	<ul style="list-style-type: none">• ISED
Australia / New Zealand	<ul style="list-style-type: none">• Compliance tick mark

CHAPTER 17: TECHNICAL SPECIFICATION — WIRELESS GATEWAY

CHAPTER CONTENTS

- 17.1 Physical specification — page 67
- 17.2 Power specification — page 67
- 17.3 Environmental specification — page 67
- 17.4 Bluetooth specification — page 67
- 17.5 Conformance specification — page 67
- 17.6 Product markings — page 68

17.1 Physical specification

Specification	
Diameter:	108.48 mm (4.27 in)
Height:	26.61 mm (1.05 in)
Product weight (gateway only):	129 g (4.55 oz)

17.2 Power specification

Specification	
Nominal supply voltage:	12 V dc (Supplied by the SeaTalk NG network.)
Operating voltage range:	9 V dc to 16 V dc (protected up to 32 V dc)
Power consumption:	30 mA Max.
LEN (Load Equivalency Rating):	1

17.3 Environmental specification

Specification	
Operating temperature range:	-25 °C to +55 °C (-13 °F to 131 °F)
Storage temperature range:	-25 °C to +70 °C (-13 °F to 158 °F)
Relative humidity:	93%
Water ingress protection:	IPx6, IPx7

17.4 Bluetooth specification

Specification	
Bluetooth Version:	5.1
Connection range:	Up to 30 m (98.43 ft) with clear line of sight

17.5 Conformance specification

This product is compliant or approved to the following standards or by the listed entities.

Specification	
UK:	<ul style="list-style-type: none">• SI 2016:1091: Electromagnetic Compatibility (EMC) Regulations 2016• SI 2017:1206: The Radio Equipment Regulations 2017• SI 2014:1638: The Restriction of the Use of Certain Hazardous Substances (RoHS) in Electrical and Electronic Equipment Regulations 2012• SI 2013:3113 The Waste Electrical and Electronic Equipment (WEEE) Regulations 2013• Product Security And Telecommunications Infrastructure (PSTI) Act 2022
EU & EFTA:	<ul style="list-style-type: none">• Directive 2014/30/EC: Electromagnetic Compatibility (EMC) directive• Directive 2014/53/EU: Radio Equipment Directive (RED)• Directive 2002/95/EC: Restriction of the use of certain hazardous substances (RoHS) in electrical and electronic equipment directive• Directive 2002/96/EC: Waste Electrical and Electronic Equipment (WEEE) directive

Specification

- | | |
|----------------|--|
| USA: | <ul style="list-style-type: none">• CFR 47 Part 15, 1093: Radio Frequency devices |
| Canada: | <ul style="list-style-type: none">• ISED RSS-210: Licence-Exempt Radio Apparatus: Category I Equipment |
| Taiwan: | <ul style="list-style-type: none">• NCC |
-

17.6 Product markings

The product includes the following approval / compliance markings and/or IDs.

Product markings:

- | | |
|--------------------------------|--|
| UK | <ul style="list-style-type: none">• UKCA |
| EU/EFTA | <ul style="list-style-type: none">• CE• WEEE |
| USA: | <ul style="list-style-type: none">• FCC |
| Canada: | <ul style="list-style-type: none">• ISED |
| Australia / New Zealand | <ul style="list-style-type: none">• Compliance tick mark |
-

CHAPTER 18: SPARES AND ACCESSORIES

CHAPTER CONTENTS

- 18.1 Spares — Autopilot remote control — page 70
- 18.2 Accessories — Wireless gateway — page 70
- 18.3 SeaTalk NG cables and accessories — page 70

18.1 Spares — Autopilot remote control

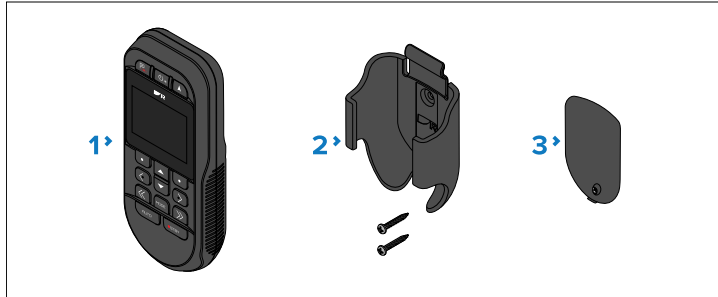

Part number	Description
A80835	Replacement RCU-1 Autopilot remote control.
R71016	Replacement mounting cradle with fixings.
R71017	Replacement battery cover.

18.2 Accessories — Wireless gateway

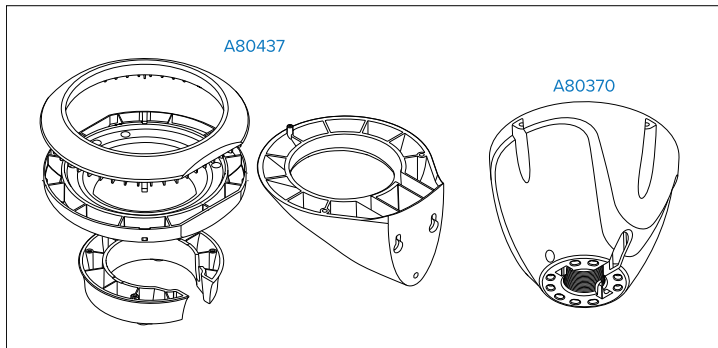

Part number	Description
A80437	Deck mounting (Clamshell / Riser) kit.
A80370	Pole / rail mounting adaptor kit.

18.3 SeaTalk NG cables and accessories

SeaTalk NG cables and accessories for use with compatible products.

SeaTalk NG kits

SeaTalk NG kits enable you to create a simple SeaTalk NG backbone. **Starter kit (part number: T70134)** consists of:

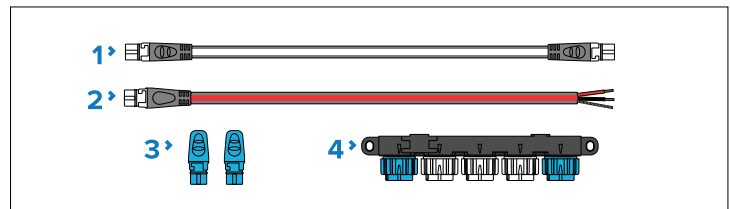

- 1 x Spur cable 3 m (9.8 ft) (part number: **A06040**). Used to connect device to the SeaTalk NG backbone.
- 1 x Power cable 2 m (6.6 ft) (part number: **A06049**). Used to provide 12 V dc power to the SeaTalk NG backbone.
- 2 x Backbone terminators (part number: **A06031**). Terminators must be fitted to both ends of the SeaTalk NG backbone.
- 1 x 5-Way connector (part number: **A06064**). Each connector block allows connection of up to 3 SeaTalk NG devices. Multiple connector blocks can be 'daisy chained' together.

Backbone kit (part number: A25062) consists of:

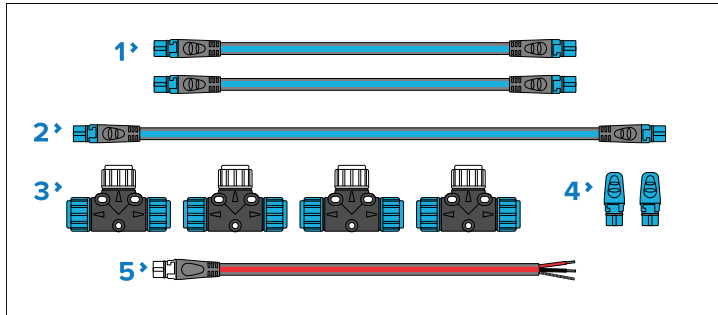

- 2 x Backbone cables 5 m (16.4 ft) (part number: **A06036**). Used to create and extend the SeaTalk NG backbone.
- 1 x Backbone cable 20 m (65.6 ft) (part number: **A06037**). Used to create and extend the SeaTalk NG backbone.
- 4 x T-piece (part number: **A06028**). Each T-piece allows connection of one SeaTalk NG device. Multiple T-pieces can be 'daisy chained' together.
- 2 x Backbone terminators (part number: **A06031**). Terminators must be fitted to both ends of the SeaTalk NG backbone.
- 1 x Power cable 2 m (6.6 ft) (part number: **A06049**). Used to provide 12 V dc power to the SeaTalk NG backbone.

Evolution-Series autopilot cable kit (part number: R70160) consists of:

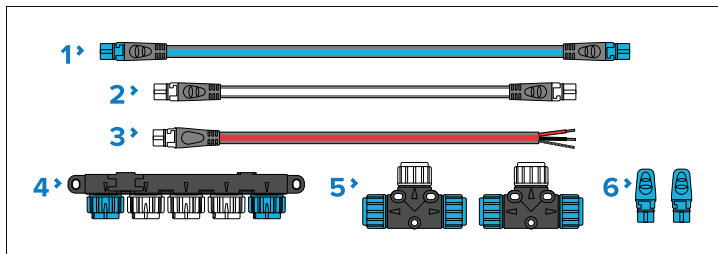

- 1 x Backbone cable 5 m (16.4 ft) (part number: **A06036**). Used to create and extend the SeaTalk NG backbone.
- 1 x Spur cable 1 m (3.3 ft) (part number: **A06040**). Used to connect device to the SeaTalk NG backbone.
- 1 x Power cable 2 m (6.6 ft) (part number: **A06049**). Used to provide 12 V dc power to the SeaTalk NG backbone.

- 1 x 5-Way connector (part number: **A06064**). Each connector block allows connection of up to 3 SeaTalk NG devices. Multiple connector blocks can be 'daisy chained' together.
- 2 x T-pieces (part number: **A06028**). Each T-piece allows connection of one SeaTalk NG device. Multiple T-pieces can be 'daisy chained' together.
- 2 x Backbone terminators (part number: **A06031**). Terminators must be fitted to both ends of the SeaTalk NG backbone.

SeaTalk 1 to SeaTalk NG converter kit (part number: E22158) consists of:

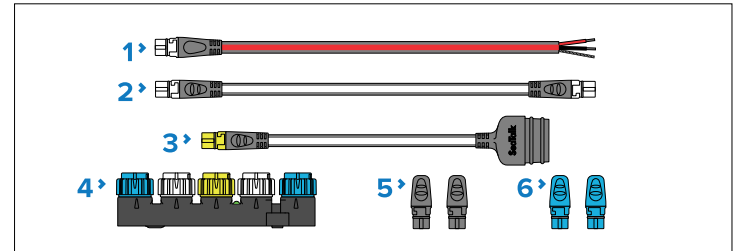

- 1 x Power cable 2 m (6.6 ft) (part number: **A06049**). Used to provide 12 V dc power to the SeaTalk NG backbone.
- 1 x Spur cable 1 m (3.3 ft) (part number: **A06039**). Used to connect a device to the SeaTalk NG backbone.
- 1 x SeaTalk 1 (3 pin) to SeaTalk NG adapter cable 0.4 m (1.3 ft) (part number: **A22164**). Used to connect SeaTalk 1 devices to the SeaTalk NG backbone via the SeaTalk 1 to SeaTalk NG converter.
- 1 x SeaTalk 1 to SeaTalk NG converter (part number: **E22158**). Each converter allows connection of one SeaTalk 1 device and up to 2 SeaTalk NG devices.
- 2 x Spur blanking plugs (part number: **A06032**). Used to cover unused spur connections in 5-way blocks, T-piece connectors and SeaTalk 1 to SeaTalk NG converter.
- 2 x Backbone terminators (part number: **A06031**). Terminators must be fitted to both ends of the SeaTalk NG backbone.

NMEA 0183 VHF 2-wire to SeaTalk NG converter kit (part number: E70196) consists of:

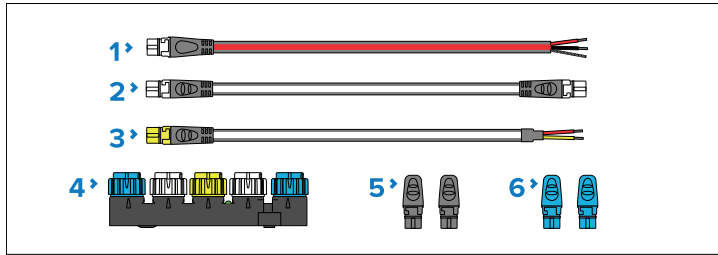

1. 1 x Power cable 2 m (6.6 ft) (part number: **A06049**). Used to provide 12 V dc power to the SeaTalk NG backbone.
2. 1 x Spur cable 1 m (3.3 ft) (part number: **A06039**). Used to connect a device to the SeaTalk NG backbone.
3. 1 x NMEA 0183 VHF stripped-end (2-wire) to SeaTalk NG adapter cable 1 m (3.3 ft) (part number: **A06071**). Used to connect an NMEA 0183 VHF radio to the SeaTalk NG backbone via the NMEA 0183 to SeaTalk NG converter.
4. 1 x SeaTalk 1 to SeaTalk NG converter (part number: **E22158**). Each converter allows connection of one SeaTalk 1 device and up to 2 SeaTalk NG devices.
5. 2 x Spur blanking plugs (part number: **A06032**). Used to cover unused spur connections in 5-way blocks, T-piece connectors, and the SeaTalk 1 to SeaTalk NG converter.
6. 2 x Backbone terminators (part number: **A06031**). Terminators must be fitted to both ends of the SeaTalk NG backbone.

SeaTalk NG spur cables

SeaTalk NG spur cables are required to connect devices to the SeaTalk NG backbone.

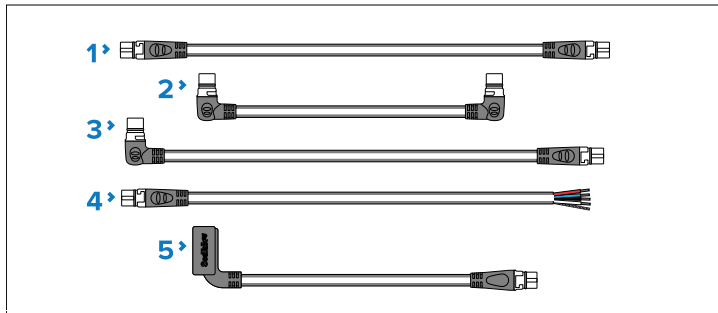

1. SeaTalk NG spur cables:
 - Spur cable 0.4 m (1.3 ft) (part number: **A06038**).
 - Spur cable 1 m (3.3 ft) (part number: **A06039**).
 - Spur cable 3 m (9.8 ft) (part number: **A06040**).
 - Spur cable 5 m (16.4 ft) (part number: **A06041**).
2. Elbow (right-angled) to elbow (right-angled) spur cable 0.4 m (1.3 ft) (part number: **A06042**). Used in confined spaces where a straight spur cable will not fit.
3. Elbow (right-angled) to straight spur cable 1 m (3.3 ft) (part number: **A06081**). Used in confined spaces where a straight spur cable will not fit.
4. SeaTalk NG to stripped-end spur cables (connects compatible products that do not have a SeaTalk NG connector, such as transducer pods):
 - SeaTalk NG to stripped-end spur cable 1 m (3.3 ft) (part number: **A06043**)
 - SeaTalk NG to stripped-end spur cable 3 m (9.8 ft) (part number: **A06044**)
5. ACU-200 / ACU-300 / ACU-400 / SPX-Series autopilot to SeaTalk NG spur cable 0.3 m (1.0 ft) (part number **R12112**). Connects the course computer to the SeaTalk NG backbone. This connection can also be used to provide 12 V dc power to the SeaTalk NG backbone.

SeaTalk NG backbone cables

SeaTalk NG backbone cables are used to create or extend a SeaTalk NG backbone.

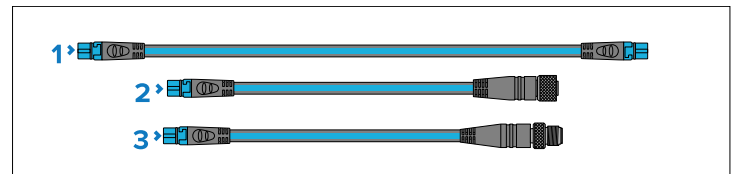

1. Backbone cables:
 - Backbone cable 0.4 m (1.3 ft) (part number: **A06033**).
 - Backbone cable 1 m (3.3 ft) (part number: **A06034**).

- Backbone cable 3 m (9.8 ft) (part number: **A06035**).
 - Backbone cable 5 m (16.4 ft) (part number: **A06036**).
 - Backbone cable 9 m (29.5 ft) (part number: **A06068**).
 - Backbone cable 20 m (65.6 ft) (part number: **A06037**).
2. SeaTalk NG to DeviceNet (female) Backbone cable 0.4 m (1.3 ft) (part number: **A80675**)
 3. SeaTalk NG to DeviceNet (male) Backbone cable 0.4 m (1.3 ft) (part number: **A80674**)

SeaTalk NG power cables

SeaTalk NG power cables are used to provide the SeaTalk NG backbone with a single 12 V dc power source. The power connection must include a 5 amp inline fuse (not supplied).

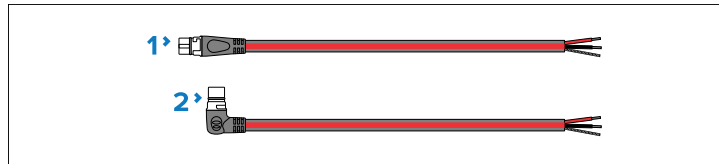

1. Power cable (straight) 2 m (6.6 ft) (part number: **A06049**).
2. Elbow (right-angled) power cable 2 m (6.6 ft) (part number: **A06070**).

SeaTalk NG connectors

SeaTalk NG connectors are used to connect SeaTalk NG devices to the SeaTalk NG backbone and to create and extend the backbone.

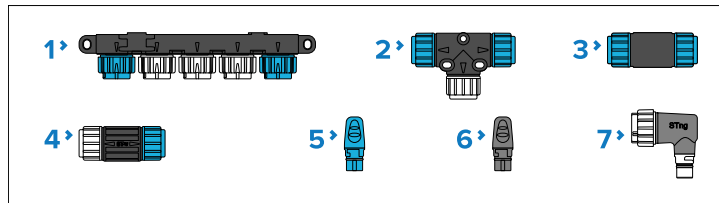

1. 5-Way connector (part number: **A06064**). Each connector block allows connection of up to 3 SeaTalk NG devices. Multiple connector blocks can be 'daisy chained' together.
2. T-piece (part number: **A06028**). Each T-piece allows connection of one SeaTalk NG device. Multiple T-pieces can be 'daisy chained' together.

3. Backbone extender (part number: **A06030**). Used to connect 2 backbone cables together.
4. In-line terminator (part number: **A80001**). Used to connect a spur cable and SeaTalk NG device at the end of a backbone instead of a backbone terminator.
5. Backbone terminator (part number: **A06031**). Terminators must be fitted to both ends of the SeaTalk NG backbone.
6. Spur blanking plug (part number: **A06032**). Used to cover unused spur connections in 5-Way blocks, T-piece connectors, or the SeaTalk 1 to SeaTalk NG converter.
7. Elbow (right-angled) spur connector (part number: **A06077**). Used in confined spaces where a straight spur cable will not fit.

SeaTalk NG adaptors and adaptor cables

SeaTalk NG adaptor cables are used to connect devices designed for different CAN Bus backbones (e.g.: SeaTalk 1 or DeviceNet) to the SeaTalk NG backbone.

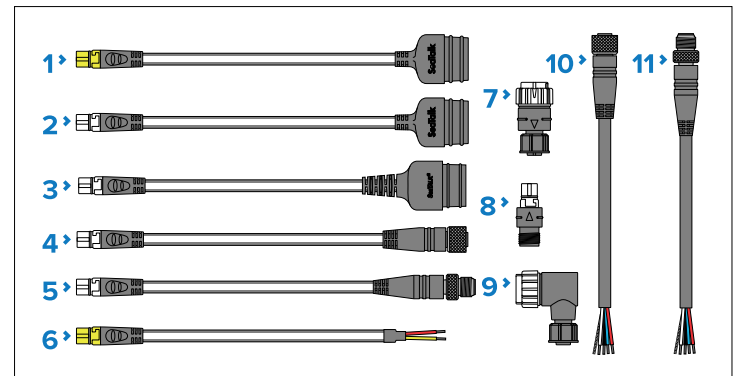

1. SeaTalk 1 (3 pin) to SeaTalk NG converter cable 1 m (3.3 ft) (part number: **A22164 / A06073**). Can be used to connect a SeaTalk 1 device to a SeaTalk NG backbone via the SeaTalk 1 to SeaTalk NG converter, or to connect a SeaTalk NG product directly to a SeaTalk 1 network.
2. SeaTalk 1 (3 pin) to SeaTalk NG adaptor cable 0.4 m (1.3 ft) (part number: **A06047**). Can be used to connect a SeaTalk 1 device to a SeaTalk NG backbone via the SeaTalk 1 to SeaTalk NG converter, or to connect a SeaTalk NG product directly to a SeaTalk 1 network.

3. SeaTalk 2 (5 pin) to SeaTalk NG adaptor cable 0.4 m (1.3 ft) (part number: **A06048**). Used to connect SeaTalk 2 devices or networks to a SeaTalk NG backbone.
4. SeaTalk NG to DeviceNet (female) adaptor cables connect NMEA 2000 devices that use a DeviceNet connector to the SeaTalk NG backbone, or connects SeaTalk NG devices to an NMEA 2000 network. The following cables are available:
 - SeaTalk NG to DeviceNet (female) adaptor cable 0.4 m (1.3 ft) (part number: **A06045**).
 - SeaTalk NG to DeviceNet (female) adaptor cable 1 m (3.3 ft) (part number: **A06075**).
5. SeaTalk NG to DeviceNet (male) adaptor cables. Connect NMEA 2000 devices that use a DeviceNet connector to the SeaTalk NG backbone, or connect SeaTalk NG devices to an NMEA 2000 network. The following cables are available:
 - SeaTalk NG to DeviceNet (male) adaptor cable 0.1 m (0.33 ft) (part number: **A06078**).
 - SeaTalk NG to DeviceNet (male) adaptor cable 0.4 m (1.3 ft) (part number: **A06074**).
 - SeaTalk NG to DeviceNet (male) adaptor cable 1 m (3.3 ft) (part number: **A06076**).
 - SeaTalk NG to DeviceNet (male) adaptor cable 1.5 m (4.92 ft) (part number: **A06046**).
6. NMEA 0183 stripped-end (2-wire) to SeaTalk NG adapter cable 1 m (3.3 ft) (part number: **A06071**). Used to connect an NMEA 0183 VHF radio to the SeaTalk NG backbone via the NMEA 0183 to SeaTalk NG converter.
7. SeaTalk NG (male) to DeviceNet (female) adaptor (**A06082***).
8. SeaTalk NG (female) to DeviceNet (male) adaptor (**A06083***).
9. SeaTalk NG (male) to DeviceNet (female) elbow (right-angled) adaptor (**A06084***).
10. DeviceNet (female) to stripped-end adaptor cable (0.4 m (1.3 ft)) (part number: **E05026**).
11. DeviceNet (male) to stripped-end adaptor cable (0.4 m (1.3 ft)) (part number: **E05027**).

Important:

* Do NOT connect the A06082, A06083, or A06084 adaptors directly to a backbone. Only connect as part of a **spur** connection between backbone and device.

Appendix A NMEA 2000 PGN support

Supported standard NMEA 2000 PGNs are listed below. Proprietary PGNs are not listed.

Note:

Support for some PGNs may be restricted to a specific application.

Administration PGNs

- **59392** — ISO Acknowledge (Transmit)
- **59904** — ISO Request (Receive / Transmit)
- **60160** — ISO Transport Protocol, Data Transfer (Receive)
- **60416** — ISO Transport Protocol, Connection Management — BAM Group Function (Receive)
- **60928** — ISO Address Claim (Receive / Transmit)
- **65240** — ISO Commanded address (Receive)
- **126208** — NMEA — Request, Commanded, Acknowledged Group Function (Receive / Transmit)
- **126464** — PGN Transmit and Receive List (Transmit)
- **126993** — Heartbeat (Receive / Transmit)
- **126996** — Product Information (Transmit)
- **126998** — Configuration Information (Transmit)

Index

A

Accessories	
SeaTalk NG adaptor cables.....	73
SeaTalk NG backbone cables.....	72
SeaTalk NG cables.....	70
SeaTalk NG connectors	73
SeaTalk NG kits.....	70
SeaTalk NG Power cables	73
SeaTalk NG spur cables.....	72
Applicable documents	14
Autopilot systems	
Compatible	17
Evolution	17

B

Backbone length,	
SeaTalk NG.....	43
Batteries	
Inserting	48
Replacement	58
Battery disposal	12, 58
Bluetooth	
Connection	34
Pairing	34
Specification.....	64, 67
Box contents	21
Buttons	49

C

Cable	
Bend radius.....	37
Protection	37–38
Routing	37
Security.....	37
Strain relief.....	37
Cabling	
Circuit isolation	37
Circuit isolation	37

Cleaning	
Screen	58
Compass safe distance	26
Connecting cables	38
Connection	
Bluetooth.....	34
Connections	
Battery	45
Distribution panel	44
Power	41, 43, 46
Power connections	
Power distribution.....	44
Controls	49
Cradle	
Inserting	48
Removing	48

D

Diagnostics	54, 61
Dimensions	23
Wireless Gateway	23
Distribution panel connection	44
Document information	
Latest documentation	14
Documentation	14

E

Environmental specification	67
-----------------------------------	----

F

Fuse requirement	41
------------------------	----

I

Inline fuse	41
Installation	32
Wireless gateway	31

Installation tools	31
Interference.....	26
<i>See also</i> Compass safe distance	

L

Latest documentation	14
LED diagnostics (WG-1).....	55
LEN (Load Equivalency Rating).....	67
Load equivalency number.....	43
Location requirements	25
Wireless	26
Wireless gateway	25
Wireless interference.....	27

M

Maintenance.....	9, 58
Mounting	29
Wireless gateway	31

N

Network length,	
SeaTalk NG.....	43
NMEA 2000	75
LEN	43

P

Parts supplied.....	21
PGNs	75
Power	
Battery connection.....	45
Distribution panel	44
Fuses.....	41
Sharing a breaker	44
Power cable extension.....	42, 45
Power connection point	43
Power specification.....	67
Product dimensions	
Wireless Gateway	23

Product documentation.....	14
Product information.....	61–62
Product loading.....	43
Product overview.....	17
Product recycling (WEEE).....	12
Product support	60

R

Routine checks	58
----------------------	----

S

SeaTalk NG.....	44
Adaptor cables.....	73
Backbone cables.....	72
Connectors	73
Kits.....	70
LEN	43
Load equivalency number.....	43
Power	41, 43, 46
Power cables.....	42, 73
Spur cables	72
System loading	43
SeaTalk NG cables.....	70
Service Center	60
Servicing	9, 58
Software updates	18–19, 27
Specification	
Dimensions	23
Support forum.....	61
Surface mounting	32
System example	18, 38

T

Technical specification	
AHRS.....	64
Battery specification.....	64
Bluetooth.....	64, 67
Conformance specification	65, 67
Environmental.....	67

Environmental specification	64
Physical specification.....	64, 67
Power	67
Product markings.....	65, 68
Technical support.....	60–61
Tools required	29, 31
Training courses.....	61
Troubleshooting	52
Diagnostics	54
Network LED diagnostics.....	55

U

Upgrading, software.....	18
--------------------------	----

W

Warranty.....	12, 60
WEEE Directive	12
What's in the box.....	21