



Raymarine®

iTC-5

Installation Instructions

Document number: 87138 (Rev 5) | English (en-US) | Date: 12-2025

Legal notices

Trademark and patents notice

Raymarine®, Tacktick®, Pathfinder®, Clear Pulse®, Truzoom®, SeaTalk®, SeaTalk HS™, SeaTalk NG™, and MicroNet™, are registered or claimed trademarks of Raymarine UK Ltd.

FLIR®, Fishidy®, Fishing Hot Spots®, YachtSense™, DockSense®, RangeFusion™, DownVision®, SideVision®, RealVision®, HyperVision™, Wi-Fish®, Dragonfly®, Element®, Quantum®, Cyclone™, Alpha™, Axiom®, Infrared Everywhere, The World's Sixth Sense and ClearCruise® are registered or claimed trademarks of Teledyne FLIR LLC.

All other trademarks, trade names, or company names referenced herein are used for identification only and are the property of their respective owners.

This product is protected by patents, design patents, patents pending, or design patents pending.

Fair Use Statement

You may print no more than three copies of this manual for your own use. You may not make any further copies or distribute or use the manual in any other way including without limitation exploiting the manual commercially or giving or selling copies to third parties.

Content notice

Please ensure that you have obtained this document only from Raymarine, and that it is the **latest** available version.

There are numerous third-party Internet websites (such as *www.manualslib.com*) hosting Raymarine product manuals. These websites are not authorized by Raymarine to do so, and are often hosting illegitimate or older versions of Raymarine product manuals, which may contain inaccurate or misleading information.

To obtain the latest official documentation for a Raymarine product, please visit the official Raymarine website: www.docs.raymarine.com

Artificial Intelligence (AI) content notice

There are numerous third-party **Artificial Intelligence (AI)** services available to the public, which are capable of providing a summary or transcription of the information provided by official Raymarine publications or websites, either in written or audio/video formats. These services may alter, supplement, or convey the original information provided by Raymarine in inaccurate or misleading ways.

Please ensure that you have obtained this document only from Raymarine, and that it is the **latest** available version.

CONTENTS

CHAPTER 1 IMPORTANT INFORMATION	8	Analog wind vane transducers.....	17
Safety warnings.....	8	Analog rotavecta transducers.....	17
Product warnings.....	8	Analog fluxgate compass and rudder reference transducers.....	18
Regulatory notices.....	9	Analog depth transducers.....	18
Water ingress.....	9	3.3 Basic system example.....	19
Declaration of Conformity.....	9	3.4 Expanded system example.....	20
PSTI Compliance.....	9	3.5 Software requirement for i70 operation with ITC-5.....	21
Disclaimer.....	9	CHAPTER 4 PARTS SUPPLIED	22
EMC installation guidelines.....	10	4.1 Parts supplied.....	23
Technical accuracy.....	10	CHAPTER 5 PRODUCT DIMENSIONS	24
IMO and SOLAS.....	10	5.1 Product dimensions.....	25
Warranty policy and registration.....	10	CHAPTER 6 LOCATION REQUIREMENTS	26
Product disposal.....	10	6.1 Warnings and cautions.....	27
Publication copyright.....	11	6.2 General location requirements.....	27
CHAPTER 2 DOCUMENT INFORMATION	12	6.3 EMC installation guidelines.....	27
2.1 Applicable products.....	13	6.4 Compass safe distance.....	28
2.2 Product documentation.....	13	6.5 Suppression ferrites.....	28
2.3 Document illustrations.....	13	6.6 Connections to other equipment.....	28
2.4 Applicable software version.....	13	CHAPTER 7 CABLES AND CONNECTIONS — GENERAL INFORMATION	29
CHAPTER 3 PRODUCT AND SYSTEM OVERVIEW	14	7.1 General cabling guidance.....	30
3.1 Product overview.....	15	Cable types and length.....	30
Supported data types.....	15	Cable routing and bend radius.....	30
3.2 Compatible analog transducers overview.....	15	Strain relief.....	30
Analog Depth, Speed and Temperature (DST) transducers.....	16	Circuit isolation.....	30
Analog speed and temperature transducers.....	16		

Cable shielding	31	10.2 Inline fuse requirement	44
Suppression ferrites	31	10.3 Inline fuse and thermal breaker ratings	44
Connecting cables	31	10.4 12 Volt dc only	45
7.2 Basic system example	31	10.5 SeaTalk NG power cables	45
7.3 Expanded system example	32	10.6 SeaTalk NG power cable extension	45
7.4 Connections overview	33	10.7 SeaTalk NG product loading	46
iTC-5 SeaTalk NG connections	33	10.8 SeaTalk NG power connection point	46
CHAPTER 8 MOUNTING	35	10.9 SeaTalk NG system loading	46
8.1 Tools required for installation	36	10.10 Power distribution — SeaTalk NG	47
8.2 Mounting	36	10.11 12 Volt dc only	49
CHAPTER 9 TRANSDUCER CONNECTIONS	38	10.12 Positive ground systems	49
9.1 Making transducer connections	39	10.13 Product grounding	49
9.2 Transducer cable lengths	39	10.14 Power connection via Autopilot Control Unit (ACU-Series)	49
9.3 Transducer connections	39	CHAPTER 11 SYSTEM CALIBRATION	51
Analog Depth, Speed and Temperature (DST) transducer connections	39	11.1 Transducer calibration compatibility	52
Analog speed and temperature transducer connections	40	11.2 Transducer calibration incompatibility	52
Analog wind vane transducer connections	41	11.3 Serial number location	52
Analog rotavecta transducer connections	41	CHAPTER 12 SYSTEM CHECKS AND TROUBLESHOOTING	53
Analog fluxgate compass transducer connections	41	12.1 Troubleshooting	54
Analog rudder reference transducer connections	42	12.2 Typical system checks	54
Analog depth transducer connections	42	12.3 LED diagnostic guidance	54
CHAPTER 10 POWER CONNECTIONS	43	12.4 LED Diagnostics	55
10.1 SeaTalk NG power supply	44	12.5 Power up troubleshooting	59
		12.6 System data troubleshooting	60
		CHAPTER 13 MAINTENANCE	61
		13.1 Service and maintenance	62
		13.2 Routine checks	62
		13.3 Unit cleaning instructions	62

Transducer cleaning	62
Re-applying anti-fouling paint	63
CHAPTER 14 TECHNICAL SUPPORT	64
14.1 Raymarine technical support and servicing	65
14.2 Diagnostic product information	66
14.3 Learning resources	66
CHAPTER 15 TECHNICAL SPECIFICATION	67
15.1 Physical specification	68
15.2 Power specification	68
15.3 Network specification	68
15.4 Environmental specification	68
15.5 Conformance specification.....	68
CHAPTER 16 SPARES AND ACCESSORIES	69
16.1 Spares	70
16.2 SeaTalk NG cables and accessories	70
APPENDIX A SUPPORTED NMEA 2000 PGNS	75

CHAPTER 1: IMPORTANT INFORMATION

Safety warnings



Warning: Product installation and operation

- This product must be installed and operated in accordance with the instructions provided. Failure to do so could result in personal injury or damage to your vessel. It may also cause poor product performance or invalidate the product warranty.
- Raymarine highly recommends certified installation by a Raymarine approved installer. A certified installation qualifies for enhanced product warranty benefits. Register your warranty on the Raymarine website: www.bit.ly/rym-warranty



Warning: Switch off power supply

Ensure that the vessel's power supply is switched OFF before starting to install this product. Do NOT connect or disconnect equipment with the power switched on, unless instructed to do so in this document.



Warning: Exposed wires

With the cover open, the exposed transducer wires provide a potential for electric shock. Use caution when making connections.



Warning: iTC-5 High voltage

Do NOT touch exposed transducer wires whilst the converter is powered on and the cover is open or removed.



Warning: Potential ignition source

This product is NOT approved for use in hazardous/flammable atmospheres. Do NOT install in a hazardous/flammable atmosphere (such as in an engine room or near fuel tanks).

Caution: Power supply protection

When installing this product, ensure that the power source is adequately protected by means of a suitably-rated fuse or thermal circuit breaker.

Product warnings



Warning: 12 Volt dc only

This product must ONLY be connected to a 12 V dc power source.



Warning: Positive ground systems

Do NOT connect this unit to a system which has positive grounding.



Warning: Power supply voltage

Connecting this product to a voltage supply greater than the specified maximum rating may cause permanent damage to the unit. For the correct voltage, refer to the information label affixed to the product.

Caution: Power supply protection

When installing this product, ensure that the power source is adequately protected by means of a suitably-rated fuse or thermal circuit breaker.

Caution: Service and maintenance

This product contains no user serviceable components. Please refer all maintenance and repair to authorized Raymarine dealers. Unauthorized repair may affect your warranty.

Regulatory notices

Water ingress

Water ingress disclaimer



Although the waterproof rating capacity of this product meets the stated water ingress protection standard (refer to the product's *Technical Specification*), water intrusion and subsequent equipment failure may occur if the product is not installed correctly or subjected to high-pressure washing. Raymarine will not warrant products subjected to high-pressure washing.

Declaration of Conformity

Declaration of Conformity for product sold into EU member state regions.

Raymarine UK Ltd declares that the products listed below are in conformity with the relevant sections of the listed designated standards and / or other normative documents:

- iTC-5 Converter, part number: E70010

Region	Standard	Mark
UK	EMC Regulations 2016	
EU	EMC Directive 2014/30/EU	

The original Declaration of Conformity certificate may be viewed at: www.bit.ly/itc-5-docs

PSTI Compliance

For products sold into the United Kingdom (UK), use the following link to obtain the product's Statement of Compliance with the *Product Security and Telecommunications Infrastructure* (PSTI) Regulations:

Visit the following web address and enter the product's model name or number (SKU) into the provided search field:

- www.bit.ly/rym-sec-com

Disclaimer

Raymarine does not warrant that this product is error-free or that it is compatible with products manufactured by any person or entity other than Raymarine.

Raymarine is not responsible for damages or injuries caused by your use or inability to use the product, by the interaction of the product with products manufactured by others, or by errors in information utilized by the product supplied by third parties.

Third-party hardware, such as converters, adapters, routers, switches, Access Points etc., provided by third parties, may be made available directly to you by other companies or individuals under separate terms and conditions, including separate fees and charges. Raymarine UK Ltd or its affiliates have not tested or screened the third-party hardware.

Raymarine has no control over, and is not responsible for:

- (a) the content and operation of such third-party hardware; or
- (b) the privacy or other practices of such third-party hardware.

The fact that Raymarine's documentation may make reference to such third-party hardware does not indicate any approval or endorsement of any such third-party hardware. Raymarine may reference such third-party hardware only as a convenience.

THIS INFORMATION IS MADE AVAILABLE BY Raymarine ON THE BASIS THAT YOU EXCLUDE TO THE FULLEST EXTENT LAWFULLY PERMITTED ALL LIABILITY WHATSOEVER FOR ANY LOSS OR DAMAGE HOWSOEVER ARISING OUT OF THE USE OF THIS INFORMATION OR RELIANCE UPON THIS INFORMATION.

Raymarine does not exclude Raymarine's liability (if any) to you for personal injury or death resulting from Raymarine UK Ltd negligence, for fraud or for any matter which it would be illegal to exclude or to attempt to exclude.

EMC installation guidelines

Raymarine equipment and accessories conform to the appropriate Electromagnetic Compatibility (EMC) regulations, to minimize electromagnetic interference between equipment and minimize the effect such interference could have on the performance of your system.

Correct installation is required to ensure that EMC performance is not compromised.

Note:

In areas of extreme EMC interference, some slight interference may be noticed on the product. Where this occurs the product and the source of the interference should be separated by a greater distance.

For **optimum** EMC performance we recommend that wherever possible:

- Raymarine equipment and cables connected to it are:
 - At least 1 m (3.28 ft) from any equipment transmitting or cables carrying radio signals e.g. VHF radios, cables and antennas. In the case of SSB radios, the distance should be increased to 2 m (6.6 ft).
 - More than 2 m (6.56 ft) from the path of a radar beam. A radar beam can normally be assumed to spread 20 degrees above and below the radiating element.
- The product is supplied from a separate battery from that used for engine start. This is important to prevent erratic behavior and data loss which can occur if the engine start does not have a separate battery.
- Raymarine specified cables are used.
- Cables are not cut or extended, unless doing so is detailed in the installation manual.

Note:

Where constraints on the installation prevent any of the above recommendations, always ensure the maximum possible separation between different items of electrical equipment, to provide the best conditions for EMC performance throughout the installation.

Technical accuracy

To the best of our knowledge, the information in this document was correct at the time it was produced. However, Raymarine cannot accept liability for any inaccuracies or omissions it may contain. In addition, our policy of continuous product improvement may change specifications without notice. As a result, Raymarine cannot accept liability for any differences between the product and this document. Please check the Raymarine website to ensure you have the most up-to-date version(s) of the documentation for your product: www.docs.raymarine.com

IMO and SOLAS

The equipment described within this document is intended for use on leisure marine boats and workboats NOT covered by International Maritime Organization (IMO) and Safety of Life at Sea (SOLAS) Carriage Regulations.

Warranty policy and registration

Visit the Raymarine website to **read the latest warranty policy**, and **register** your product's warranty online: www.bit.ly/rym-warranty

It is important that you register your product to receive full warranty benefits. Your product package includes a barcode label indicating the serial number of the unit. This serial number is also provided on a label affixed to the product itself. You will need this serial number when registering your product online.

Product disposal

Dispose of this product in accordance with the WEEE Directive.

The Waste Electrical and Electronic Equipment (WEEE) Directive requires the recycling of waste electrical and electronic equipment which contains materials, components and substances that may be hazardous and present a risk to human health and the environment when WEEE is not handled correctly.



Equipment marked with the crossed-out wheeled bin symbol indicates that the equipment should not be disposed of in unsorted household waste. Local authorities in many regions have established collection schemes under which residents can dispose of waste electrical and electronic equipment at a recycling center or other collection point. For more information about suitable collection points for waste electrical and electronic equipment in your region, refer to the Raymarine website: <https://bit.ly/rym-recycling>

Publication copyright

Copyright ©2025 Raymarine UK Ltd. All rights reserved. No parts of this material may be copied, translated, or transmitted (in any medium) without the prior written permission of Raymarine UK Ltd.

CHAPTER 2: DOCUMENT INFORMATION

CHAPTER CONTENTS

- 2.1 Applicable products — page 13
- 2.2 Product documentation — page 13
- 2.3 Document illustrations — page 13
- 2.4 Applicable software version — page 13

2.1 Applicable products

This document is applicable to the following product:

- iTC-5 Instrument transducer converter, part number: E70010

2.2 Product documentation

The following documentation is applicable to your product:

Applicable documents

Document	Description
87138	iTC-5 Installation Instructions (this document)

Related documents

Document	Description
81300	SeaTalk NG reference manual

Documents download link

These documents are available to download from the following location:

iTC-5 documents download link
www.bit.ly/itc-5-docs

2.3 Document illustrations

Your product and if applicable, its user interface may differ slightly from that shown in the illustrations in this document, depending on product variant and date of manufacture.

All images are provided for illustration purposes only.

2.4 Applicable software version

Product software is updated regularly to add new features and improve existing functionality.

This document has been updated to reflect the following iTC-5 software version:

Applicable software version:

v1.12

Check the website for the latest software:

iTC-5 software download link

www.bit.ly/itc5-download

CHAPTER 3: PRODUCT AND SYSTEM OVERVIEW

CHAPTER CONTENTS

- 3.1 Product overview — page 15
- 3.2 Compatible analog transducers overview — page 15
- 3.3 Basic system example — page 19
- 3.4 Expanded system example — page 20
- 3.5 Software requirement for i70 operation with iTC-5 — page 21

3.1 Product overview

The iTC-5 converter allows connection of a range of compatible analog transducers directly to the SeaTalk NG network.

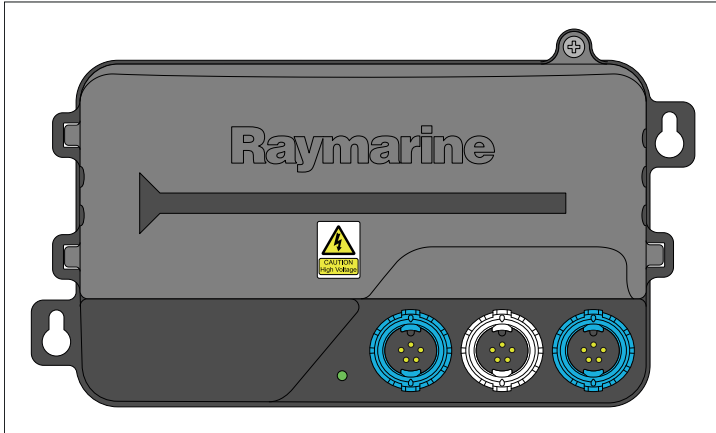

Supported data types

The following data types are supported by the iTC-5 converter:

- Apparent Wind Angle (AWA).
- Apparent Wind Speed (AWS).
- Depth.
- Speed Through Water (STW).
- Log distance.
- Trip distance.
- Sea and temperature.
- Rudder angle.
- Vessel heading.

3.2 Compatible analog transducers overview

The following types of analog transducers are supported by the iTC-5 converter.

- **p.16 — Analog Depth, Speed and Temperature (DST) transducers**
- **p.16 — Analog speed and temperature transducers**
- **p.17 — Analog wind vane transducers**
- **p.17 — Analog rotavecta transducers**
- **p.18 — Analog fluxgate compass and rudder reference transducers**
- **p.18 — Analog depth transducers**

Note:

If a fishfinder is connected to your system, ensure that it does not operate at the same frequency as the instrument depth transducer.

Analog Depth, Speed and Temperature (DST) transducers

The iTC-5 converter is compatible with the following analog depth, speed and temperature (DST) transducers.

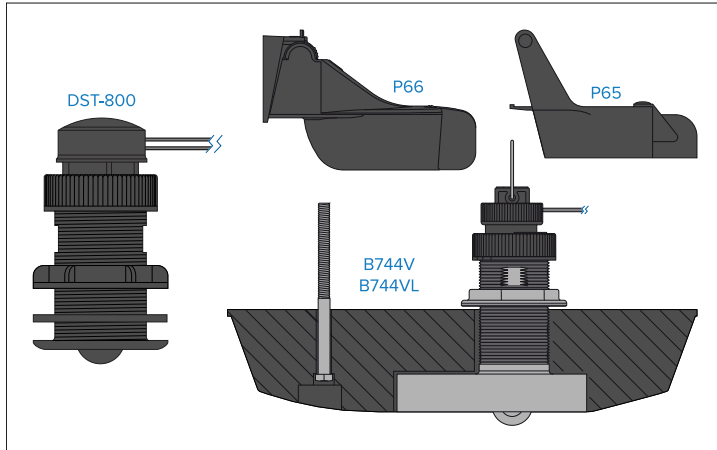

Part	Transducer description
A22154	DST-800 Thru-hull
E26028-PZ	P66 Transom mount
E26006-PZ	P65 / ST40 Transom mount
A26043	B744V (including fairing block) Thru-hull
A26044	B744VL (including fairing block) Thru-hull

Analog speed and temperature transducers

The iTC-5 converter is compatible with the following analog speed and temperature transducers.

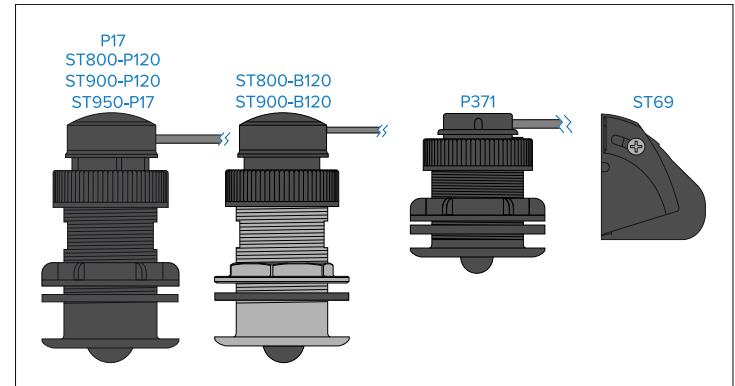

Part	Description
E25025	P17 Thru-hull
E26031	ST800-P120 Thru-hull.
E70673	ST900-P120 Thru-hull, with 13.7 m (44.95 ft) fitted cable.
E70674	ST900-P120 Thru-hull, with 20 m (65.62 ft) fitted cable.
E66072	ST800-B120 Thru-hull.
E70686	ST900-B120 Thru-hull, with 13.7 m (44.95 ft) fitted cable.
E70687	ST950-P17 Thru-hull with 6 m (19.69 ft) fitted cable.
E26008	P371 Thru-hull.
E26005	ST69 Transom mount.

Analog wind vane transducers

The iTC-5 converter is compatible with the following analog wind vane transducers.

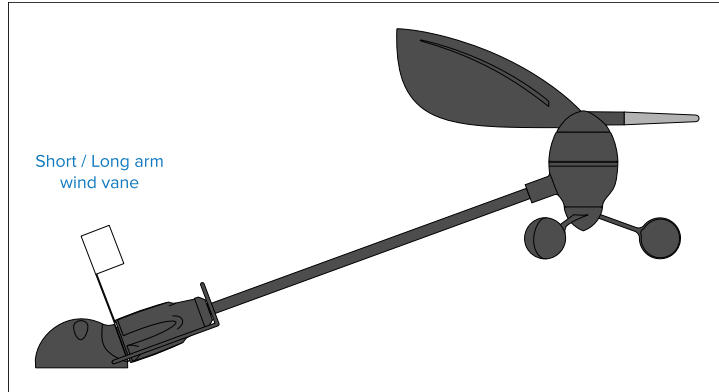

Part	Transducer description
E22078	Short arm wind vane
E22079	Long arm wind vane

Analog rotavecta transducers

The iTC-5 converter is compatible with the following analog rotavecta transducers.

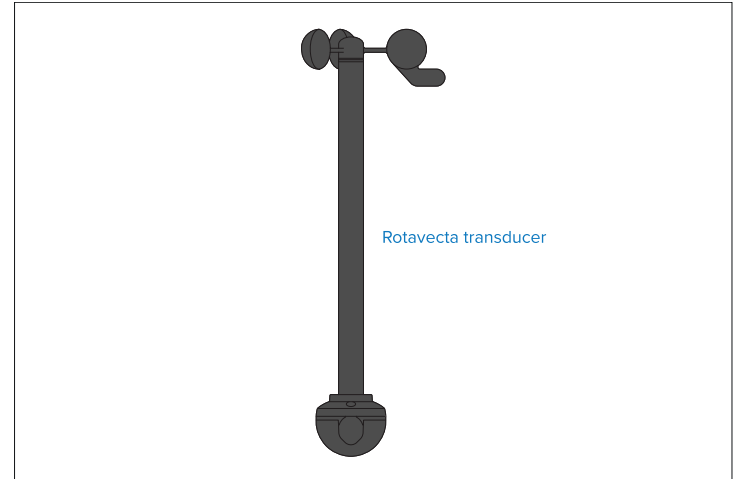

Part	Transducer description
Z195	Rotavecta transducer

Analog fluxgate compass and rudder reference transducers

The iTC-5 converter is compatible with the following analog fluxgate compass and rudder reference transducers.

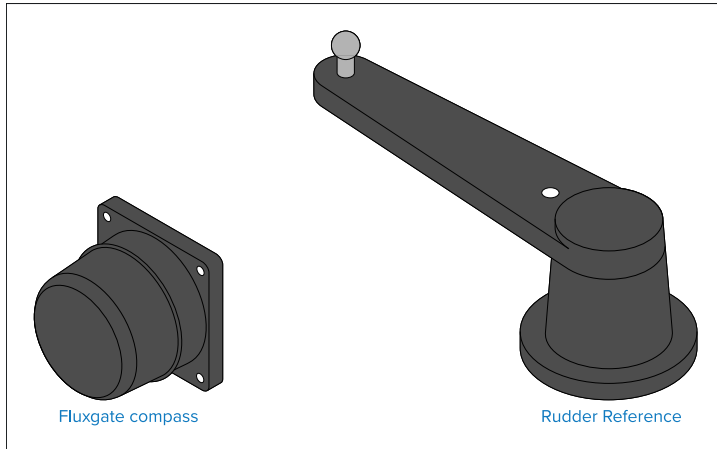

Part	Description
M81190	Fluxgate compass
M81105	Rudder Reference

Analog depth transducers

The iTC-5 converter is compatible with the following analog depth transducers.

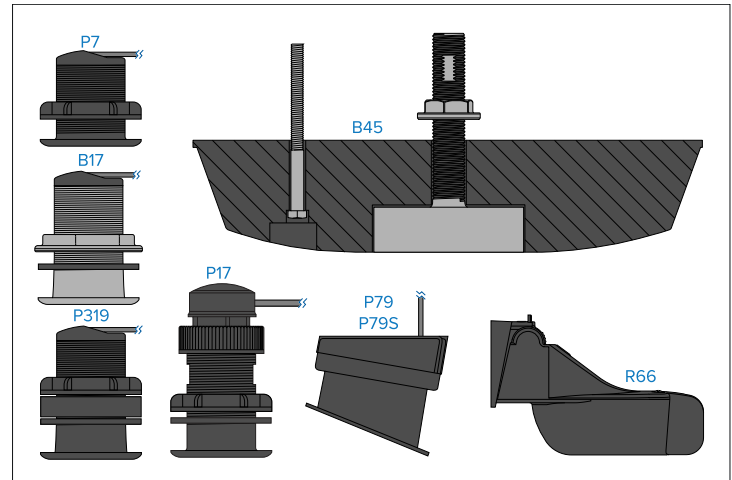

Part	Transducer description
E26009	P7 Thru-hull
E26019-PZ	B45 (including fairing block) Thru-hull
M78717	B17 Thru-hull
M78713-PZ	P319 Thru-hull
E26030	P17 Thru-hull
E26001-PZ	P79 In-hull
A80373 T70278	P79S In-hull — (includes SeaTalk NG adaptor)
E26027-PZ	P66 Transom mount

3.3 Basic system example

The following example provides an overview of a *basic system*, including the available connections and the types of analog transducers that can be connected to your iTC-5.

Note:

This system is shown as an example only, and may differ from your planned installation.

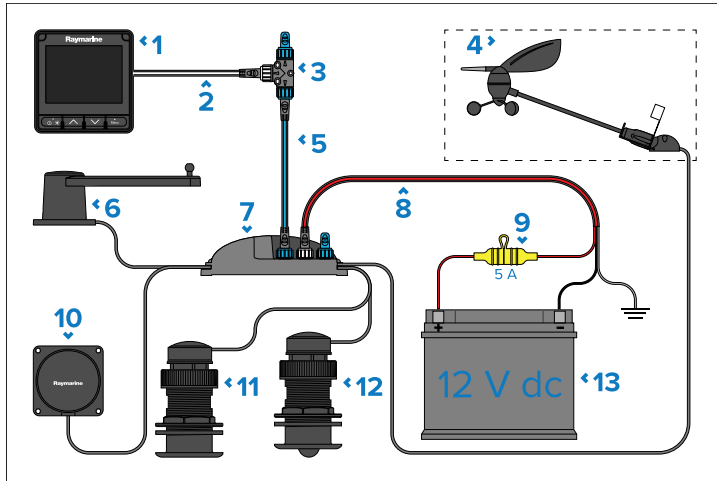

Description

- 1 i70s Instrument display.
- 2 SeaTalk NG spur cable.
- 3 SeaTalk NG T-piece connector with Terminator fitted.
- 4 Wind transducer (Analog).
- 5 SeaTalk NG backbone cable.
- 6 Rudder reference transducer (Analog).
- 7 iTC-5 with terminator fitted.
- 8 SeaTalk NG power cable.

Description

- 9 5 A fuse in waterproof fuse holder.
- 10 Fluxgate compass transducer (Analog).
- 11 Depth transducer (Analog).
- 12 Speed / Temperature transducer (Analog).
- 13 12 V dc power supply.

Note:

For information on how to connect your products, refer to the following sections:

- [p.29 – Cables and connections – General information](#)
- [p.38 – Transducer connections](#)
- [p.43 – Power connections](#)

For information on the available cables and accessories, refer to the following section: [p.69 – Spares and accessories](#)

3.4 Expanded system example

The following example provides an overview of an *expanded system*, including the available connections and the types of analog transducers that can be connected to your iTC-5.

Note:

This system is shown as an example only, and may differ from your planned installation.

Note:

Depending on engine type, it may be possible to connect the engine system directly to the SeaTalk NG backbone using a SeaTalk NG to DeviceNet adaptor cable. However, the data available will be restricted to supported, standard NMEA 2000 data only.

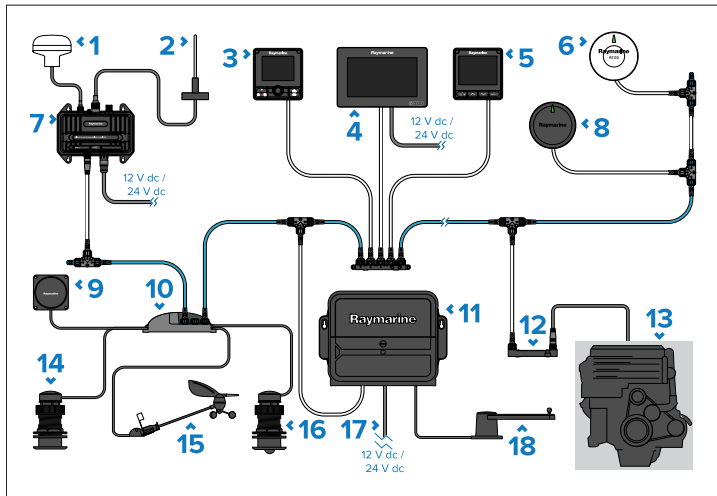

Description

- 1 AIS dedicated GNSS (GPS) receiver.
- 2 VHF antenna.

Description

- 3 SeaTalk NG pilot controller (e.g.: p70Rs).
- 4 MFD / chartplotter (e.g.: Axiom+).
- 5 i70s instrument display.
- 6 GNSS (GPS) (e.g.: RS150).
- 7 AIS receiver / transceiver (e.g.: AIS700).
- 8 Evolution autopilot (e.g.: EV-1).
- 9 Fluxgate compass (Analog).
- 10 iTC-5.
- 11 Autopilot control unit (e.g.: ACU-400).
- 12 ECI-100.
- 13 Vessel / Engine systems.
- 14 Depth transducer (Analog).
- 15 Wind transducer (Analog).
- 16 Speed / Temperature transducer (Analog).
- 17 12 V dc / 24 V dc power supply (supplying 12 V dc to the SeaTalk NG backbone via the ACU-400).
- 18 Rudder reference transducer (Analog).

Note:

For information on how to connect your products, refer to the following sections:

- [p.29 – Cables and connections – General information](#)
- [p.38 – Transducer connections](#)
- [p.43 – Power connections](#)

For information on the available cables and accessories, refer to the following section: [p.69 – Spares and accessories](#)

3.5 Software requirement for i70 operation with iTC-5

i70 operation with iTC-5 converters requires i70 / i70s software version **v1.25**, or later.

If your i70 instrument is running a software version that is lower (earlier) than v1.25, you must upgrade the i70 / i70s software to version **v1.25** or later before you can use the i70 with the iTC-5 converter.

CHAPTER 4: PARTS SUPPLIED

CHAPTER CONTENTS

- [4.1 Parts supplied — page 23](#)

4.1 Parts supplied

The iTC-5 converter is supplied with the following items:

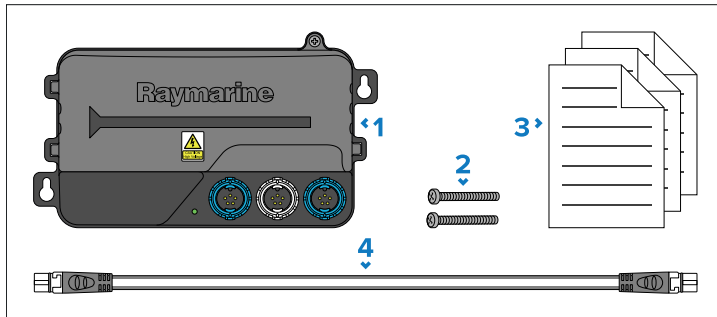

Description	
1	iTC-5
2	2x fixing screws
3	Documentation
4	SeaTalk NG spur cable, 0.4 m (1.3 ft).

CHAPTER 5: PRODUCT DIMENSIONS

CHAPTER CONTENTS

- [5.1 Product dimensions — page 25](#)

5.1 Product dimensions

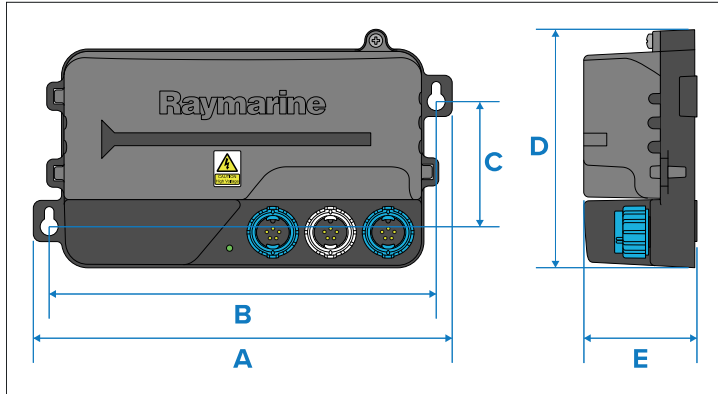

Description	
A	163.50 mm (6.44 in)
B	151.10 mm (5.95 in)
C	48.85 mm (1.92 in)
D	93.10 mm (3.66 in)
E	44.30 mm (1.74 in)

CHAPTER 6: LOCATION REQUIREMENTS

CHAPTER CONTENTS

- 6.1 Warnings and cautions — page 27
- 6.2 General location requirements — page 27
- 6.3 EMC installation guidelines — page 27
- 6.4 Compass safe distance — page 28
- 6.5 Suppression ferrites — page 28
- 6.6 Connections to other equipment — page 28

6.1 Warnings and cautions

Important:

Before proceeding, ensure that you have read and understood the warnings and cautions provided in the following section of this document:

- [p.8 — Important information](#)



Warning: Potential ignition source

This product is NOT approved for use in hazardous/flammable atmospheres. Do NOT install in a hazardous/flammable atmosphere (such as in an engine room or near fuel tanks).

6.2 General location requirements

When selecting a location for your product it is important to consider a number of factors.

Factors for consideration:

- **Ventilation** — To ensure adequate airflow:
 - Ensure that product is mounted in a compartment of suitable size.
 - Ensure that ventilation holes are not obstructed. Allow adequate separation of all equipment.
- **Mounting surface** — Ensure product is adequately supported on a secure surface. Do not mount units or cut holes in places which may damage the structure of the vessel.
- **Cabling** — Ensure the product is mounted in a location which allows proper routing, support and connection of cables:
 - Minimum bend radius of 100 mm (3.94 in.) unless otherwise stated.
 - Use cable clips to prevent stress on connectors.
 - If your installation requires multiple ferrites to be added to a cable then additional cable clips should be used to ensure the extra weight of the cable is supported.
- **Water ingress** — The product is NOT protected against the ingress of moisture or liquids. The product should be located in

a protected area away from moisture and exposure to rain and salt spray.

- **Electrical interference and noise** — Select a location that is far enough away from devices that may cause interference, such as motors, generators and radio transmitters / receivers. Avoid the use of sub-standard sources of electrical power which may generate ripple or radiated noise, such as poor quality DC regulators or converters.
- **Power supply** — Select a location that is as close as possible to the vessel's DC power source. This will help to keep cable runs to a minimum.

6.3 EMC installation guidelines

Raymarine equipment and accessories conform to the appropriate Electromagnetic Compatibility (EMC) regulations, to minimize electromagnetic interference between equipment and minimize the effect such interference could have on the performance of your system.

Correct installation is required to ensure that EMC performance is not compromised.

Note:

In areas of extreme EMC interference, some slight interference may be noticed on the product. Where this occurs the product and the source of the interference should be separated by a greater distance.

For **optimum** EMC performance we recommend that wherever possible:

- Raymarine equipment and cables connected to it are:
 - At least 1 m (3.28 ft) from any equipment transmitting or cables carrying radio signals e.g. VHF radios, cables and antennas. In the case of SSB radios, the distance should be increased to 2 m (6.6 ft).
 - More than 2 m (6.56 ft) from the path of a radar beam. A radar beam can normally be assumed to spread 20 degrees above and below the radiating element.
- The product is supplied from a separate battery from that used for engine start. This is important to prevent erratic behavior and data

loss which can occur if the engine start does not have a separate battery.

- Raymarine specified cables are used.
- Cables are not cut or extended, unless doing so is detailed in the installation manual.

Note:

Where constraints on the installation prevent any of the above recommendations, always ensure the maximum possible separation between different items of electrical equipment, to provide the best conditions for EMC performance throughout the installation.

6.4 Compass safe distance

To prevent potential interference with the vessel's magnetic compasses, ensure an adequate distance is maintained from the product.

When choosing a suitable location for the product, you must aim to maintain a distance of **at least 1 m (3.3 ft.)** in all directions from any compasses.

For some smaller vessels it may not be possible to locate the product this far away from a compass. In this situation, when choosing the installation location for your product, ensure that the compass is not affected by the product when it is in a powered on state.

6.5 Suppression ferrites

- Raymarine cables may be pre-fitted or supplied with suppression ferrites. These are important for correct EMC performance. If ferrites are supplied separately to the cables (i.e. not pre-fitted), you must fit the supplied ferrites, using the supplied instructions.
- If a ferrite has to be removed for any purpose (e.g. installation or maintenance), it must be replaced in the original position before the product is used.
- Use only ferrites of the correct type, supplied by Raymarine or its authorized dealers.
- Where an installation requires multiple ferrites to be added to a cable, additional cable clips should be used to prevent stress on the connectors due to the extra weight of the cable.

6.6 Connections to other equipment

Requirement for ferrites on non-Raymarine cables:

If your Raymarine equipment is to be connected to other equipment using a cable not supplied by Raymarine, a suppression ferrite **MUST** always be attached to the cable near the Raymarine unit.

For more information, refer to your third-party cable manufacturer.

CHAPTER 7: CABLES AND CONNECTIONS — GENERAL INFORMATION

CHAPTER CONTENTS

- [7.1 General cabling guidance — page 30](#)
- [7.2 Basic system example — page 31](#)
- [7.3 Expanded system example — page 32](#)
- [7.4 Connections overview — page 33](#)

7.1 General cabling guidance

Cable types and length

It is important to use cables of the appropriate type and length.

- Unless otherwise stated only use cables supplied by Raymarine.
- Where it is necessary to use non-Raymarine cables, ensure that they are of correct quality and gauge for their intended purpose. (e.g.: longer power cable runs may require larger wire gauges to minimize voltage drop along the run).

Cable routing and bend radius

To maximize cable performance and lifespan, it's important to ensure that all cables are routed correctly and adequate space is provided to allow for each cable's minimum bend radius.

Minimum cable bend radius

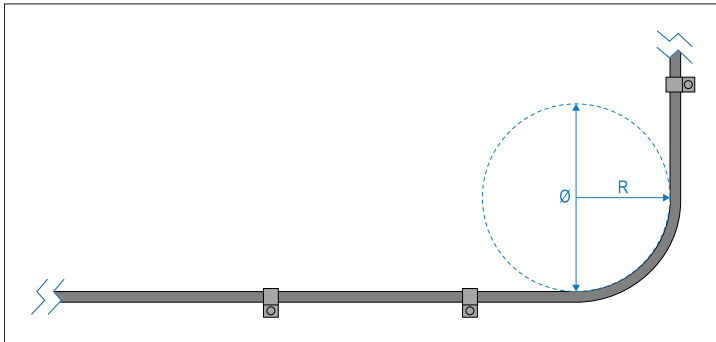

Do NOT bend cables excessively. Wherever possible, ensure that your chosen product installation location allows enough clearance for the minimum cable bend diameter specified in the following table:

	Description	Value
Ø	Cable minimum bend diameter .	200 mm (7.87 in.)
R	Cable minimum bend radius .	100 mm (3.94 in.)

Note:

For products where multiple different cable types are connected, each with a different minimum cable bend radius, the higher figure is provided in the table above (i.e. the cable with the greatest minimum bend radius is specified).

Cable routing — best practices

- Protect all cables from physical damage and exposure to heat. Use trunking or conduit where possible. Do NOT run cables through bilges or doorways, or close to moving or hot objects.
- Secure cables in place using cable clips or cable ties. Coil any excess cable and tie it out of the way.
- Where a cable passes through an exposed bulkhead or deckhead, use a suitable watertight feed-through (conduit).
- Do NOT run cables near to engines or fluorescent lights.
- Always route data cables as far away as possible from:
 - Other equipment and cables.
 - High current-carrying AC and DC power lines.
 - Antennas.

Strain relief

Use adequate strain relief for cabling to ensure that connectors are protected from strain and will not pull out under extreme sea conditions.

Circuit isolation

Appropriate circuit isolation is required for installations using both AC and DC current:

- Always use isolating transformers or a separate power-inverter to run PCs, processors, displays and other sensitive electronic instruments or devices.
- If using Weather FAX audio cables, always use an isolating transformer.
- If using a third-party audio amplifier, always use an isolated power supply.
- If using an RS232/NMEA converter, always ensure optical isolation on the signal lines.

- Always ensure that PCs or other sensitive electronic devices have a dedicated power circuit.

Cable shielding

Ensure that cable shielding is not damaged during installation and that all cables are properly shielded.

Important:

Be aware that some **third-party** cables and adapters (for example, certain Ethernet cables using RJ45 connectors) are not always shielded. To prevent breaks in cable shielding continuity and potential grounding issues, special attention is required to ensure that any cables, extension cables, adapters, or other signal-coupling devices used in cable runs **maintain all shield connections throughout the cable run.**

Suppression ferrites

- Raymarine cables may be pre-fitted or supplied with suppression ferrites. These are important for correct EMC performance. If ferrites are supplied separately to the cables (i.e. not pre-fitted), you must fit the supplied ferrites, using the supplied instructions.
- If a ferrite has to be removed for any purpose (e.g. installation or maintenance), it must be replaced in the original position before the product is used.
- Use only ferrites of the correct type, supplied by Raymarine or its authorized dealers.
- Where an installation requires multiple ferrites to be added to a cable, additional cable clips should be used to prevent stress on the connectors due to the extra weight of the cable.

Connecting cables

Follow the steps below to connect the cable(s) to your product.

1. Ensure that the vessel's power supply is switched off.
2. Ensure that the device being connected has been installed in accordance with the installation instructions supplied with that device.
3. Ensuring correct orientation, push cable connectors fully onto the corresponding connectors.

4. Engage any locking mechanism to ensure a secure connection (e.g.: turn locking collars clockwise until tight, or in the locked position).
5. Ensure any bare ended wire connections are suitably insulated to prevent shorting and corrosion due to water ingress.

7.2 Basic system example

The following example provides an overview of a *basic system*, including the available connections and the types of analog transducers that can be connected to your iTC-5.

Note:

This system is shown as an example only, and may differ from your planned installation.

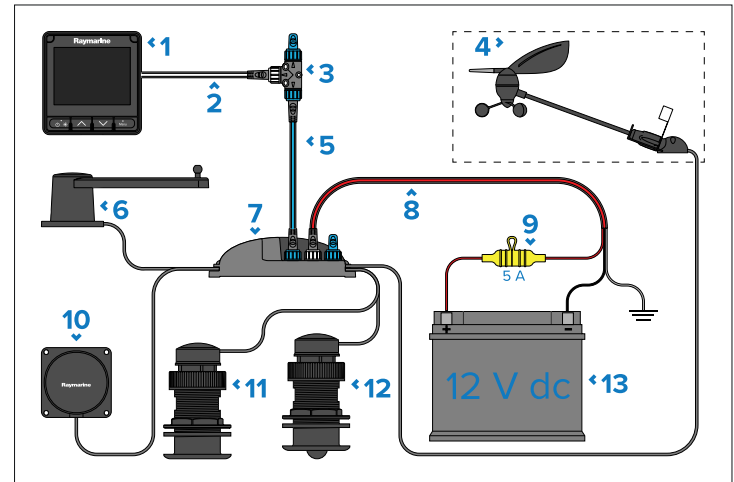

Description

- | Number | Description |
|--------|--|
| 1 | i70s Instrument display. |
| 2 | SeaTalk NG spur cable. |
| 3 | SeaTalk NG T-piece connector with Terminator fitted. |
| 4 | Wind transducer (Analog). |

Description	
5	SeaTalk NG backbone cable.
6	Rudder reference transducer (Analog).
7	iTC-5 with terminator fitted.
8	SeaTalk NG power cable.
9	5 A fuse in waterproof fuse holder.
10	Fluxgate compass transducer (Analog).
11	Depth transducer (Analog).
12	Speed / Temperature transducer (Analog).
13	12 V dc power supply.

Note:

For information on how to connect your products, refer to the following sections:

- [p.29 – Cables and connections – General information](#)
- [p.38 – Transducer connections](#)
- [p.43 – Power connections](#)

For information on the available cables and accessories, refer to the following section: [p.69 – Spares and accessories](#)

7.3 Expanded system example

The following example provides an overview of an *expanded system*, including the available connections and the types of analog transducers that can be connected to your iTC-5.

Note:

This system is shown as an example only, and may differ from your planned installation.

Note:

Depending on engine type, it may be possible to connect the engine system directly to the SeaTalk NG backbone using a SeaTalk NG to DeviceNet adaptor cable. However, the data available will be restricted to supported, standard NMEA 2000 data only.

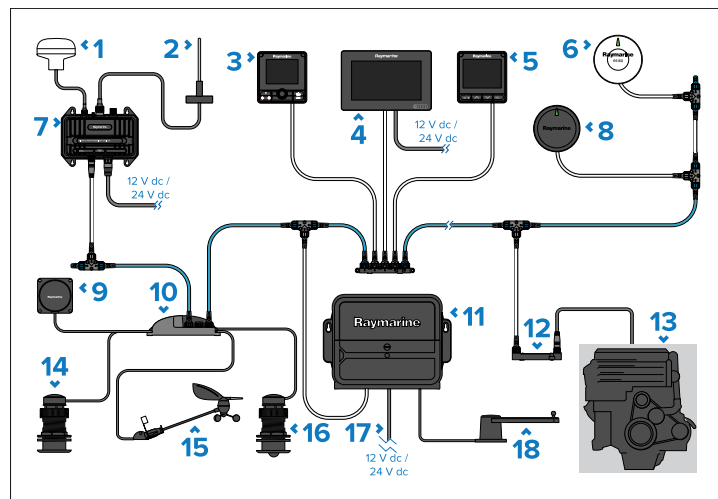

Description	
1	AIS dedicated GNSS (GPS) receiver.
2	VHF antenna.
3	SeaTalk NG pilot controller (e.g.: p70Rs).

	Description
4	MFD / chartplotter (e.g.: Axiom+).
5	i70s instrument display.
6	GNSS (GPS) (e.g.: RS150).
7	AIS receiver / transceiver (e.g.: AIS700).
8	Evolution autopilot (e.g.: EV-1).
9	Fluxgate compass (Analog).
10	iTC-5.
11	Autopilot control unit (e.g.: ACU-400).
12	ECI-100.
13	Vessel / Engine systems.
14	Depth transducer (Analog).
15	Wind transducer (Analog).
16	Speed / Temperature transducer (Analog).
17	12 V dc / 24 V dc power supply (supplying 12 V dc to the SeaTalk NG backbone via the ACU-400).
18	Rudder reference transducer (Analog).

Note:

For information on how to connect your products, refer to the following sections:

- [p.29 — Cables and connections — General information](#)
- [p.38 — Transducer connections](#)
- [p.43 — Power connections](#)

For information on the available cables and accessories, refer to the following section: [p.69 — Spares and accessories](#)

7.4 Connections overview

The iTC-5 converter connects inline as part of the SeaTalk NG backbone. It provides connections to enable transducers to be installed onto the SeaTalk NG network.

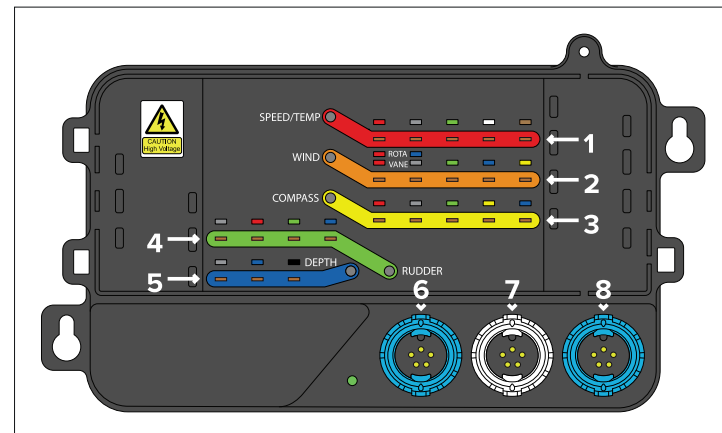

	Color	Description
1	Red	Speed and sea temperature transducer connection.
2	Orange	Wind transducer and rotavecta connection.
3	Yellow	Fluxgate compass connection.
4	Green	Rudder reference transducer connection.
5	Blue	Depth transducer connection.
6	—	SeaTalk NG backbone connection.
7	—	SeaTalk NG spur connection.
8	—	SeaTalk NG backbone connection.

iTC-5 SeaTalk NG connections

The iTC-5 converter connects inline with the SeaTalk NG backbone, and includes a spur connector to enable connection of another SeaTalk NG device to the backbone.

SeaTalk NG backbone connectors

The SeaTalk NG backbone connectors enable the converter to be connected inline as part of the SeaTalk NG backbone.

SeaTalk NG spur connector

The spur connector enables connection of another SeaTalk NG device, or connection to a suitable 12 V dc power supply.

Note:

Do NOT connect the spur connector to another spur connection on the backbone.

2. Ensure the cable's connector is correctly oriented (groove pointing up).
3. Fully insert the cable connector.
4. Rotate the locking collar clockwise (2 clicks) until it is in the locked position.

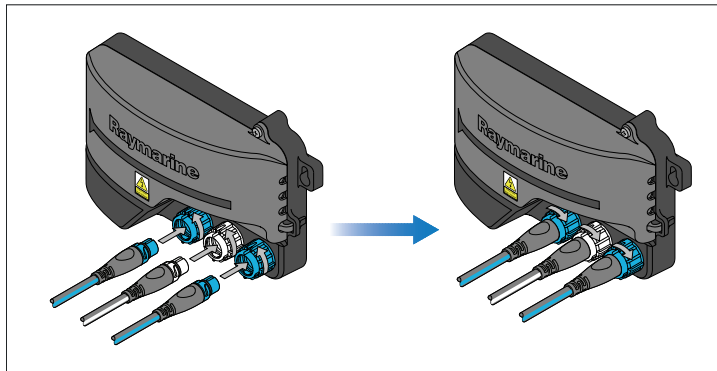

Connecting SeaTalk NG cables

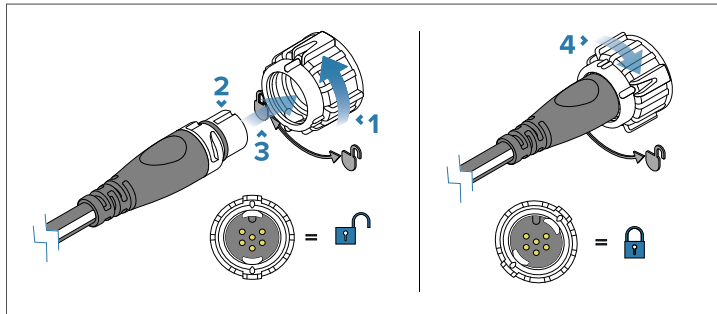

1. Rotate your product's SeaTalk NG connector locking collar counter clockwise, so that the connector is in the unlocked position.

CHAPTER 8: MOUNTING

CHAPTER CONTENTS

- 8.1 Tools required for installation — page 36
- 8.2 Mounting — page 36

8.1 Tools required for installation

Product installation requires the following tools:

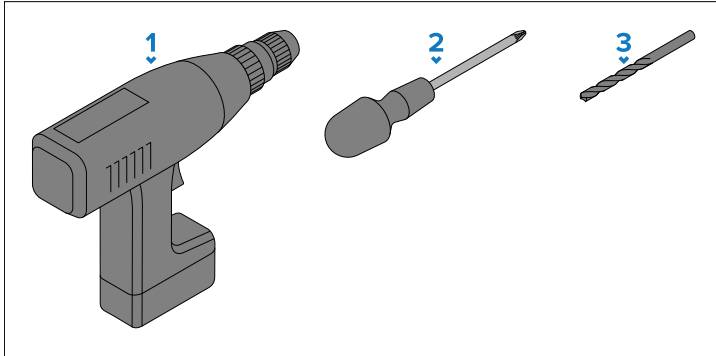

1. Power drill.
2. Pozi drive screwdriver.
3. Drill bit.

Note:

The appropriate drill bit size is dependent on the thickness and material of the mounting surface.

8.2 Mounting

Before mounting the product, ensure that you have:

- Selected a suitable location, based on the location requirements found in this document.
- Identified the relevant cable connections and the route that the cables will take.

Note:

The unit must be mounted horizontally, with the connectors facing outwards.

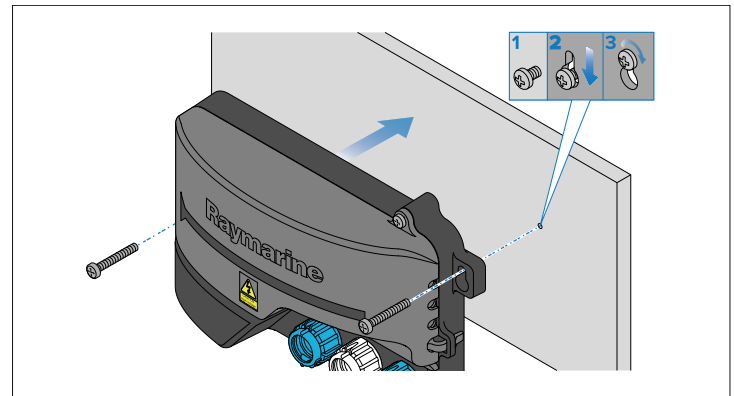

1. Prepare the mounting surface:
 - i. Fix the supplied mounting template to the chosen location, using masking or self-adhesive tape.
 - ii. Drill 2 holes as indicated on the template to accept the fixings.
 - iii. Remove the mounting template.
 - iv. Screw the fixings approximately half way into the holes in the mounting surface.
2. Place the unit over the fixing screws and push the unit downwards to engage the keyhole slots.
3. Fully tighten the screws.
4. Remove the cover:
 - i. Unscrew the front cover retaining screw.
 - ii. Push in the cover clip located on the right hand side.
 - iii. Pull the right hand side of the cover away from the unit slightly.

- iv. Pull the left hand side of the cover away from the unit.
- 5. Route and connect the required transducer cables:

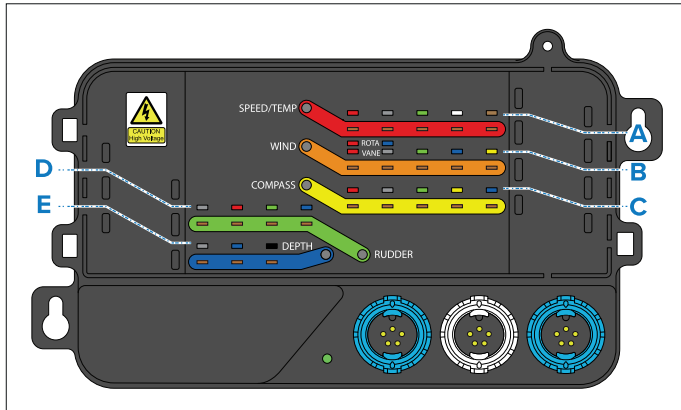

Description	
A	Speed and sea temperature transducer cable guide.
B	Wind transducer / Rotavecta cable guide.
C	Fluxgate compass cable guide.
D	Rudder reference transducer cable guide
E	Depth transducer cable guide.

- 6. Connect the required transducer and SeaTalk NG cables.
- 7. Replace converter cover, ensuring that the transducer cables are placed into the relevant cable guides / channels, as shown.
- 8. Switch on power supply and check system.

CHAPTER 9: TRANSDUCER CONNECTIONS

CHAPTER CONTENTS

- 9.1 Making transducer connections — page 39
- 9.2 Transducer cable lengths — page 39
- 9.3 Transducer connections — page 39

9.1 Making transducer connections

Follow the steps listed below to connect the transducer cables to your iTC-5 converter:

1. Ensure power supply is switched off.
2. Crimp / solder 1/8th (4 mm (0.16 in)) female spade terminals to the end of each wire on the transducer cable, ensuring that no wire is exposed.
3. Unscrew the cover retention screw.
4. Remove the cover.
5. Connect spade terminals as shown in the following section:
[p.38 — Transducer connections](#)
6. Ensure spade terminals are fully pushed home and that terminals do not touch.
7. Secure each cables into its respective run / channel.
8. Refit the cover and re-tighten the cover retention screw.
9. Switch on the power supply.



Warning: iTC-5 High voltage

Do NOT touch exposed transducer wires whilst the converter is powered on and the cover is open or removed.

9.2 Transducer cable lengths

The table below shows the cable lengths supplied with each analog transducer type.

Analog transducer type	Cable length
Speed and temperature:	14 m (45.93 ft).
Wind:	30 m (98.43 ft) / 50 m (164.04 ft).
Rotavecta:	20 m (65.62 ft).
Fluxgate compass:	9.1 m (29.86 ft).
Rudder reference:	9.1 m (29.86 ft).
Depth:	9 m (28.86 ft) / 14 m (45.93 ft) / 20 m (65.62 ft).

Note:

Do not extend transducer cable lengths.

9.3 Transducer connections

The iTC-5 allows up to 5 analog transducers to be connected to your SeaTalk NG network.

Transducers must be installed in accordance with the instructions provided with the transducer.

The following sections provide 6 different example scenarios, which may be applicable when connecting your specific transducer to the iTC-5:

1. [p.39 — Analog Depth, Speed and Temperature \(DST\) transducer connections](#)
2. [p.40 — Analog speed and temperature transducer connections](#)
3. [p.41 — Analog wind vane transducer connections](#)
4. [p.41 — Analog rotavecta transducer connections](#)
5. [p.41 — Analog fluxgate compass transducer connections](#)
6. [p.42 — Analog rudder reference transducer connections](#)
7. [p.42 — Analog depth transducer connections](#)

Note:

For a list of compatible transducers, refer to:
[p.15 — Compatible analog transducers overview](#)

Analog Depth, Speed and Temperature (DST) transducer connections

Analog Depth, Speed and Temperature (DST) transducers can be connected to the iTC-5 via the following connection method. **Additional care must be taken to ensure that the screen connection is correctly wired.**

When connecting a Depth, Speed and Temperature (DST) transducer to an iTC-5, only one screen connection is required. This **must** be made to the **Depth** terminal on the iTC-5. In this configuration, the screen on the Speed / Temp terminal must remain disconnected:

Important:

Do NOT bridge or connect together the screen connections on the iTC-5 Depth and Speed / Temp terminals.

Note:

If the cable is too thick to fit into the iTC-5 cable guides / channels, strip-back the cable sleeve to expose more wire. Then make the connection and apply heat shrink to any portion of the wire that is exposed outside of the iTC-5 casing.

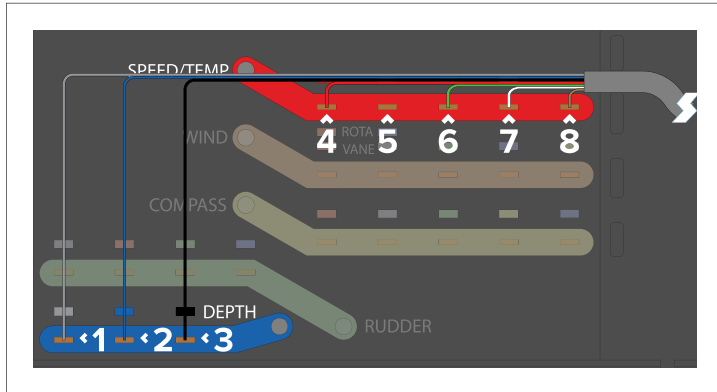

Cable color	Signal name	
1	Screen	0V (shield)
2	Blue	Piezoceramic +
3	Black	Piezoceramic -
4	Red	Speed V+
5	Do NOT connect the screen on the Speed / Temp terminal.	Do NOT connect the screen on the Speed / Temp terminal.
6	Green	Speed (signal)
7	White	Temperature (signal)
8	Brown	Temperature 0V

Analog speed and temperature transducer connections

Compatible analog speed and temperature transducers can be connected to the iTC-5, via the following connection method.

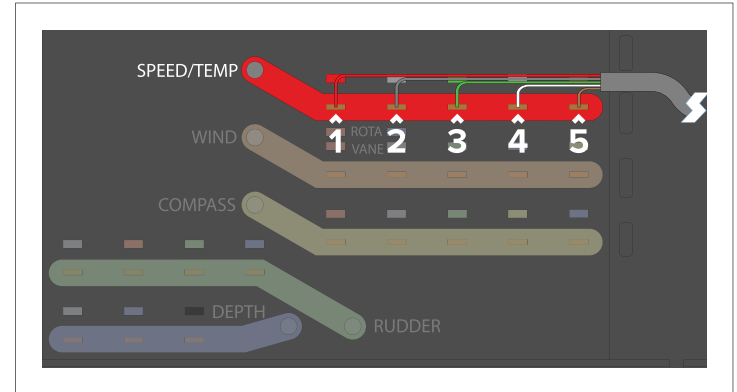

Wire color connection	Signal name	
1	Red	Speed V+
2	Screen	Speed 0V (shield)
3	Green	Speed (signal)
4	White	Temperature (signal)
5	Brown	Temperature 0V

Analog wind vane transducer connections

Compatible analog wind vane transducers can be connected to the iTC-5 via the following connection method.

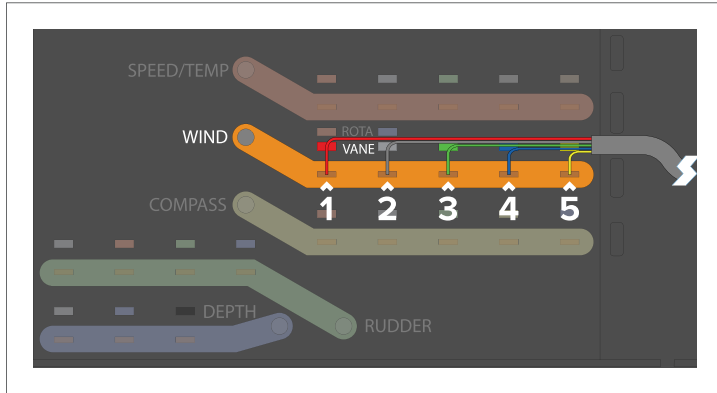

	Wire color connection	Signal name
1	Red	Wind V+
2	Screen	Wind 0V (shield)
3	Green	Sine wind direction
4	Blue	Cosine wind direction
5	Yellow	Anemometer (signal)

Analog rotavecta transducer connections

Compatible analog rotavecta transducers can be connected to the iTC-5 via the following connection method.

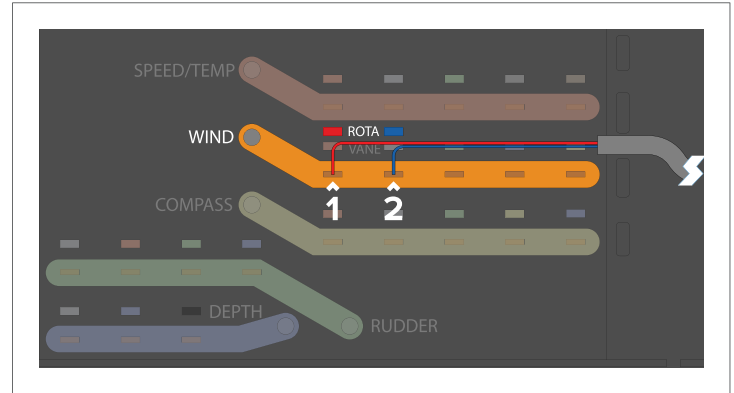

	Wire color connection	Signal name
1	Red	Rotor +
2	Blue	Rotor -

Analog fluxgate compass transducer connections

Compatible analog fluxgate compass transducers can be connected to the iTC-5 via the following connection method.

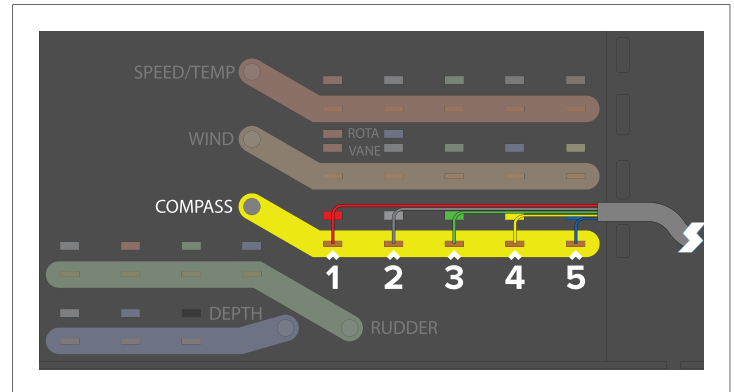

	Wire color connection	Signal name
1	Red	V ref
2	Screen	0V (shield)
3	Green	Sense B
4	Yellow	Sense A
5	Blue	Drive

Analog rudder reference transducer connections

Compatible analog rudder reference transducers can be connected to the iTC-5 via the following connection method.

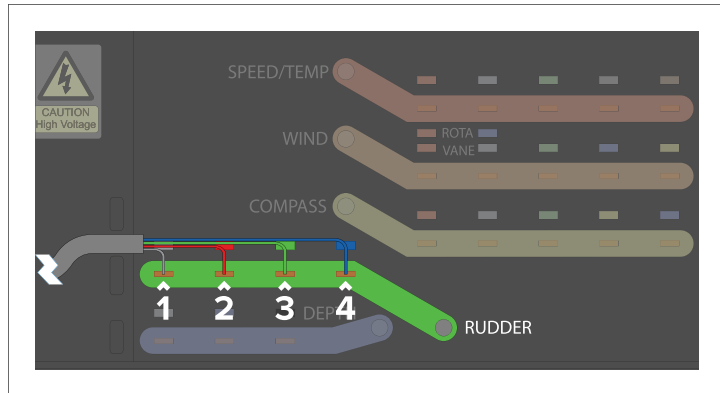

	Wire color connection	Signal name
1	Screen	0V (shield)
2	Red	V+
3	Green	0V
4	Blue	Rudder (signal)

Analog depth transducer connections

Compatible depth transducers can be connected to the iTC-5 via the following connection method.

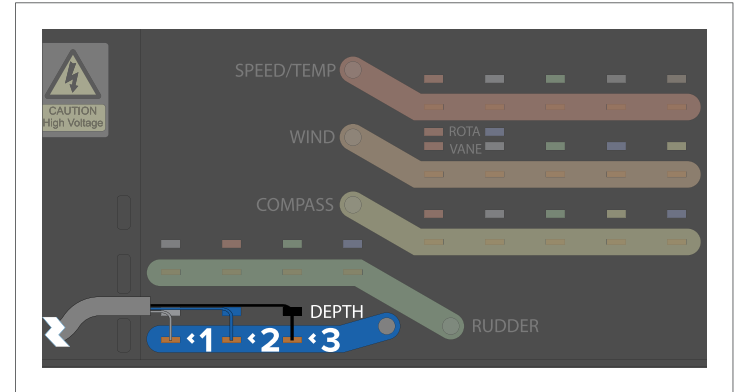

	Cable color	Signal name
1	Screen	0V (shield)
2	Blue	Piezoceramic +
3	Black	Piezoceramic -

CHAPTER 10: POWER CONNECTIONS

CHAPTER CONTENTS

- 10.1 SeaTalk NG power supply — page 44
- 10.2 Inline fuse requirement — page 44
- 10.3 Inline fuse and thermal breaker ratings — page 44
- 10.4 12 Volt dc only — page 45
- 10.5 SeaTalk NG power cables — page 45
- 10.6 SeaTalk NG power cable extension — page 45
- 10.7 SeaTalk NG product loading — page 46
- 10.8 SeaTalk NG power connection point — page 46
- 10.9 SeaTalk NG system loading — page 46
- 10.10 Power distribution — SeaTalk NG — page 47
- 10.11 12 Volt dc only — page 49
- 10.12 Positive ground systems — page 49
- 10.13 Product grounding — page 49
- 10.14 Power connection via Autopilot Control Unit (ACU-Series) — page 49

10.1 SeaTalk NG power supply

Your product is supplied power via the SeaTalk NG backbone (or the NMEA 2000 backbone if applicable).

A SeaTalk NG backbone requires a single 12 V dc power supply. Power can be supplied to the SeaTalk NG backbone by one of the following methods:

- ⁽¹⁾ Direct connection to a 12 V dc battery using an inline 5 amp fuse.
- Connection to a 12 V dc distribution panel using a 3 amp thermal breaker.
- ⁽²⁾ Connection to the SeaTalk NG connector of an ACU-Series Autopilot Control Unit (not ACU-100 or ACU-150), or an SPX-Series course computer (not SPX-5).
- For 24 V vessels, connection must be via a 5 amp, regulated, continuous 24 V dc to 12 V dc converter.

Note:

- ⁽¹⁾ The battery used for starting the vessel's engine(s) should NOT be used to power the SeaTalk NG backbone, as this can cause sudden voltage drops when the engines are started.
- ⁽²⁾ The ACU-100, ACU-150 or SPX-5 cannot be used to power the SeaTalk NG backbone.
- The course computer SeaTalk NG connector includes a power switch that must be in the On position to provide power to the backbone.

10.2 Inline fuse requirement

If your product is NOT supplied with an inline fuse (whether separately or fitted to the power cable), you MUST fit a suitably-rated inline fuse to your product's red power wire, housed in a waterproof fuse holder.

The illustration below shows the two main types of inline fuse with waterproof holder, for use in marine electronics installations. Fuses in a variety of ratings are widely available at chandleries and marine electrical retailers.

Select one of the following fuse types to protect your product:

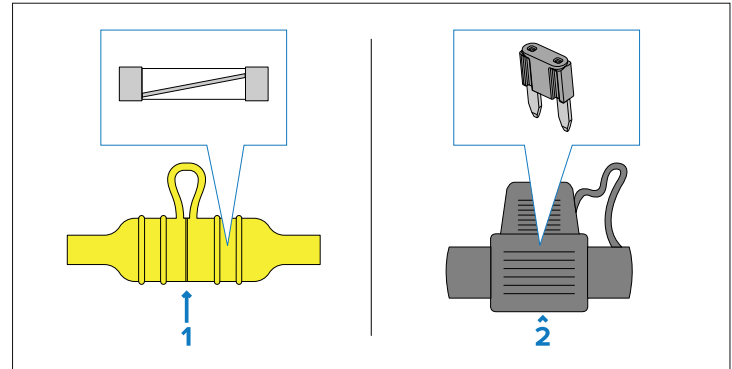

1. Waterproof fuse holder containing a “glass”-type inline fuse.
2. Waterproof fuse holder containing a “blade”-type inline fuse.

Fuse ratings:

- *Voltage rating* — must be equal to or greater than the voltage of your vessel's power supply.
- *Current rating* — refer to the *Inline fuse and thermal breaker rating* section in this document.

10.3 Inline fuse and thermal breaker ratings

The SeaTalk NG network's power supply requires a suitably-rated inline fuse or thermal breaker to be fitted.

Inline fuse rating	Thermal breaker rating
5A	3A (refer to note below)

Note:

The suitable fuse rating for the thermal breaker is dependent on:

1. How many devices you have connected to your SeaTalk NG network, and;
2. How many devices are sharing the same thermal breaker that your SeaTalk NG network is connected to.

10.4 12 Volt dc only

This product must **ONLY** be connected to a 12 V dc power source.

10.5 SeaTalk NG power cables

The following SeaTalk NG power cables can be used to connect the backbone to your chosen **12 V dc** power supply:

Direct connection cables

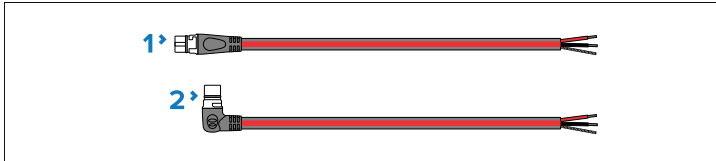

1. Standard (straight) SeaTalk NG power cable, 2 m (6.6 ft) (part number: **A06049**).
2. Elbow (right-angled) SeaTalk NG power cable, 2 m (6.6 ft) (part number: **A06070**).

Wiring

- **+ Red (positive) wire** — connects to the battery or distribution panel positive terminal. A waterproof fuse holder with 5 A inline fuse (not supplied) must be fitted to this red wire.
- **- Black (negative) wire** — connects to battery or distribution panel negative terminal.
- **Drain wire** — connects to the vessel's RF common ground point (if available), or the battery's negative (-) terminal.

Autopilot Control Unit connection cable



1. ACU-Series/SPX-Series autopilot to SeaTalk NG spur cable, 0.3 m (1.0 ft) (part number **R12112**). Connects the course computer to the SeaTalk NG backbone. This connection can also be used to provide 12 V dc power to the SeaTalk NG backbone.

10.6 SeaTalk NG power cable extension

If you need to extend the length of the SeaTalk NG power cable, ensure you observe the following advice:

- Ensure that any extensions of the SeaTalk NG power cable are of a sufficient gauge for the supply voltage, the total current load of the device, and the length of the cable run — as the cable run length increases, the greater the voltage drop will be from one end of the power cable to the other.
- Refer to the following table for typical **minimum** power cable wire gauges:

Cable length in meters (feet)	Wire gauge in AWG (mm ²) for 12 V supply
<8 (<25)	16 (1.31 mm ²)
16 (50)	14 (2.08 mm ²)
24 (75)	12 (3.31 mm ²)
>32 (>100)	10 (5.26 mm ²)

Important:

Be aware that some products in your system (such as sonar modules) can create voltage peaks at certain times, which may impact the voltage available to other products during the peaks.

Important:

To ensure power cables (including any extension) are of a sufficient gauge, ensure that there is a continuous **minimum** voltage of **10.8 V dc** at the end of the SeaTalk NG power cable where it enters the SeaTalk NG backbone, even with a fully flat battery at 11 V dc. (Do not assume that a flat battery is at 0 V dc. Due to the discharge profile and internal chemistry of batteries, the current drops much faster than the voltage. A “fully flat” battery still shows a positive voltage, even if it doesn't have enough current to power your device.)

10.7 SeaTalk NG product loading

The number of products that can be connected to a SeaTalk NG backbone depends on the current draw of each product and the physical length of the backbone cabling.

NMEA 2000 Load Equivalency Numbers (LEN) are used to express the amount of current that is drawn from SeaTalk NG products (**1 LEN = 50 mA**). The LEN for each product can be found in the product's *Technical Specification*.

Products which have a dedicated power supply connection and are connected to the SeaTalk NG backbone will still have an LEN rating. This is because the product's NMEA 2000 / SeaTalk NG internal transceiver will still be powered by the SeaTalk NG backbone.

LENs are used to determine the power connection point for the SeaTalk NG backbone.

10.8 SeaTalk NG power connection point

The point along the backbone where the power connection should be made is based on the length of the backbone.

Note:

- A 12 V dc power supply must be connected to a *white* spur SeaTalk NG connection on the backbone.
- Do NOT connect the power connection to a *blue* SeaTalk NG backbone connector.
- **With the exception of** the iTC-5 and the backbone itself, do NOT connect the power supply directly to a product's *white* SeaTalk NG spur connector.

Small systems

If the backbone length is 60 m (197 ft) or less, the power connection may be made at any point in the backbone.

Large systems

If the backbone length is greater than 60 m (197 ft), the power connection should be made at a point that creates a balanced current draw from each side of the backbone. Load Equivalency Numbers (LEN) are used to determine the power connection point for the system.

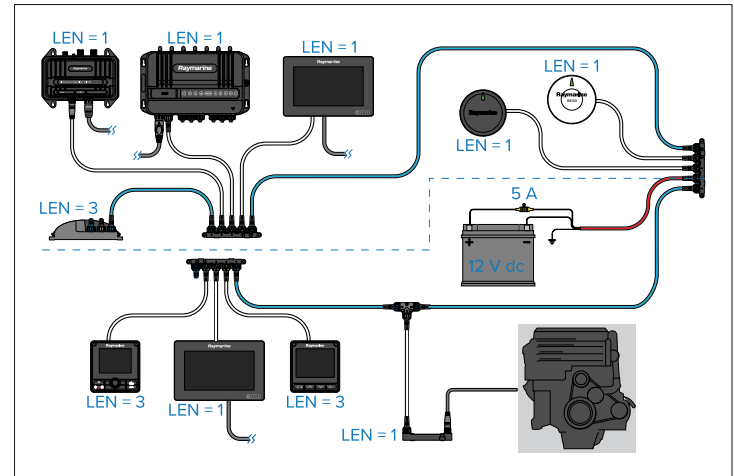

In the example above, the system has an overall LEN of 16, so the optimum connection point would be to have a loading of 8 LEN either side of the connection point.

10.9 SeaTalk NG system loading

The maximum loading (LEN) for a SeaTalk NG system depends on the length of the backbone.

Unbalanced system loading:

- **Backbone Length:** 0 m (0 ft) to 20 m (66 ft) — **Maximum LEN:** 40
- **Backbone Length:** > 20 m (66 ft) to 40 m (131 ft) — **Maximum LEN:** 20
- **Backbone Length:** > 40 m (131 ft) to 60 m (197 ft) — **Maximum LEN:** 14

Balanced system loading:

- **Backbone Length:** 0 m (0 ft) to 60 m (197 ft) — **Maximum LEN:** 100
- **Backbone Length:** > 60 m (197 ft) to 80 m (262 ft) — **Maximum LEN:** 84
- **Backbone Length:** > 80 m (262 ft) to 100 m (328 ft) — **Maximum LEN:** 60
- **Backbone Length:** > 100 m (328 ft) to 120 m (394 ft) — **Maximum LEN:** 50

- **Backbone Length:** > 120 m (394 ft) to 160 m (525 ft) — **Maximum LEN:** 40
- **Backbone Length:** > 160 m (525 ft) to 200 m (656 ft) — **Maximum LEN:** 32

10.10 Power distribution — SeaTalk NG

Recommendations and best practice.

- Only use approved SeaTalk NG power cables. Do NOT use a power cable designed for, or supplied with, a different product.
- See below for more information on implementation for some common power distribution scenarios.

Important:

- When planning and wiring, take into consideration other products in your system, some of which (e.g. sonar modules) may place large power demand peaks on the vessel's electrical system, which may impact the voltage available to other products during the peaks.
- The information provided below is for guidance only, to help protect your product. It covers common vessel power arrangements, but does NOT cover every scenario. If you are unsure how to provide the correct level of protection, please consult an authorized Raymarine dealer or a suitably qualified professional marine electrician.

Implementation — connection to distribution panel (recommended)

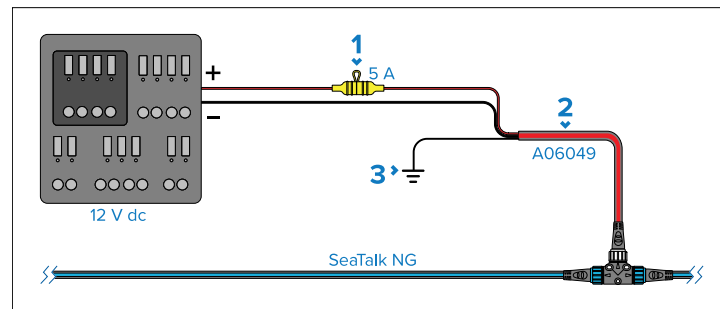

1. Waterproof fuse holder with 5 A inline fuse must be fitted (not supplied).
 2. SeaTalk NG power cable.
 3. RF Ground connection point for drain wire.
- Ideally, the SeaTalk NG power cable should be connected to a suitable breaker or switch on the vessel's distribution panel or factory-fitted power distribution point. It is recommended that a 5 A inline fuse is fitted to the red (positive) wire of the SeaTalk NG power cable.
 - The distribution point should be fed from the vessel's primary power source by 8 AWG (8.36 mm²) cable.
 - Ideally, all equipment should be wired to individual suitably-rated thermal breakers or fuses, with appropriate circuit protection. Where this is not possible and more than one item of equipment shares a breaker, use individual in-line fuses for each power circuit to provide the necessary protection.

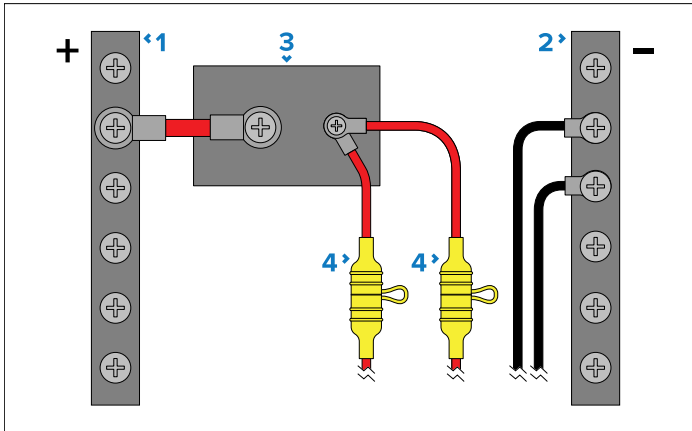

1. Positive (+) bar
2. Negative (-) bar
3. Circuit breaker
4. Waterproof fuse holder with 5 A inline fuse must be fitted (not supplied).

Important:

Observe the recommended fuse / breaker ratings provided in the product's documentation, however be aware that the suitable fuse / breaker rating is dependent on the number of devices being connected.

Implementation — direct connection to battery

- Where connection to a power distribution panel is not possible, the power cable may be connected to the vessel's battery.
- You **MUST** fit a 5 A inline fuse between the red wire and the battery's positive terminal.
- If you need to extend the length of the power cable, ensure you use suitably rated cable and that sufficient power (12 V dc) is available at the SeaTalk NG backbone's power connection.

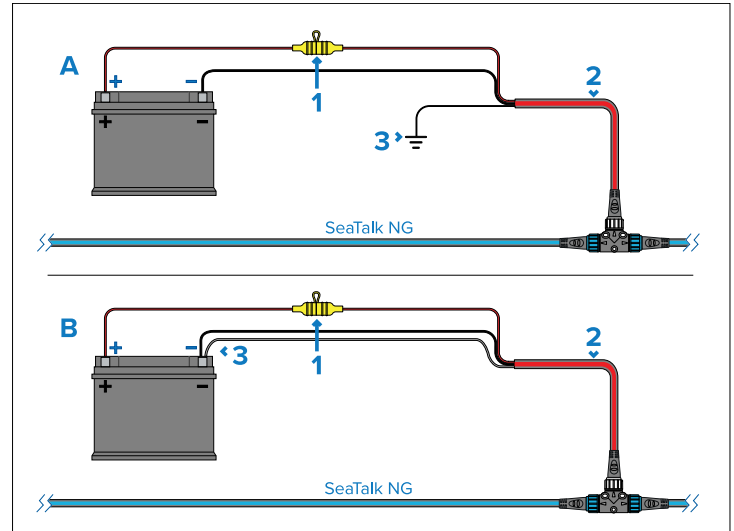

1. Waterproof fuse holder with 5 A inline fuse must be fitted (not supplied).
2. SeaTalk NG power cable.
3. Connection point for drain wire.

Battery connection scenario A:

Suitable for a vessel with a common RF ground point. In this scenario, the power cable's drain wire should be connected to the vessel's common RF ground point.

Battery connection scenario B:

Suitable for a vessel without a common RF ground point. In this scenario the power cable's drain wire should be connected directly to the battery's negative terminal.

SeaTalk NG Power cable extension

If you need to extend the length of the SeaTalk NG power cable, ensure you use suitably-rated cable, and that sufficient power is available at the SeaTalk NG backbone's power connection point:

- For power cable extensions, a **minimum** wire gauge of 16 AWG (1.31 mm²) is recommended. For cable runs longer than 15 m (49.2 ft), you may need to consider a thicker wire gauge (e.g. 14 AWG (2.08 mm²), or 12 AWG (3.31 mm²).

- To ensure power cables (including any extension) are of a sufficient gauge, ensure that there is a continuous **minimum** voltage of **10.8 V dc** at the end of the cable where it enters the product's power connector, even with a fully flat battery at 11 V dc. (Do not assume that a flat battery is at 0 V dc. Due to the discharge profile and internal chemistry of batteries, the current drops much faster than the voltage. A "fully flat" battery still shows a positive voltage, even if it doesn't have enough current to power your device.)

Important:

Be aware that some products in your system (such as sonar modules) can create voltage peaks at certain times, which may impact the voltage available to other products during the peaks.

More information

It is recommended that best practice is observed in all vessel electrical installations, as detailed in the following standards:

- BMEA Code of Practice for Electrical and Electronic Installations in Boats
- NMEA 0400 Installation Standard
- ISO 13297: Small craft — Electrical systems — Alternating and direct current installations
- ISO 10133: Small craft — Electrical systems — Extra-low-voltage d.c. installations
- ABYC E-11 AC & DC Electrical Systems on Boats
- ABYC A-31 Battery chargers and Inverters
- ABYC TE-4 Lightning Protection

10.11 12 Volt dc only

This product must **ONLY** be connected to a 12 V dc power source.

10.12 Positive ground systems

Do **NOT** connect this unit to a system which has positive grounding.

10.13 Product grounding

Important safety information for connections to ground.

Before applying power to this product, it **MUST** be correctly grounded, in accordance with the instructions provided.

10.14 Power connection via Autopilot Control Unit (ACU-Series)

The SeaTalk NG backbone can be supplied 12 V dc power from a compatible Raymarine Autopilot Control Unit (ACU-Series).

Important:

The SeaTalk NG backbone must have a single power supply connection. If your SeaTalk NG backbone is supplied power directly from a battery or distribution panel, then you must ensure that the SeaTalk NG power switch on your ACU-Series is switched Off.

Note:

ACU-100, ACU-150 and SPX-5 autopilot control units cannot supply power to the SeaTalk NG backbone.

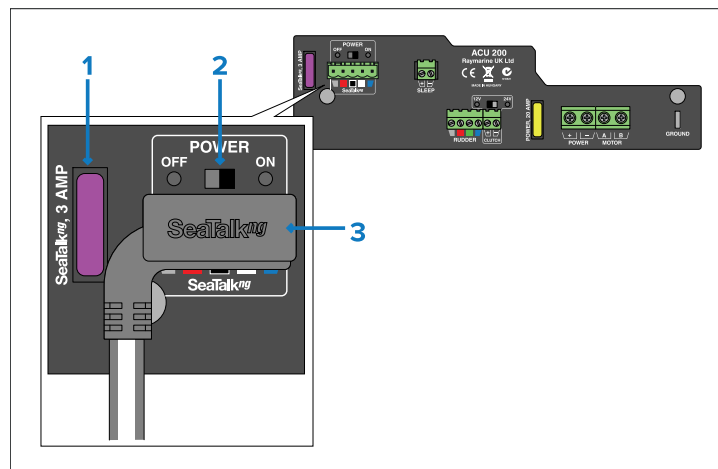

1. Fuse for SeaTalk NG power supply.
2. Power switch for SeaTalk NG power supply:
 - a. Select the *[OFF]* position if your SeaTalk NG backbone is supplied power directly from a battery or distribution panel.
 - b. Select the *[ON]* position if your SeaTalk NG backbone is supplied power by the ACU-Series.
3. ACU-Series/SPX-Series autopilot to SeaTalk NG spur cable (part number: R12112).

CHAPTER 11: SYSTEM CALIBRATION

CHAPTER CONTENTS

- 11.1 Transducer calibration compatibility — page 52
- 11.2 Transducer calibration incompatibility — page 52
- 11.3 Serial number location — page 52

11.1 Transducer calibration compatibility

The following types of transducers can be calibrated when connected to a compatible display via an iTC-5.

Compatible display	Transducer types
LightHouse MFD / chartplotter (running LightHouse 3, v3.11.42 or later, or LightHouse 4, v4.1.65 or later):	<ul style="list-style-type: none"> • <i>Depth transducers (analog).</i> • <i>Speed transducers (analog).</i> • <i>Wind transducers (analog).</i>
i70 / i70s:	<ul style="list-style-type: none"> • <i>Depth transducers (analog).</i> • <i>Speed and temperature transducers (analog).</i> • <i>Wind transducers (analog).</i> • <i>Fluxgate compass transducers (analog).</i> • <i>Rudder reference transducers (analog).</i>
iT70 / iT70+:	<ul style="list-style-type: none"> • <i>Depth transducers (analog).</i> • <i>Speed and temperature transducers (analog).</i> • <i>Wind transducers (analog).</i>

Note:

For instructions on how to calibrate your transducer, refer to the latest operation instructions provided with your display.

11.2 Transducer calibration incompatibility

The following displays cannot be used to calibrate transducers connected via an iTC-5.

Incompatible display	Transducer types
ST40 / i40 / i50 / i60 / ST60+:	<i>Not compatible.</i>

11.3 Serial number location

Each iTC-5 converter has a unique serial number. The serial number is stated on a label, located on the top side of the converter.

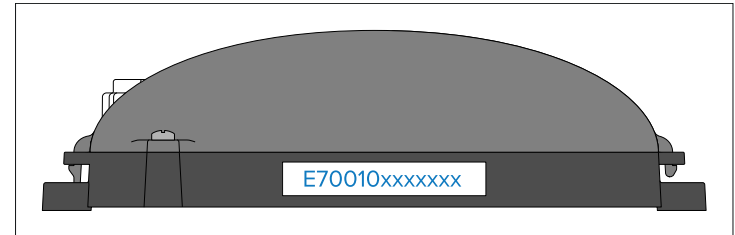

The serial number is required for calibration purposes and must be retained.

Spare serial number labels are provided in the box, which can be placed at your discretion.

CHAPTER 12: SYSTEM CHECKS AND TROUBLESHOOTING

CHAPTER CONTENTS

- 12.1 Troubleshooting — page 54
- 12.2 Typical system checks — page 54
- 12.3 LED diagnostic guidance — page 54
- 12.4 LED Diagnostics — page 55
- 12.5 Power up troubleshooting — page 59
- 12.6 System data troubleshooting — page 60

12.1 Troubleshooting

The troubleshooting section provides possible causes and the corrective action required for common problems that are associated with the installation and operation of your product.

Before packing and shipping, all products are subjected to comprehensive testing and quality assurance programs. If you do experience problems with your product, this section will help you to diagnose and correct problems to restore normal operation.

If after referring to this section you are still having problems with your product, please refer to the *Technical support and servicing* section of this manual for useful links and contact details.

12.2 Typical system checks

After connection of the iTC-5 converter, it is advisable to perform checks on the converter and all connected transducers, before powering the system and first use.

Typical system checks should include:

- **Converter LED status check** — If functioning correctly, the converter status LED should be on.
- **Transducer calibration settings check** — Ensure that transducer data (e.g. wind, speed, temperature, depth, etc.) is accurate and available at all appropriate displays and instruments.
- **Transducer LED status check** — If transducers are not functioning correctly, remove the converter's front cover to access the transducer LED status indicator.
- **Autopilot check** — Check that the autopilot operates as expected and that heading and rudder information is available at all appropriate displays and instruments.

Note:

On autopilot systems, the rudder reference and fluxgate compass should be connected directly to the course computer.

All checks should be performed in a safe and familiar environment, and in accordance with the instructions supplied with each product.

12.3 LED diagnostic guidance

Your product has diagnostic LEDs which can be used to identify the unit's status and to help troubleshoot any potential issues that may occur.

The following section provides two basic examples of how to interpret the LED diagnostic patterns included in this publication.

Example solid LED diagnostic pattern:

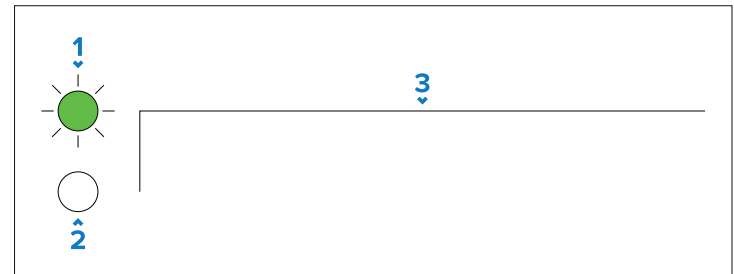

1. **LED ON** — Indicates the color assigned to the unit's diagnostic LED, and confirms that the diagnostic LED is active (switched **on**).
2. **LED OFF** — Indicates that the unit's diagnostic LED is inactive (switched **off**).
3. **Diagnostic pattern** — Indicates a diagnostic pattern based on the number and duration of *peaks* (indicating LED is switched **on**) and *troughs* (indicating LED is switched **off**) generated within the duration of the diagnostic pattern. In the example shown above, a continuous peak occurs, indicating that the LED is permanently **on**.

Example flashing LED diagnostic pattern:

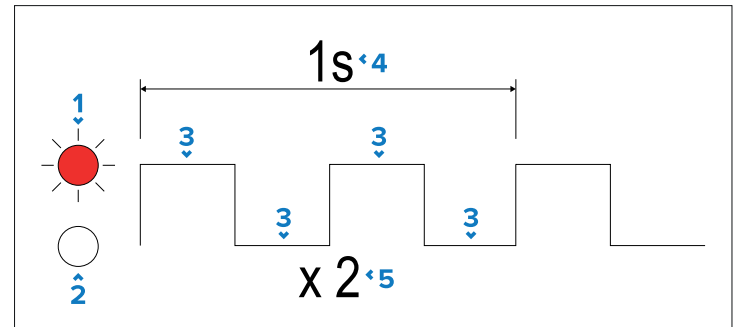

1. **LED ON** — Indicates the color assigned to the unit's diagnostic LED, and confirms that the diagnostic LED is active (switched **on**).
2. **LED OFF** — Indicates that the unit's diagnostic LED is inactive (switched **off**).
3. **Diagnostic pattern** — Indicates a diagnostic pattern based on the number and duration of *peaks* (indicating LED is switched **on**) and *troughs* (indicating LED is switched **off**) generated within the duration of the diagnostic pattern. In the example shown above, a peak followed by a trough occurs and then repeats again, indicating that the LED flashes twice within a period of one second.
4. **Diagnostic pattern duration** — Indicates the total duration of the diagnostic pattern.
5. **Diagnostic pattern flash total** — Indicates the total number of flashes that occur within the diagnostic pattern.

12.4 LED Diagnostics

Your product has diagnostic LEDs which can be used to identify the unit's status and to help troubleshoot any potential issues that may occur.





In order to view the transducer LED status indicators, you need to open the top cover of the converter. For information on how to remove the front cover, refer to: [p.36 — Mounting](#)

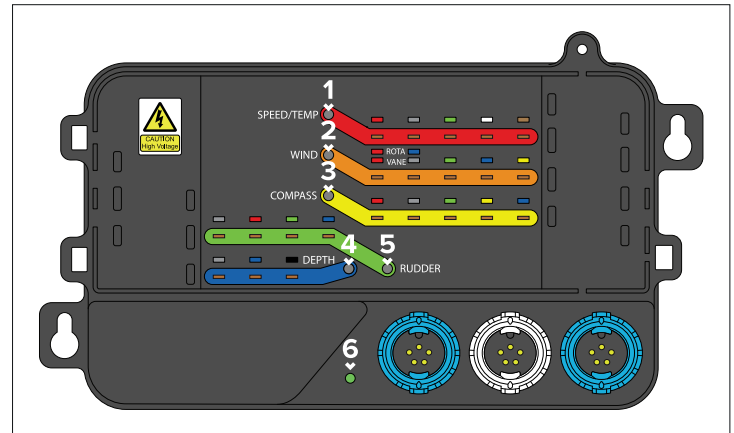

Important:

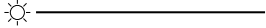
Do not touch exposed transducer wires whilst the converter is powered on and the cover is open.

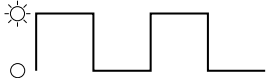

Transducer LEDs (1–5):

LED Indication	LED Status and applicable solutions
 	Powered up / Ok: Normal operation — no user action is required.
 	No power: <ul style="list-style-type: none"> • Check the unit's connector for broken or bent pins. • Check the cable and connectors for signs of damage or corrosion, replace if necessary. • With the unit turned on, try flexing the power cable to see if this causes the unit to re-boot/lose power, replace if necessary.

LED Indication	LED Status and applicable solutions
 	(Speed and temperature / Wind vane transducer only) Vessel speed pulse time-out: <ul style="list-style-type: none"> • Check that the transducer has been installed in accordance with the instructions provided with the transducer. • Check the unit's connector for broken or bent pins. • Check the cable and connectors for signs of damage or corrosion, replace if necessary. • With the unit turned on, try flexing the power cable to see if this causes the unit to re-boot/lose power, replace if necessary. • Check the cable junction box (usually located at the bottom of the mast) for damage and corrosion, and ensure that connections are clean and secure. Repair and replace as necessary. • (Wind vane only) Disconnect the wind vane arm and check arm and base connectors for damage and corrosion. Ensure that they are clean and secure, and repair and replace as necessary.

LED Indication

LED Status and applicable solutions

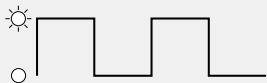

(Depth transducer LED only) Searching for lock:

- Check that the transducer has been installed in accordance with the instructions provided with the transducer.
- If the transducer angle is too great the beam can miss the bottom, adjust transducer angle and recheck.
- If the transducer has a kick-up mechanism, check that it has not kicked up due to hitting an object.
- Check transducer condition, ensuring it is not damaged and is free from debris/fouling. If necessary, clean or replace your transducer. After cleaning or replacement coat the transducer using a water-based anti-fouling paint.
- Consider contacting your local dealer or Raymarine® Product Support. For Raymarine® Product Support contact details, refer to the following section: [p.65 – Raymarine product support and servicing](#)

LED Indication

LED Status and applicable solutions



Lost valid signal:

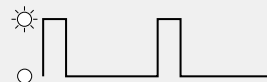

- Check the unit's connector for broken or bent pins.
- Check that the cable connector is fully inserted into the unit and that the locking collar is in the locked position.
- Check the cable and connectors for signs of damage or corrosion, replace if necessary.
- With the unit turned on, try flexing the power cable near to the display connector to see if this causes the unit to re-boot/lose power, replace if necessary.



Not connected:

- Check the unit's connector for broken or bent pins.
- Check that the cable connector is fully inserted into the unit and that the locking collar is in the locked position.
- Check the cable and connectors for signs of damage or corrosion, replace if necessary.
- Consider contacting your local dealer or Raymarine® Product Support. For Raymarine® Product Support contact details, refer to the following section: [p.65 – Raymarine product support and servicing](#)

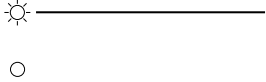
SeaTalk NG LED (6):

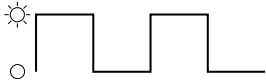
LED Indication	LED Status and applicable solutions
	<p>Powered up / Ok: Normal operation — no user action is required.</p>
	<p>No power: Refer to the advice found within the following section: p.59 — Power up troubleshooting</p>
	<p>Software download: Normal operation — no user action is required.</p>

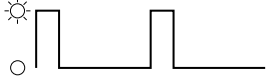
LED Indication	LED Status and applicable solutions
	<p>Low bus voltage:</p> <ul style="list-style-type: none"> • Check the unit's connector for broken or bent pins. • Check that the cable connector is fully inserted into the unit and that the locking collar is in the locked position. • Check the cable and connectors for signs of damage or corrosion, replace if necessary. • With the unit turned on, try flexing the power cable to see if this causes the unit to re-boot/lose power, replace if necessary. • Check the vessel's battery voltage and the condition of the battery terminals and power supply cables, ensuring connections are secure, clean and free from corrosion. Replace if necessary. • With the product under load, using a multi-meter, check for high voltage drop across all connectors / fuses etc, and replace if necessary.
	<p>No communications / fault:</p> <ul style="list-style-type: none"> • Consider contacting your local dealer or Raymarine® Product Support. For Raymarine® Product Support contact details, refer to the following section: p.65 — Raymarine product support and servicing

12.5 Power up troubleshooting

Product does not turn on or keeps turning off

Possible causes	Possible solutions
Blown fuse / tripped breaker	<ol style="list-style-type: none"> 1. Check condition of the SeaTalk NG backbone power connection 5 A fuse and, if applicable, distribution panel breaker; replace if necessary. 2. If the fuse keeps blowing, check for cable damage, broken connector pins, or incorrect wiring.
Poor / damaged / insecure power supply cable / connections	<ol style="list-style-type: none"> 1. Check the vessel's battery voltage and the condition of the battery terminals and power supply cables, ensuring connections are secure, clean and free from corrosion. Replace if necessary. 2. Check the SeaTalk NG power cable and power supply connection for signs of damage or corrosion, and replace if necessary. 3. Check the SeaTalk NG backbone cabling and connectors for signs of damage or corrosion, and replace if necessary. 4. Check the SeaTalk NG power, backbone and product spur cable connectors are correctly orientated, fully inserted into the spur connectors, and in the locked position. 5. With the product turned on, try flexing the product's spur cable near to the product's connector to see if this causes the product to restart or lose power. Replace if necessary. 6. With the product under load, using a multi-meter, check for high voltage drop

Possible causes	Possible solutions
	across all connectors / fuses etc, and replace if necessary.
Incorrect power connection	<ol style="list-style-type: none"> 1. The power supply may be wired incorrectly; ensure that the SeaTalk NG power connection instructions have been followed and that the backbone has only one single source of 12 V dc power.

Product will not start up (restart loop)

Product causes	Possible solutions
Power supply and connection	<ol style="list-style-type: none"> 1. Refer to 'Product does not turn on or keeps turning off' information above.
Software corruption	<ol style="list-style-type: none"> 1. In the unlikely event that the product's software has become corrupted, try downloading and installing the latest software from the Raymarine website. Refer to your MFD/Chartplotter operation instructions for details on updating software for SeaTalk NG devices. 2. Consider contacting your local dealer or Raymarine® Product Support. For Raymarine® Product Support contact details, refer to the following section: p.65 — Raymarine product support and servicing

12.6 System data troubleshooting

Aspects of the installation can cause problems with the data shared between connected equipment. Such problems, their possible causes and solutions are described here.

Note:

For troubleshooting purposes, iTC-5 and SeaTalk NG bus data can be recorded and viewed via a LightHouse 4 MFD / Chartplotter. For more information, refer to the LightHouse 4 Operation Instructions (81406).

Transducer, instrument, engine or other system data is unavailable at all displays

Possible causes	Possible solutions
Data is not being received at the display.	<ol style="list-style-type: none"> 1. Check the relevant product and or network cabling and connections (e.g. SeaTalk NG backbone) for signs of damage or corrosion, and replace if necessary.
Data source (e.g. instrument display or engine interface) is not operating.	<ol style="list-style-type: none"> 1. Check the source of the missing data (e.g. transducer or engine interface) for signs of damage or corrosion, and replace if necessary. 2. If possible, check that the data source is correctly powered and operational. 3. Refer to the instructions provided with the equipment to ensure it has been correctly installed.
Software mismatch between equipment may prevent communication.	<ol style="list-style-type: none"> 1. Ensure all products have the latest software installed.

Transducer, instrument or other system data is missing from some but not all displays

Possible causes	Possible solutions
Connection problem.	<ol style="list-style-type: none"> 1. Check the product's SeaTalk NG spur cable and connections for signs of damage or corrosion, and replace if necessary.
Software corruption.	<ol style="list-style-type: none"> 1. In the unlikely event that the product's software has become corrupted, try downloading and installing the latest software from the Raymarine website. refer to your MFD / Chartplotter operation instructions for details on updating software for SeaTalk NG devices. 2. Consider contacting your local dealer or Raymarine® Product Support. For Raymarine® Product Support contact details, refer to the following section: p.65 — Raymarine product support and servicing
Software mismatch between equipment may prevent communication.	<ol style="list-style-type: none"> 1. Ensure all products have the latest software installed.

Incorrect data reported

Possible causes	Possible solutions
Transducer calibration error.	<ol style="list-style-type: none"> 1. Switch off power supply to system and switch back on again. 2. Re-calibrate or re-configure data source following the instructions provided with the relevant devices.

CHAPTER 13: MAINTENANCE

CHAPTER CONTENTS

- 13.1 Service and maintenance — page 62
- 13.2 Routine checks — page 62
- 13.3 Unit cleaning instructions — page 62

13.1 Service and maintenance

This product contains no user serviceable components. Please refer all maintenance and repair to authorized Raymarine dealers. Unauthorized repair may affect your warranty.

13.2 Routine checks

The following periodic checks should be made:

- Examine cables for signs of damage, such as chafing, cuts or nicks.
- Check that the cable connectors are firmly attached and that their locking mechanisms are properly engaged.

Note:

Cable checks should be carried out with the power supply switched off.



Warning: ITC-5 High voltage

Do NOT touch exposed transducer wires whilst the converter is powered on and the cover is open or removed.

13.3 Unit cleaning instructions

The unit does not require regular cleaning. However, if you find it necessary to clean the unit, please follow the steps below:

1. Ensure power is switched off.
2. Wipe unit clean with a damp cloth.
3. If necessary, use a mild detergent solution to remove grease marks.

Transducer cleaning

You must clean your transducer regularly to remove organic growth. Organic growth can build up quickly on the bottom face of your transducer; this can impact transducer performance in a matter of weeks.

To prevent the build up of sea growth, coat the transducer with a thin layer of water based antifouling paint, available from your local marine dealer. Reapply paint every 6 months or at the beginning of each boating season. Certain smart transducers have restrictions on where antifouling paint is applied. Please consult your dealer.

Note:

- Transducers with a temperature sensor may not work properly if painted.
- Never use ketone based paint. Ketones can attack many plastics possibly damaging the sensor.
- Never use spray paint on your transducer. Spraying incorporates tiny air bubbles, and a marine transducer cannot transmit properly through air.

Important:

- When cleaning growth from an anti-fouled transducer, take care not to let paint dust and other debris enter the water, as this can have an impact on aquatic life.
- Take care not to scratch the surface of the transducer as this can impact transducer performance.
- Do NOT use harsh cleaning solvents such as acetone as this will damage the transducer.

Follow the guidance below to clean growth from your transducer:

- use a soft cloth and a mild household cleaning detergent to clean mild growth build up.
- use a scouring pad, such as a green Scotch Brite™ pad and a mild household cleaning detergent to clean moderate growth build up.
- you may need to use a fine grade wet and dry paper and a mild household cleaning detergent to clean severe build up. Be careful to avoid scratching the transducers face.

- If your transducer has a paddlewheel you can wet sand with fine grade wet/dry paper.
- Harsh cleaning solvents such as acetone may damage the transducer.

Re-applying anti-fouling paint

If you have applied anti-fouling paint to your transducer, it is important to re-apply it at least every 6 months, to maintain effectiveness.

Follow the instructions below to re-apply anti-fouling paint.

Important:

- Following environmental best practice, preparation and re-application of the anti-fouling paint should be performed using suitable washdown facilities, which ensures paint particles do not enter the water and impact aquatic life.
- Take care not to scratch the transducer face, as this may impact transducer performance.

1. Remove your vessel from the water.
2. Clean your transducer, ensuring all organic growth is removed.
3. Remove any flaking anti-foul paint.
4. Use a soft dry cloth to remove any loose bits of paint.
5. Re-apply a water-based anti-fouling paint.

CHAPTER 14: TECHNICAL SUPPORT

CHAPTER CONTENTS

- 14.1 Raymarine technical support and servicing — page 65
- 14.2 Diagnostic product information — page 66
- 14.3 Learning resources — page 66

14.1 Raymarine technical support and servicing

Raymarine provides a comprehensive product support service, as well as warranty, service, and repairs. You can access these services through the Raymarine website, telephone, and e-mail.

Product information

If you need to request service or support, please have the following information to hand:

- Product name.
- Product identity.
- Serial number.
- Software application version.
- System diagrams.

Servicing and warranty

Raymarine offers dedicated service departments for warranty, service, and repairs.

Visit the Raymarine website to **read the latest warranty policy**, and **register** your product's warranty online:

- www.bit.ly/rym-warranty

United Kingdom (UK), EMEA, and Asia Pacific:

- Web: www.bit.ly/rym-service
- Tel: +44 (0)1329 246 932

United States (US):

- Web: www.bit.ly/rym-service
- Tel: +1 (603) 324 7900

Web support

Please visit the “Support” area of the Raymarine website for:

- **Manuals and Documents** — www.bit.ly/rym-docs
- **Technical support forum** — www.bit.ly/rym-support
- **Software updates** — www.bit.ly/rym-software

Technical support

Telephone and online support

Region	Contact details
All regions	Online support: www.bit.ly/rym-support
United Kingdom (UK) and EMEA	Telephone: +44 (0)1329 246 777 Address: Marine House, Cartwright Drive, Fareham, PO15 5RJ, UK.
United States (US)	Telephone: Tel: +1 (603) 324 7900 (Toll-free: +800 539 5539) Address: 110 Lowell Road, Hudson, NH 03051, USA.
Australia and New Zealand (Raymarine subsidiary)	Telephone: +61 2 8977 0300 Address: Suite 1.01, 26 Rodborough Road, Frenchs Forest, NSW, 2086, Australia.
France (Raymarine subsidiary)	Telephone: +33 (0)1 46 49 72 30 Address: 35 avenue Michel Crépeau, 17000 La Rochelle - France.
Germany (Raymarine subsidiary)	Telephone: +49 40 237 808 0 Address: Atlantic-Haus, Zirkusweg 1, 20359 Hamburg.
Italy (Raymarine subsidiary)	Telephone: +39 02 9945 1001 Address: Via L. Manara 2, 20812 Limbiate (MB), Italy.
Spain (Authorized Raymarine distributor)	Telephone: +34 96 2965 102 Email: sat@azimut.es
Netherlands / Benelux (Authorized Raymarine distributor)	Telephone: +31 (0)26 3614 905 Address: Florijnweg 21G, 6883 JN VELD, Nederland.

Region	Contact details
Sweden (Raymarine subsidiary)	Telephone: +46 (0)317 633 670 Address: Bolshedens Industriväg 18, 427 50 Billdal, Sweden.
Finland (Raymarine subsidiary)	Telephone: +358 (0)207 619 937 Address: Suomalaistentie 1-3, 02270 Espoo, Finland.
Norway (Raymarine subsidiary)	Telephone: +47 692 64 600 Address: Årvollskogen 30, 1529 Moss, Norway.
Denmark (Raymarine subsidiary)	Telephone: +45 437 164 64 Address: Centervej 7, 4600 Køge, Denmark.
Russia (Distributor)	Telephone: Tel: +7 495 788 0508 Email: info@mikstmarine.ru

14.2 Diagnostic product information

Diagnostic product information can be viewed and exported from a Raymarine LightHouse MFD / chartplotter, for supported products networked using RayNet (Ethernet), RJ45, RJ45 (SeaTalk HS) or SeaTalk NG / NMEA 2000 cables.

Diagnostic product information includes technical data related to the connected product, such as serial numbers, network addresses, firmware version numbers, and so on. It is useful for 2 main purposes:

1. Sending detailed product information to the Raymarine product support team, in the event of a problem or fault with your product. The information can be exported to a MicroSD card, and you can then copy the file for the purposes of emailing it to the product support team. For contact details, refer to: [p.64 – Technical support](#)
2. Maintaining detailed off-boat records. This is particularly useful for vessels that have multiple Raymarine products installed.

To view or export diagnostic product information, access the *[Diagnostics]* menu. For instructions on how to access this menu, refer to the relevant *Operation Instructions* for your MFD / chartplotter.

14.3 Learning resources

Raymarine has produced a range of learning resources to help you get the most out of your products.

Video tutorials

Raymarine official channel on YouTube

- <http://www.youtube.com/user/RaymarineInc>

Training courses

Raymarine regularly runs a range of in-depth training courses to help you make the most of your products. Visit the Training section of the Raymarine website for more information:

- www.bit.ly/rym-training

Technical support forum

You can use the Technical support forum to ask a technical question about a Raymarine product or to find out how other customers are using their Raymarine equipment. The resource is regularly updated with contributions from Raymarine customers and staff:

- www.bit.ly/rym-support

CHAPTER 15: TECHNICAL SPECIFICATION

CHAPTER CONTENTS

- 15.1 Physical specification — page 68
- 15.2 Power specification — page 68
- 15.3 Network specification — page 68
- 15.4 Environmental specification — page 68
- 15.5 Conformance specification — page 68

15.1 Physical specification

Specification	
Width:	163.50 mm (6.44 in)
Height:	93.10 mm (3.66 in)
Depth:	44.30 mm (1.74 in)

15.2 Power specification

Specification	
Nominal supply voltage:	12 V dc
Operating voltage range:	9 – 16 V dc
Current:	< 150 mA peak operating current
Power consumption:	Typical: 1.5 W
LEN:	3

15.3 Network specification

Specification	
Data connections:	<ul style="list-style-type: none">• SeaTalk NG backbone• 1 x SeaTalk NG spur• 5 x transducer connections with spade terminals

15.4 Environmental specification

Specification	
Operating temperature range:	-15°C to +55°C (5°F to +131 °F)
Storage temperature range:	-25°C to +70°C (-13 °F to +158 °F)
Relative humidity:	95% Max
Waterproof rating:	Splash proof to IPx2

15.5 Conformance specification

Specification	
Europe:	2004/108/EC
Australia and New Zealand:	C-Tick, Compliance Level 2

CHAPTER 16: SPARES AND ACCESSORIES

CHAPTER CONTENTS

- 16.1 Spares — page 70
- 16.2 SeaTalk NG cables and accessories — page 70

16.1 Spares

The following spares are available for your iTC-5 converter:

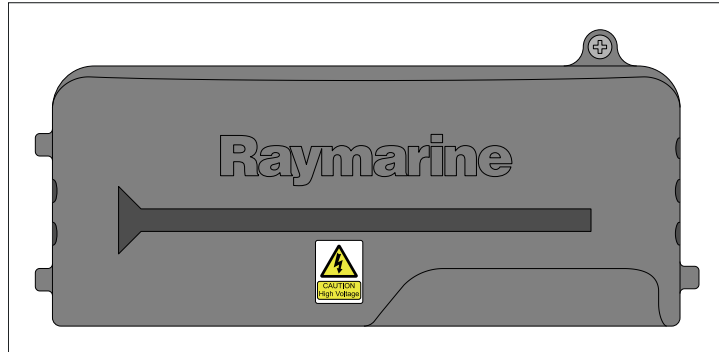

Part	Description
A80002	Spare top cover

16.2 SeaTalk NG cables and accessories

SeaTalk NG cables and accessories for use with compatible products.

SeaTalk NG kits

SeaTalk NG kits enable you to create a simple SeaTalk NG backbone.

Starter kit (part number: T70134) consists of:

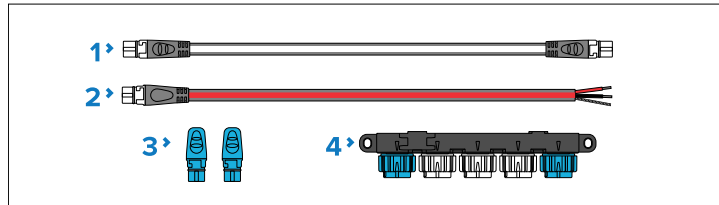

- 1 x Spur cable 3 m (9.8 ft) (part number: **A06040**). Used to connect device to the SeaTalk NG backbone.
- 1 x Power cable 2 m (6.6 ft) (part number: **A06049**). Used to provide 12 V dc power to the SeaTalk NG backbone.

- 2 x Backbone terminators (part number: **A06031**). Terminators must be fitted to both ends of the SeaTalk NG backbone.
- 1 x 5-Way connector (part number: **A06064**). Each connector block allows connection of up to 3 SeaTalk NG devices. Multiple connector blocks can be 'daisy chained' together.

Backbone kit (part number: A25062) consists of:

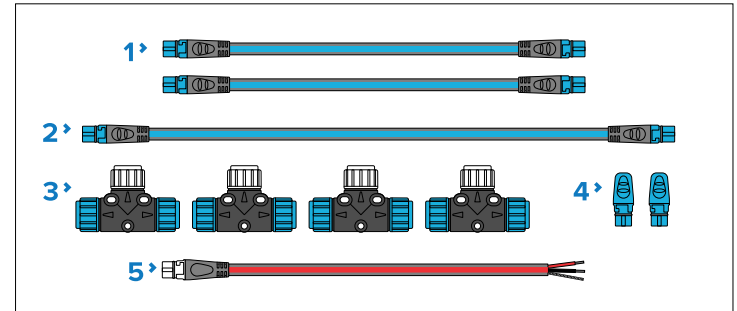

- 2 x Backbone cables 5 m (16.4 ft) (part number: **A06036**). Used to create and extend the SeaTalk NG backbone.
- 1 x Backbone cable 20 m (65.6 ft) (part number: **A06037**). Used to create and extend the SeaTalk NG backbone.
- 4 x T-piece (part number: **A06028**). Each T-piece allows connection of one SeaTalk NG device. Multiple T-pieces can be 'daisy chained' together.
- 2 x Backbone terminators (part number: **A06031**). Terminators must be fitted to both ends of the SeaTalk NG backbone.
- 1 x Power cable 2 m (6.6 ft) (part number: **A06049**). Used to provide 12 V dc power to the SeaTalk NG backbone.

Evolution-Series autopilot cable kit (part number: R70160) consists of:

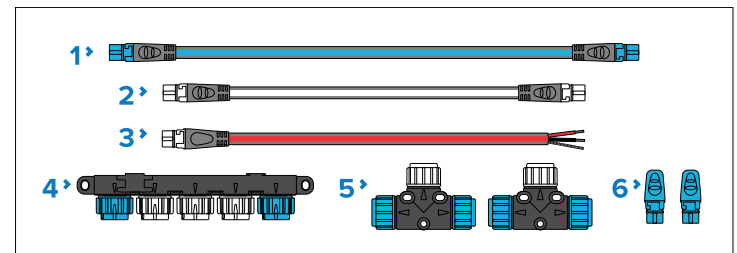

- 1 x Backbone cable 5 m (16.4 ft) (part number: **A06036**). Used to create and extend the SeaTalk NG backbone.
- 1 x Spur cable 1 m (3.3 ft) (part number: **A06040**). Used to connect device to the SeaTalk NG backbone.
- 1 x Power cable 2 m (6.6 ft) (part number: **A06049**). Used to provide 12 V dc power to the SeaTalk NG backbone.
- 1 x 5-Way connector (part number: **A06064**). Each connector block allows connection of up to 3 SeaTalk NG devices. Multiple connector blocks can be 'daisy chained' together.
- 2 x T-pieces (part number: **A06028**). Each T-piece allows connection of one SeaTalk NG device. Multiple T-pieces can be 'daisy chained' together.
- 2 x Backbone terminators (part number: **A06031**). Terminators must be fitted to both ends of the SeaTalk NG backbone.

SeaTalk 1 to SeaTalk NG converter kit (part number: E22158) consists of:

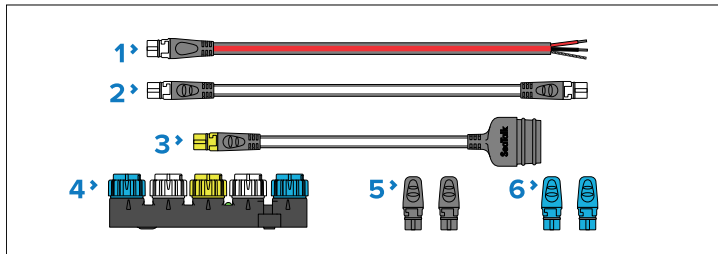

- 1 x Power cable 2 m (6.6 ft) (part number: **A06049**). Used to provide 12 V dc power to the SeaTalk NG backbone.
- 1 x Spur cable 1 m (3.3 ft) (part number: **A06039**). Used to connect a device to the SeaTalk NG backbone.
- 1 x SeaTalk 1 (3 pin) to SeaTalk NG adapter cable 0.4 m (1.3 ft) (part number: **A22164**). Used to connect SeaTalk 1 devices to the SeaTalk NG backbone via the SeaTalk 1 to SeaTalk NG converter.
- 1 x SeaTalk 1 to SeaTalk NG converter (part number: **E22158**). Each converter allows connection of one SeaTalk 1 device and up to 2 SeaTalk NG devices.
- 2 x Spur blanking plugs (part number: **A06032**). Used to cover unused spur connections in 5-way blocks, T-piece connectors and SeaTalk 1 to SeaTalk NG converter.

- 2 x Backbone terminators (part number: **A06031**). Terminators must be fitted to both ends of the SeaTalk NG backbone.

NMEA 0183 VHF 2-wire to SeaTalk NG converter kit (part number: E70196) consists of:

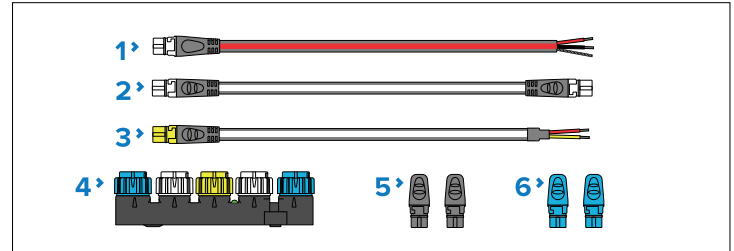

- 1 x Power cable 2 m (6.6 ft) (part number: **A06049**). Used to provide 12 V dc power to the SeaTalk NG backbone.
- 1 x Spur cable 1 m (3.3 ft) (part number: **A06039**). Used to connect a device to the SeaTalk NG backbone.
- 1 x NMEA 0183 VHF stripped-end (2-wire) to SeaTalk NG adapter cable 1 m (3.3 ft) (part number: **A06071**). Used to connect an NMEA 0183 VHF radio to the SeaTalk NG backbone via the NMEA 0183 to SeaTalk NG converter.
- 1 x SeaTalk 1 to SeaTalk NG converter (part number: **E22158**). Each converter allows connection of one SeaTalk 1 device and up to 2 SeaTalk NG devices.
- 2 x Spur blanking plugs (part number: **A06032**). Used to cover unused spur connections in 5-way blocks, T-piece connectors, and the SeaTalk 1 to SeaTalk NG converter.
- 2 x Backbone terminators (part number: **A06031**). Terminators must be fitted to both ends of the SeaTalk NG backbone.

SeaTalk NG spur cables

SeaTalk NG spur cables are required to connect devices to the SeaTalk NG backbone.

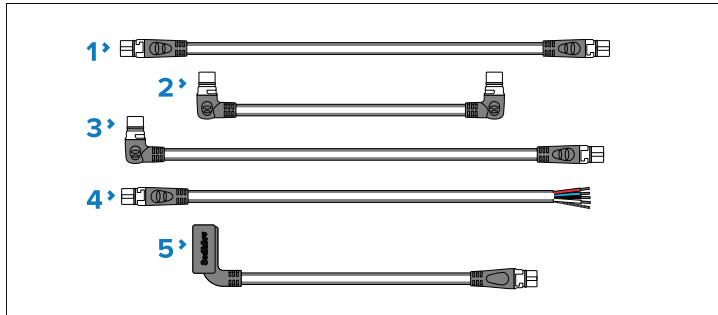

1. SeaTalk NG spur cables:
 - Spur cable 0.4 m (1.3 ft) (part number: **A06038**).
 - Spur cable 1 m (3.3 ft) (part number: **A06039**).
 - Spur cable 3 m (9.8 ft) (part number: **A06040**).
 - Spur cable 5 m (16.4 ft) (part number: **A06041**).
2. Elbow (right-angled) to elbow (right-angled) spur cable 0.4 m (1.3 ft) (part number: **A06042**). Used in confined spaces where a straight spur cable will not fit.
3. Elbow (right-angled) to straight spur cable 1 m (3.3 ft) (part number: **A06081**). Used in confined spaces where a straight spur cable will not fit.
4. SeaTalk NG to stripped-end spur cables (connects compatible products that do not have a SeaTalk NG connector, such as transducer pods):
 - SeaTalk NG to stripped-end spur cable 1 m (3.3 ft) (part number: **A06043**)
 - SeaTalk NG to stripped-end spur cable 3 m (9.8 ft) (part number: **A06044**)
5. ACU-Series / SPX-Series autopilot to SeaTalk NG spur cable 0.3 m (1.0 ft) (part number **R12112**). Connects the course computer to the SeaTalk NG backbone. This connection can also be used to provide 12 V dc power to the SeaTalk NG backbone.

SeaTalk NG backbone cables

SeaTalk NG backbone cables are used to create or extend a SeaTalk NG backbone.

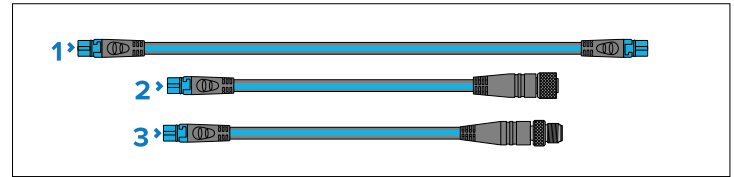

1. Backbone cables:
 - Backbone cable 0.4 m (1.3 ft) (part number: **A06033**).
 - Backbone cable 1 m (3.3 ft) (part number: **A06034**).
 - Backbone cable 3 m (9.8 ft) (part number: **A06035**).
 - Backbone cable 5 m (16.4 ft) (part number: **A06036**).
 - Backbone cable 9 m (29.5 ft) (part number: **A06068**).
 - Backbone cable 20 m (65.6 ft) (part number: **A06037**).
2. SeaTalk NG to DeviceNet (female) Backbone cable 0.4 m (1.3 ft) (part number: **A80675**)
3. SeaTalk NG to DeviceNet (male) Backbone cable 0.4 m (1.3 ft) (part number: **A80674**)

SeaTalk NG power cables

SeaTalk NG power cables are used to provide the SeaTalk NG backbone with a single 12 V dc power source. The power connection must include a 5 amp inline fuse (not supplied).

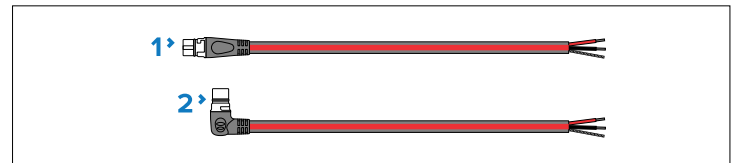

1. Power cable (straight) 2 m (6.6 ft) (part number: **A06049**).
2. Elbow (right-angled) power cable 2 m (6.6 ft) (part number: **A06070**).

SeaTalk NG connectors

SeaTalk NG connectors are used to connect SeaTalk NG devices to the SeaTalk NG backbone and to create and extend the backbone.

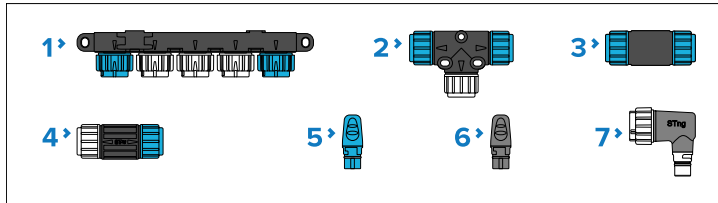

1. 5-Way connector (part number: **A06064**). Each connector block allows connection of up to 3 SeaTalk NG devices. Multiple connector blocks can be 'daisy chained' together.
2. T-piece (part number: **A06028**). Each T-piece allows connection of one SeaTalk NG device. Multiple T-pieces can be 'daisy chained' together.
3. Backbone extender (part number: **A06030**). Used to connect 2 backbone cables together.
4. Inline terminator (part number: **A80001**). Used to connect a spur cable and SeaTalk NG device at the end of a backbone instead of a backbone terminator.
5. Backbone terminator (part number: **A06031**). Terminators must be fitted to both ends of the SeaTalk NG backbone.
6. Spur blanking plug (part number: **A06032**). Used to cover unused spur connections in 5-Way blocks, T-piece connectors, or the SeaTalk 1 to SeaTalk NG converter.
7. Elbow (right-angled) spur connector (part number: **A06077**). Used in confined spaces where a straight spur cable will not fit.

SeaTalk NG adaptors and adaptor cables

SeaTalk NG adaptor cables are used to connect devices designed for different CAN Bus backbones (e.g.: SeaTalk 1 or DeviceNet) to the SeaTalk NG backbone.

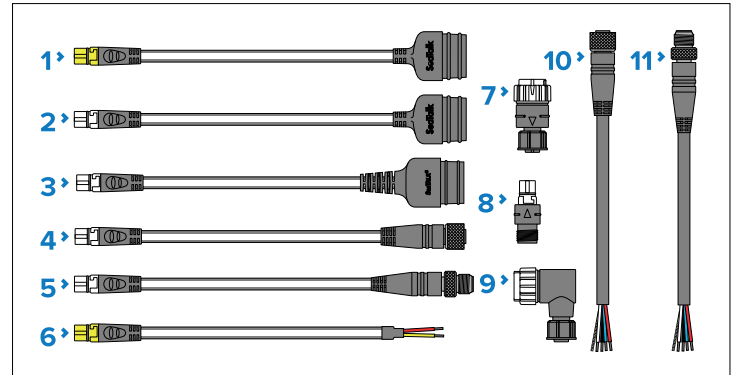

1. SeaTalk 1 (3 pin) to SeaTalk NG converter cable 1 m (3.3 ft) (part number: **A22164 / A06073**). Can be used to connect a SeaTalk 1 device to a SeaTalk NG backbone via the SeaTalk 1 to SeaTalk NG converter, or to connect a SeaTalk NG product directly to a SeaTalk 1 network.
2. SeaTalk 1 (3 pin) to SeaTalk NG adaptor cable 0.4 m (1.3 ft) (part number: **A06047**). Can be used to connect a SeaTalk 1 device to a SeaTalk NG backbone via the SeaTalk 1 to SeaTalk NG converter, or to connect a SeaTalk NG product directly to a SeaTalk 1 network.
3. SeaTalk 2 (5 pin) to SeaTalk NG adaptor cable 0.4 m (1.3 ft) (part number: **A06048**). Used to connect SeaTalk 2 devices or networks to a SeaTalk NG backbone.
4. SeaTalk NG to DeviceNet (female) adaptor cables connect NMEA 2000 devices that use a DeviceNet connector to the SeaTalk NG backbone, or connects SeaTalk NG devices to an NMEA 2000 network. The following cables are available:
 - SeaTalk NG to DeviceNet (female) adaptor cable 0.4 m (1.3 ft) (part number: **A06045**).
 - SeaTalk NG to DeviceNet (female) adaptor cable 1 m (3.3 ft) (part number: **A06075**).
5. SeaTalk NG to DeviceNet (male) adaptor cables. Connect NMEA 2000 devices that use a DeviceNet connector to the SeaTalk NG backbone, or connect SeaTalk NG devices to an NMEA 2000 network. The following cables are available:
 - SeaTalk NG to DeviceNet (male) adaptor cable 0.1 m (0.33 ft) (part number: **A06078**).

- SeaTalk NG to DeviceNet (male) adaptor cable 0.4 m (1.3 ft) (part number: **A06074**).
 - SeaTalk NG to DeviceNet (male) adaptor cable 1 m (3.3 ft) (part number: **A06076**).
 - SeaTalk NG to DeviceNet (male) adaptor cable 1.5 m (4.92 ft) (part number: **A06046**).
6. NMEA 0183 stripped-end (2-wire) to SeaTalk NG adapter cable 1 m (3.3 ft) (part number: **A06071**). Used to connect an NMEA 0183 VHF radio to the SeaTalk NG backbone via the NMEA 0183 to SeaTalk NG converter.
 7. SeaTalk NG (male) to DeviceNet (female) adaptor (**A06082***).
 8. SeaTalk NG (female) to DeviceNet (male) adaptor (**A06083***).
 9. SeaTalk NG (male) to DeviceNet (female) elbow (right-angled) adaptor (**A06084***).
 10. DeviceNet (female) to stripped-end adaptor cable (0.4 m (1.3 ft)) (part number: **E05026**).
 11. DeviceNet (male) to stripped-end adaptor cable (0.4 m (1.3 ft)) (part number: **E05027**).

Important:

* Do NOT connect the A06082, A06083, or A06084 adaptors directly to a backbone. Only connect as part of a **spur** connection between backbone and device.

Appendix A Supported NMEA 2000 PGNs

The iTC-5 converter supports the following NMEA 2000 PGNs.

PGN	Description	Receive	Transmit
59904	ISO request	•	
59392	ISO acknowledge		•
60928	Address claim	•	•
65240	ISO commanded address	•	
126464	Transmission PGN list		•
126464	Received PGN list		•
126996	Product information		•
126208	Acknowledge group function		•
126208	Command group function	•	
126208	Request group function	•	
127245	Rudder		•
128259	Speed, water referenced		•
128267	Depth		•
128275	Distance log		•
130306	Wind data		•
127250	Vessel heading		•

PGN	Description	Receive	Transmit
130310	Environmental parameters		•
130312	Temperature		•

Index

A

Accessories	
SeaTalk NG adaptor cables.....	73
SeaTalk NG backbone cables.....	72
SeaTalk NG cables.....	70
SeaTalk NG connectors	72
SeaTalk NG kits.....	70
SeaTalk NG Power cables	72
SeaTalk NG spur cables.....	71
Anti-fouling	63

B

Backbone length,	
SeaTalk NG.....	46

C

Cable	
Bend radius.....	30
Protection	30–31
Routing	30
Security.....	30
Strain relief.....	30
Cabling	
Circuit isolation	30
Circuit isolation	30
Cleaning.....	62
Compass safe distance	28
Connecting cables	31
Connecting transducer cables	39
Connections	19–20, 31–33
Analog depth.....	42
Analog fluxgate compass	41
Analog rotavecta	41
Analog rudder reference	42
Analog speed and temperature	40
Analog wind vane.....	41
Battery	48
Distribution panel	47

DST.....	39
Power	44, 46, 49
Power connections	
Power distribution.....	47
SeaTalk NG.....	34
system checks	54

D

Declaration of Conformity	9
Diagnostics	54, 66
Exporting product information	66
Viewing product information	66
Distribution panel connection.....	47

E

Electromagnetic Compatibility	10, 27
EMC, <i>See</i> Electromagnetic Compatibility	

F

Fuse requirement	44
------------------------	----

I

Inline fuse	44
Interference.....	28
<i>See also</i> Compass safe distance	
iTC-5 connections.....	33

L

LED diagnostics	55
Load equivalency number.....	46
Location requirements	
General	27

M

Maintenance.....	9, 62
------------------	-------

Mounting	36
----------------	----

N

Network length, SeaTalk NG	46
NMEA 2000 LEN	46

P

Power	
Battery connection	48
Distribution panel	47
Fuses	44
Sharing a breaker	47
Power cable extension	45, 48
Power connection point	46
Power troubleshooting	59
Product documentation	
Applicable documents	13
Related documents	13
Product loading	46
Product recycling (WEEE)	10
Product support	65

R

Routine checks	62
----------------------	----

S

SeaTalk NG	34, 47
Adaptor cables	73
Backbone cables	72
Connectors	72
iTC-5 connections	33
Kits	70
LEN	46
Load equivalency number	46
Power	44, 46, 49
Power cables	45, 72

Spur cables	71
System loading	46
SeaTalk NG cables	70
Service Center	65
Servicing	9, 62
Software version	13
Support forum	66
Suppression ferrites	28, 31
<i>See also</i> EMC	
System diagram	19–20, 31–32

T

Technical specification	
Conformance specification	68
Environmental specification	68
Network specification	68
Physical specification	68
Power specification	68
Technical support	65–66
Tools required	36
Training courses	66
Transducer connections	
Analog depth	42
Analog fluxgate compass	41
Analog rotavecta	41
Analog rudder reference	42
Analog speed and temperature	40
Analog wind vane	41
DST	39
Troubleshooting	54, 66
Diagnostics	54
system checks	54

V

Ventilation	27
-------------------	----

W

Warranty	10, 65
WEEE Directive	10