

# Raymarine®



## RCR-1

### MicroSD CARD READER

#### Installation instructions

English (en-US)  
Date: 10-2020  
Document number: 87396-2  
© 2020 Raymarine UK Limited



## Trademark and patents notice

**Raymarine, Tacktick, Clear Pulse, Truzoom, SeaTalk, SeaTalk<sup>hs</sup>, SeaTalkng**, and **Micronet**, are registered or claimed trademarks of Raymarine Belgium.

**FLIR, DockSense, LightHouse, DownVision, SideVision, RealVision, HyperVision, Dragonfly, Element, Quantum, Axiom, Instalert, Infrared Everywhere, The World's Sixth Sense** and **ClearCruise** are registered or claimed trademarks of FLIR Systems, Inc.

All other trademarks, trade names, or company names referenced herein are used for identification only and are the property of their respective owners.

This product is protected by patents, design patents, patents pending, or design patents pending.

## Fair Use Statement

You may print no more than three copies of this manual for your own use. You may not make any further copies or distribute or use the manual in any other way including without limitation exploiting the manual commercially or giving or selling copies to third parties.

## Software updates



Check the Raymarine website for the latest software releases for your product.  
[www.raymarine.com/software](http://www.raymarine.com/software)

## Product documentation



The latest versions of all English and translated documents are available to download in PDF format from the website: [www.raymarine.com/manuals](http://www.raymarine.com/manuals).  
Please check the website to ensure you have the latest documentation.

## Publication copyright

**Copyright ©2020 Raymarine UK Ltd. All rights reserved.**



# Contents

<b>Chapter 1 Important information .....</b>	<b>7</b>
Water ingress .....	7
Disclaimer .....	7
EMC installation guidelines .....	7
Declaration of Conformity.....	8
Product disposal .....	8
Warranty registration.....	8
IMO and SOLAS .....	9
Technical accuracy.....	9
<b>Chapter 2 Product and system overview.....</b>	<b>11</b>
2.1 Document information.....	12
Product documentation .....	12
2.2 Applicable products.....	12
2.3 Product overview .....	12
Compatible displays .....	12
<b>Chapter 3 Parts supplied.....</b>	<b>13</b>
3.1 Parts supplied.....	14
<b>Chapter 4 Product dimensions.....</b>	<b>15</b>
4.1 Product dimensions .....	16
<b>Chapter 5 Location requirements .....</b>	<b>17</b>
5.1 Switch off power supply .....	18
5.2 Potential ignition source.....	18
5.3 Location requirements.....	18
5.4 EMC installation guidelines.....	18
<b>Chapter 6 Installation .....</b>	<b>19</b>
6.1 Flush mounting.....	20
6.2 Surface mounting.....	21
<b>Chapter 7 Connections .....</b>	<b>23</b>
7.1 General cabling guidance .....	24
Cable types and length.....	24
Cable routing .....	24
Strain relief.....	24
Cable shielding .....	24
Suppression ferrites.....	25
Fitting suppression ferrites .....	25
7.2 Connections overview .....	26
Using the RCR-1 with cartography .....	26
Network connection to multiple MFDs .....	27

<b>Chapter 8 Operation .....</b>	<b>29</b>
8.1 Compatible MicroSD cards .....	30
8.2 Care of MicroSD cards.....	30
8.3 Removing MicroSD card from its adaptor .....	30
8.4 Inserting MicroSD card into reader .....	31
8.5 Removing MicroSD card from reader .....	31
8.6 Using the RCR-1 with cartography.....	31
<b>Chapter 9 Maintenance .....</b>	<b>33</b>
9.1 Service and maintenance.....	34
9.2 Routine equipment checks .....	34
<b>Chapter 10 Technical support.....</b>	<b>35</b>
10.1 Raymarine product support and servicing .....	36
10.2 Learning resources.....	37
<b>Chapter 11 Technical specification.....</b>	<b>39</b>
11.1 Technical specification.....	40
11.2 Compliance.....	40

## Chapter 1: Important information



### Warning: Product installation and operation

- This product must be installed and operated in accordance with the instructions provided. Failure to do so could result in personal injury, damage to your vessel and/or poor product performance.
- Raymarine recommends certified installation by a Raymarine approved installer. A certified installation qualifies for enhanced product warranty benefits. Contact your Raymarine dealer for further details, and refer to the separate warranty document packed with your product.



### Warning: Potential ignition source

This product is NOT approved for use in hazardous/flammable atmospheres. Do NOT install in a hazardous/flammable atmosphere (such as in an engine room or near fuel tanks).



### Warning: Product grounding

Before applying power to this product, ensure it has been correctly grounded, in accordance with the instructions provided.



### Warning: Positive ground systems

Do not connect this unit to a system which has positive grounding.



### Warning: Switch off power supply

Ensure the vessel's power supply is switched OFF before starting to install this product. Do NOT connect or disconnect equipment with the power switched on, unless instructed in this document.

### Caution: Power supply protection

When installing this product ensure the power source is adequately protected by means of a suitably-rated fuse or thermal circuit breaker.

## Water ingress

Water ingress disclaimer

Although the waterproof rating capacity of this product meets the IPX6 standard, water intrusion and subsequent equipment failure may occur if the product is subjected to commercial high-pressure washing. Raymarine will not warrant products subjected to high-pressure washing.

## Disclaimer

Raymarine does not warrant that this product is error-free or that it is compatible with products manufactured by any person or entity other than Raymarine.

Raymarine is not responsible for damages or injuries caused by your use or inability to use the product, by the interaction of the product with products manufactured by others, or by errors in information utilized by the product supplied by third parties.

## EMC installation guidelines

Raymarine equipment and accessories conform to the appropriate Electromagnetic Compatibility (EMC) regulations, to minimize electromagnetic interference between equipment and minimize the effect such interference could have on the performance of your system

Correct installation is required to ensure that EMC performance is not compromised.

**Note:** In areas of extreme EMC interference, some slight interference may be noticed on the product. Where this occurs the product and the source of the interference should be separated by a greater distance.

For **optimum** EMC performance we recommend that wherever possible:

- Raymarine equipment and cables connected to it are:
  - At least 1 m (3.3 ft) from any equipment transmitting or cables carrying radio signals e.g. VHF radios, cables and antennas. In the case of SSB radios, the distance should be increased to 2 m (6.6 ft).
  - More than 2 m (6.6 ft) from the path of a radar beam. A radar beam can normally be assumed to spread 20 degrees above and below the radiating element.
- The product is supplied from a separate battery from that used for engine start. This is important to prevent erratic behavior and data loss which can occur if the engine start does not have a separate battery.
- Raymarine specified cables are used.
- Cables are not cut or extended, unless doing so is detailed in the installation manual.

**Note:**

**Where constraints on the installation prevent any of the above recommendations**, always ensure the maximum possible separation between different items of electrical equipment, to provide the best conditions for EMC performance throughout the installation.

## Declaration of Conformity

FLIR Belgium BVBA declares that the RCR-1, part number A80585, is in compliance with the EMC Directive 2014/30/EU.

The original Declaration of Conformity certificate may be viewed on the relevant product page at [www.raymarine.com/manuals](http://www.raymarine.com/manuals).

## Product disposal

Dispose of this product in accordance with the WEEE Directive.

The Waste Electrical and Electronic Equipment (WEEE) Directive requires the recycling of waste electrical and electronic equipment which contains materials, components and substances that may be hazardous and present a risk to human health and the environment when WEEE is not handled correctly.

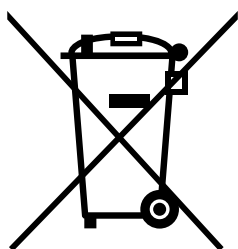

Equipment marked with the crossed-out wheeled bin symbol indicates that the equipment should not be disposed of in unsorted household waste.

Local authorities in many regions have established collection schemes under which residents can dispose of waste electrical and electronic equipment at a recycling center or other collection point.

For more information about suitable collection points for waste electrical and electronic equipment in your region, refer to the Raymarine website: [www.raymarine.eu/recycling](http://www.raymarine.eu/recycling).

## Warranty registration

To register your Raymarine product ownership, please visit [www.raymarine.com](http://www.raymarine.com) and register online.

It is important that you register your product to receive full warranty benefits. Your unit package includes a bar code label indicating the serial number of the unit. You will need this serial number when registering your product online. You should retain the label for future reference.

## **IMO and SOLAS**

The equipment described within this document is intended for use on leisure marine boats and workboats NOT covered by International Maritime Organization (IMO) and Safety of Life at Sea (SOLAS) Carriage Regulations.

## **Technical accuracy**

To the best of our knowledge, the information in this document was correct at the time it was produced. However, Raymarine cannot accept liability for any inaccuracies or omissions it may contain. In addition, our policy of continuous product improvement may change specifications without notice. As a result, Raymarine cannot accept liability for any differences between the product and this document. Please check the Raymarine website ([www.raymarine.com](http://www.raymarine.com)) to ensure you have the most up-to-date version(s) of the documentation for your product.



## Chapter 2: Product and system overview

### Chapter contents

- [2.1 Document information on page 12](#)
- [2.2 Applicable products on page 12](#)
- [2.3 Product overview on page 12](#)

## 2.1 Document information

This document contains important information related to the installation of your Raymarine product. The document includes information to help you:

- plan your installation and ensure you have all the necessary equipment;
- install and connect your product as part of a wider system of connected marine electronics;
- troubleshoot problems and obtain technical support if required.

This and other Raymarine product documents are available to download in PDF format from [www.raymarine.com/manuals](http://www.raymarine.com/manuals).

## Product documentation

The following documentation is applicable to your product:

Description	Part number
Installation instructions	<b>87396</b>
Mounting template	<b>87388</b>

## 2.2 Applicable products

This document applies to the following products:

- A80585 — RCR-1 MicroSD remote card reader

## 2.3 Product overview

The RCR-1 is a remote MicroSD card reader for Axiom MFDs.

The device features a single card slot and can read and write data to a compatible MicroSD card, for the following purposes:

- Update MFD software.
- Import / Export My Data (Waypoints, Routes, Tracks etc).
- Import / Export Settings.
- Install third-party LightHouse app APK files (for install only; apps cannot be run directly from storage device).
- Store and view videos (.mov files).
- Viewing PDF files
- Store and view screenshots or images (.png, .jpg files).

The card reader has a waterproof rating of IPx6 / IPx7 (when lid is closed).

**Note:** Most MicroSD cards are supplied with an adaptor; MicroSD cards must be removed from their adaptors before they can be used in the RCR-1's MicroSD card slot. For more information refer to: [8.3 Removing MicroSD card from its adaptor](#)

## Compatible displays

The RCR-1 card reader is compatible with the following LightHouse™ 3 MFDs.

- Axiom / Axiom+
- Axiom Pro
- Axiom XL

**Note:** MFDs require LightHouse™ 3 software release 3.10 **or later** for Navionics cartography compatibility.

## Chapter 3: Parts supplied

### Chapter contents

- [3.1 Parts supplied on page 14](#)

### 3.1 Parts supplied

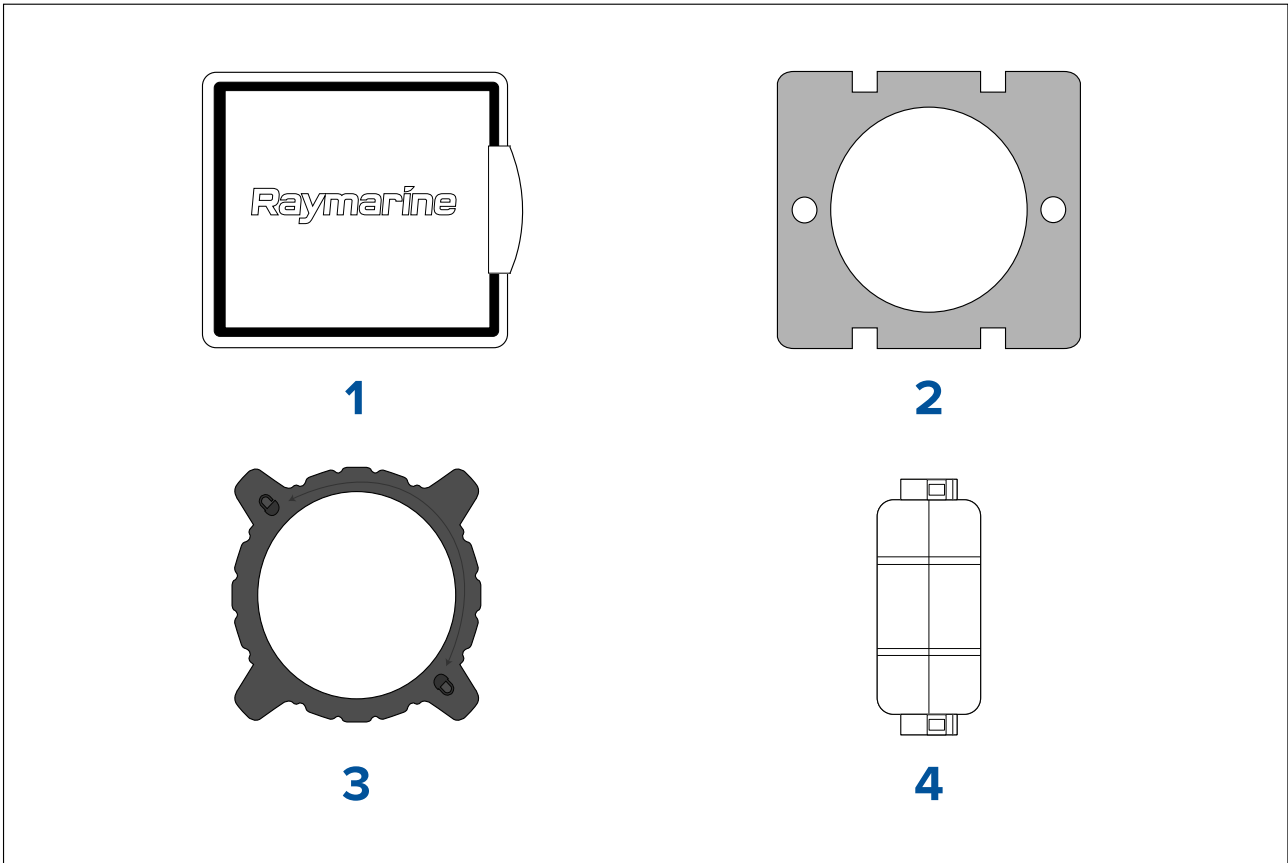

1. 1x RCR-1 microSD card reader, including 1 m (3.28 ft) captive cable.
2. 1x foam gasket.
3. 1x lock ring.
4. 1x suppression ferrite.

## Chapter 4: Product dimensions

### Chapter contents

- [4.1 Product dimensions on page 16](#)

## 4.1 Product dimensions

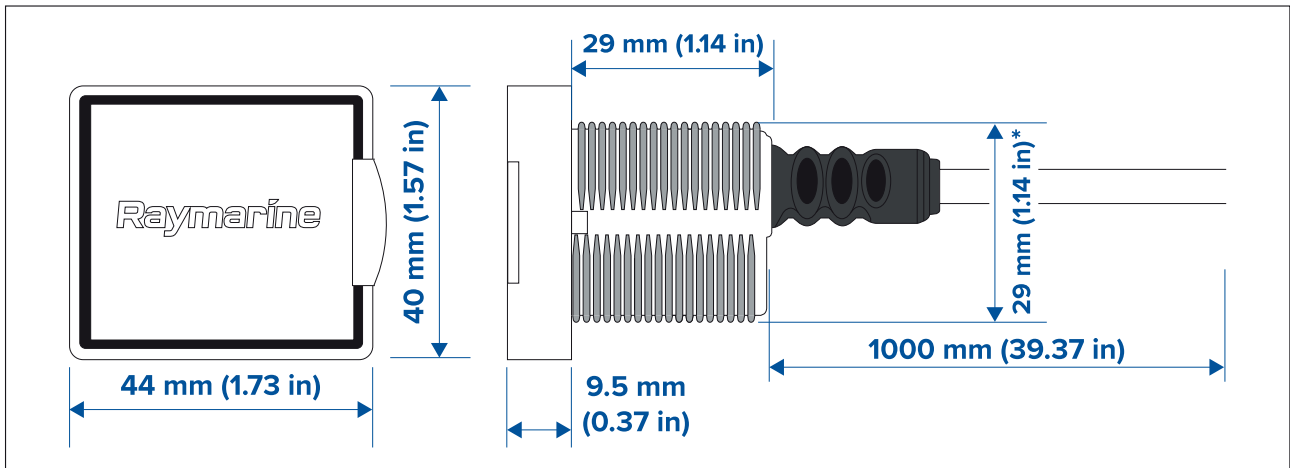

\* 29 mm (1.14 in) diameter cut-out hole required.

## Chapter 5: Location requirements

### Chapter contents

- 5.1 Switch off power supply on page 18
- 5.2 Potential ignition source on page 18
- 5.3 Location requirements on page 18
- 5.4 EMC installation guidelines on page 18

## 5.1 Switch off power supply

Ensure the vessel's power supply is switched OFF before starting to install this product. Do NOT connect or disconnect equipment with the power switched on, unless instructed in this document.

## 5.2 Potential ignition source

This product is NOT approved for use in hazardous/flammable atmospheres. Do NOT install in a hazardous/flammable atmosphere (such as in an engine room or near fuel tanks).

## 5.3 Location requirements

Location considerations.

- Ensure the unit's cable can reach the accessory port of the MFD before mounting.
- To maximise ease of use it is recommended that the unit is mounted in an easy to access location.
- Mount the unit in a location that is protected from physical damage and vibration.
- Ensure the unit is mounted far enough away from equipment or cabling that may cause interference, such as motors, generators, radio transmitters, magnetic compass or power cables.
- Ensure that the cabling is secured at regular intervals to prevent stress on connectors.

### **Important:**

This product is NOT waterproof when the lid is open.

## 5.4 EMC installation guidelines

Raymarine equipment and accessories conform to the appropriate Electromagnetic Compatibility (EMC) regulations, to minimize electromagnetic interference between equipment and minimize the effect such interference could have on the performance of your system

Correct installation is required to ensure that EMC performance is not compromised.

**Note:** In areas of extreme EMC interference, some slight interference may be noticed on the product. Where this occurs the product and the source of the interference should be separated by a greater distance.

For **optimum** EMC performance we recommend that wherever possible:

- Raymarine equipment and cables connected to it are:
  - At least 1 m (3.3 ft) from any equipment transmitting or cables carrying radio signals e.g. VHF radios, cables and antennas. In the case of SSB radios, the distance should be increased to 2 m (6.6 ft).
  - More than 2 m (6.6 ft) from the path of a radar beam. A radar beam can normally be assumed to spread 20 degrees above and below the radiating element.
- The product is supplied from a separate battery from that used for engine start. This is important to prevent erratic behavior and data loss which can occur if the engine start does not have a separate battery.
- Raymarine specified cables are used.
- Cables are not cut or extended, unless doing so is detailed in the installation manual.

### **Note:**

**Where constraints on the installation prevent any of the above recommendations**, always ensure the maximum possible separation between different items of electrical equipment, to provide the best conditions for EMC performance throughout the installation.

## Chapter 6: Installation

### Chapter contents

- [6.1 Flush mounting on page 20](#)
- [6.2 Surface mounting on page 21](#)

## 6.1 Flush mounting

Flush mounting provides a sleek installation where the product and dash are flush. Flush mounting requires the mounting surface to be rebated.

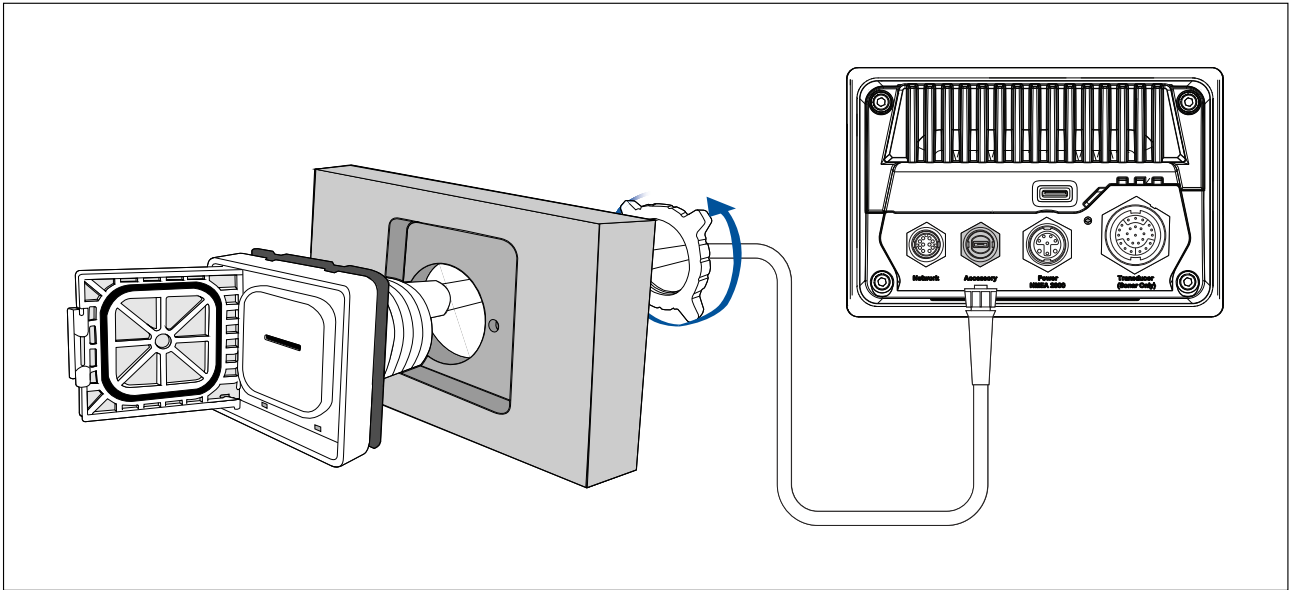

1. Check the selected location for the unit. A clear, flat area with suitable clearance behind the panel is required.
2. Before modifying the mounting surface, refer to the dimensions supplied in this documentation to ensure there is enough space for the unit and all cables.
3. Fix the supplied mounting template (87388) to the selected location, using masking or self adhesive tape.
4. Drill 2 holes as indicated on the mounting template to accept the location lugs.
5. Using a suitable drill or saw, cut out the center hole.
6. Using a Router, follow the Flush mount rebate line, to cut out a rebate to the specified rebate depth, as indicated on the template.

### **Important:**

For CNC machining CAD data is available on the Raymarine website.

7. Ensure that the unit fits into the removed area and then remove rough edges.
8. Attach the gasket to the rear of the card reader.
9. Feed the 1m (3.28 ft) cable through the hole and the lock ring (on the other side of the hole). Connect the cable to the Accessory connection on the rear of your MFD.
10. Insert the card reader into the cut-out hole.
11. Secure the card reader by screwing the lock ring on until the card reader is firmly in place.
12. To prevent water ingress and consequent damage to the product, ensure that the card reader door or cover is firmly closed.

## 6.2 Surface mounting

When surface mounted the product protrudes slightly from the mounting surface, usually by the thickness of the bezel.

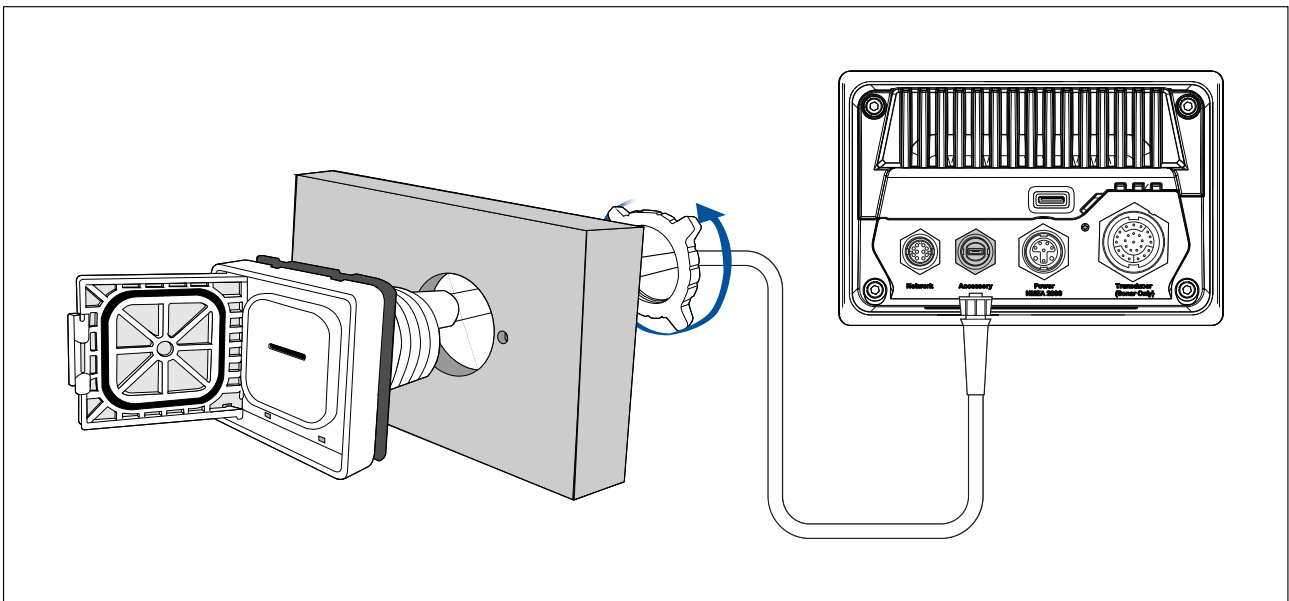

1. Check the selected location for the unit. A clear, flat area with suitable clearance behind the panel is required.
2. Before modifying the mounting surface, ensure there is enough space for the unit and all cables.
3. Fix the supplied mounting template (87388) to the selected location, using masking or self adhesive tape.
4. Drill 2 holes to accept the location lugs, as indicated on the mounting template.
5. Using a suitable drill or saw, cut out the center hole.
6. Ensure that the unit fits into the removed area and then remove rough edges.
7. Attach the gasket to the rear of the card reader.
8. Feed the 1 m (3.28 ft) cable through the hole and the lock ring (on the other side of the hole). Connect the cable to the Accessory connection on the rear of your MFD.
9. Insert the card reader into the cut-out hole.
10. Secure the card reader by screwing the lock ring until the card reader is firmly in place.
11. To prevent water ingress, ensure that the card reader door cover is firmly closed.



## Chapter 7: Connections

### Chapter contents

- [7.1 General cabling guidance on page 24](#)
- [7.2 Connections overview on page 26](#)

## 7.1 General cabling guidance

### Cable types and length

It is important to use cables of the appropriate type and length.

- Unless otherwise stated only use cables supplied by Raymarine.
- Where it is necessary to use non-Raymarine cables, ensure that they are of correct quality and gauge for their intended purpose. (e.g.: longer power cable runs may require larger wire gauges to minimize voltage drop along the run).

### Cable routing

Cables must be routed correctly, to maximize performance and prolong cable life.

- Do NOT bend cables excessively. Wherever possible, ensure a minimum bend diameter ( $\emptyset$ ) of 200 mm (7.87 in) / minimum bend radius (R) of 100 mm (3.94 in).

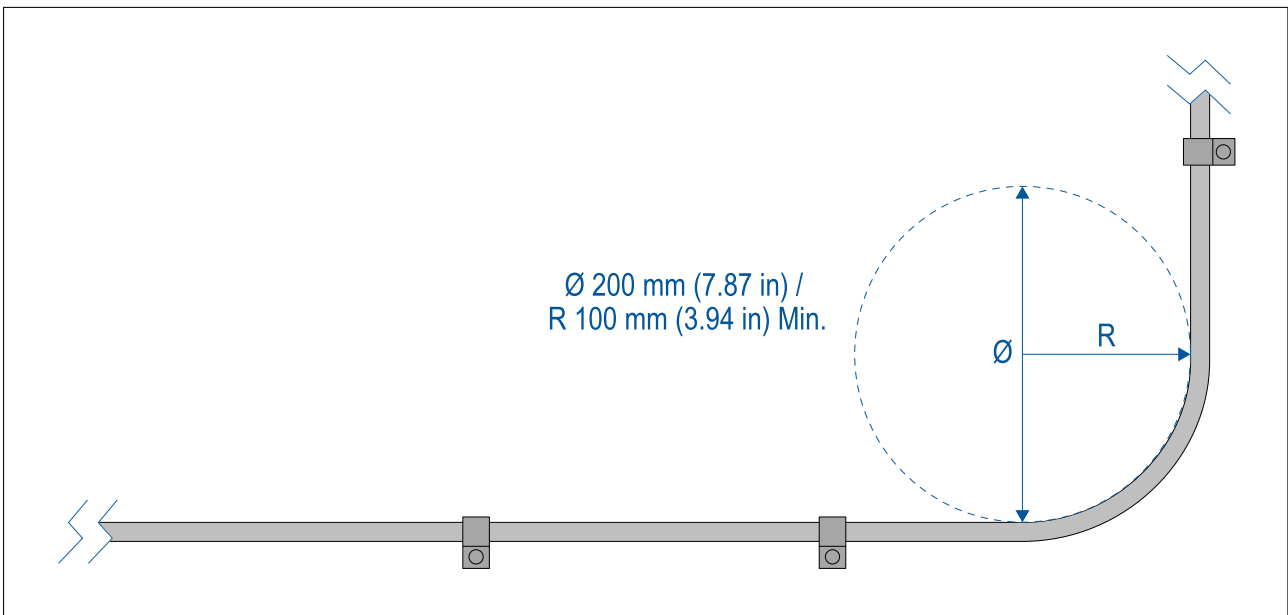

- Protect all cables from physical damage and exposure to heat. Use trunking or conduit where possible. Do NOT run cables through bilges or doorways, or close to moving or hot objects.
- Secure cables in place using cable clips or cable ties. Coil any excess cable and tie it out of the way.
- Where a cable passes through an exposed bulkhead or deckhead, use a suitable watertight feed-through.
- Do NOT run cables near to engines or fluorescent lights.
- Always route data cables as far away as possible from:
  - other equipment and cables,
  - high current carrying AC and DC power lines,
  - antennas.

### Strain relief

Use adequate strain relief for cabling to ensure that connectors are protected from strain and will not pull out under extreme sea conditions.

### Cable shielding

Ensure that cable shielding is not damaged during installation and that all cables are properly shielded.

## Suppression ferrites

- Raymarine cables may be pre-fitted or supplied with suppression ferrites. These are important for correct EMC performance. If ferrites are supplied separately to the cables (i.e. not pre-fitted), you must fit the supplied ferrites, using the supplied instructions.
- If a ferrite has to be removed for any purpose (e.g. installation or maintenance), it must be replaced in the original position before the product is used.
- Use only ferrites of the correct type, supplied by Raymarine or its authorized dealers.
- Where an installation requires multiple ferrites to be added to a cable, additional cable clips should be used to prevent stress on the connectors due to the extra weight of the cable.

## Fitting suppression ferrites

Electromagnetic interference (EMI) from other devices can cause data corruption when reading and writing to external storage via the card reader. The supplied suppression ferrite should be fitted to the card reader's cable to help prevent this.

1. At least one suppression ferrite is required for all installations. The suppression ferrite should be fitted 6 mm (0.24 in) from the end of the connector end of the cable.
2. 3 suppression ferrites are required for installations where the card reader will be used for cartography. Two suppression ferrites should be fitted 6 mm (0.24 in) apart from each other at the connector end of the cable, and one ferrite 53 mm (2.09 in) from the card reader end. For suitable ferrites, refer to your dealer.

**Important:** Raymarine recommends MFD internal card readers are used for cartography wherever possible.

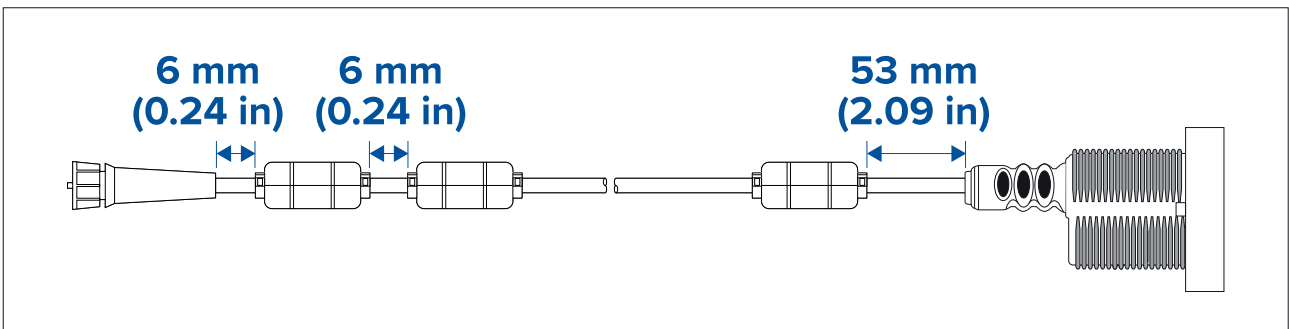

## 7.2 Connections overview

Your card reader connects to the Micro USB accessory port located on the back of your Axiom MFD.

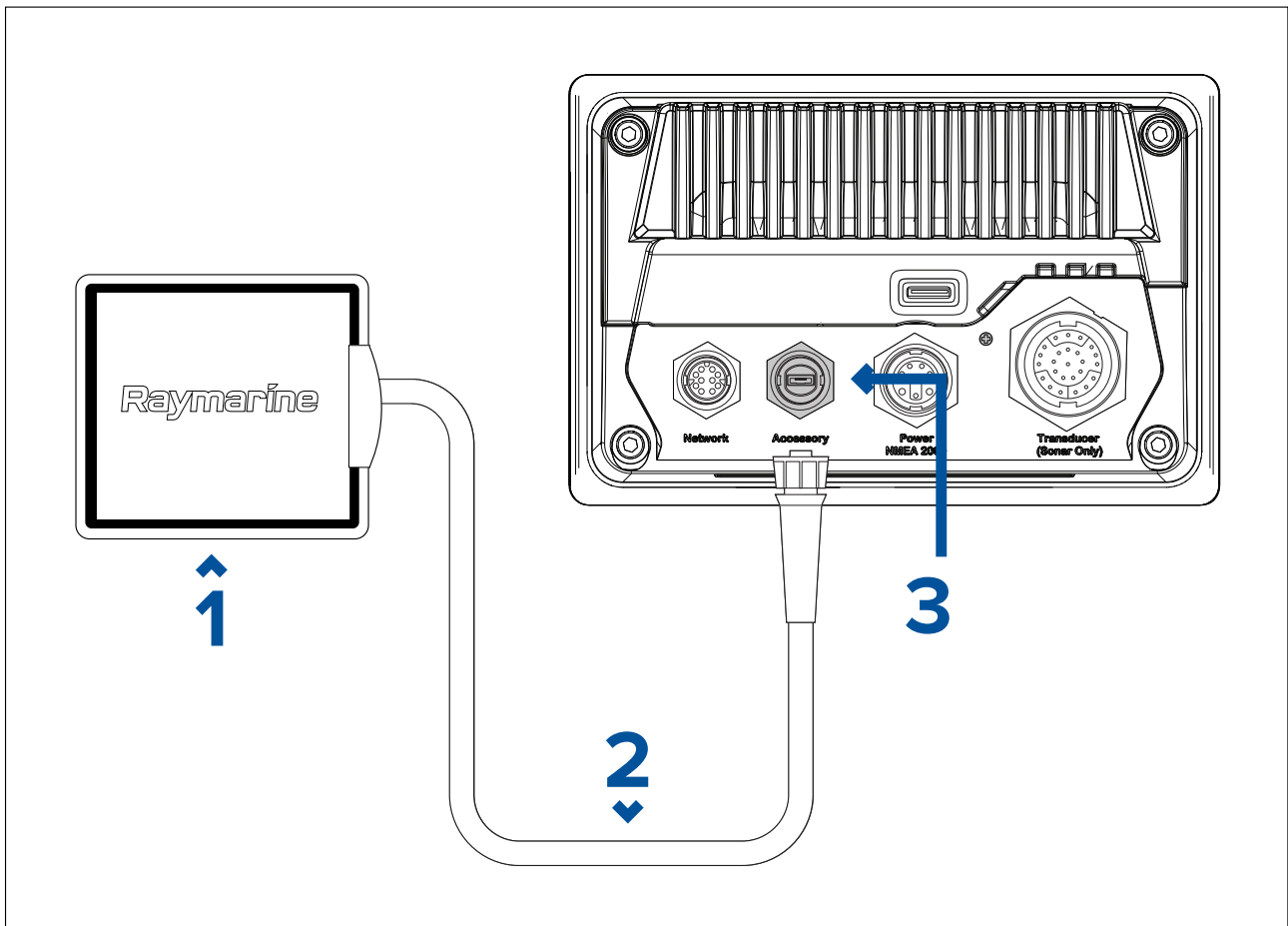

1. RCR-1 microSD card reader
2. 1 m (3.28 ft) captive cable with Micro USB connector
3. MFD accessory port (Micro USB)

### Using the RCR-1 with cartography

Important considerations when using the RCR-1 to read electronic chart cards.

Due to the high data bandwidth requirements of electronic charts (especially when sharing with other networked MFDs), Raymarine recommends that an MFD internal card reader is used for cartography whenever possible.

If the RCR-1 is used for cartography, you must first fit suppression ferrites; for more information refer to: [p.25 – Fitting suppression ferrites](#)

## Network connection to multiple MFDs

The RCR-1 can read electronic chart data from a MicroSD card. The cartography can be shared to multiple MFDs connected on the same network.

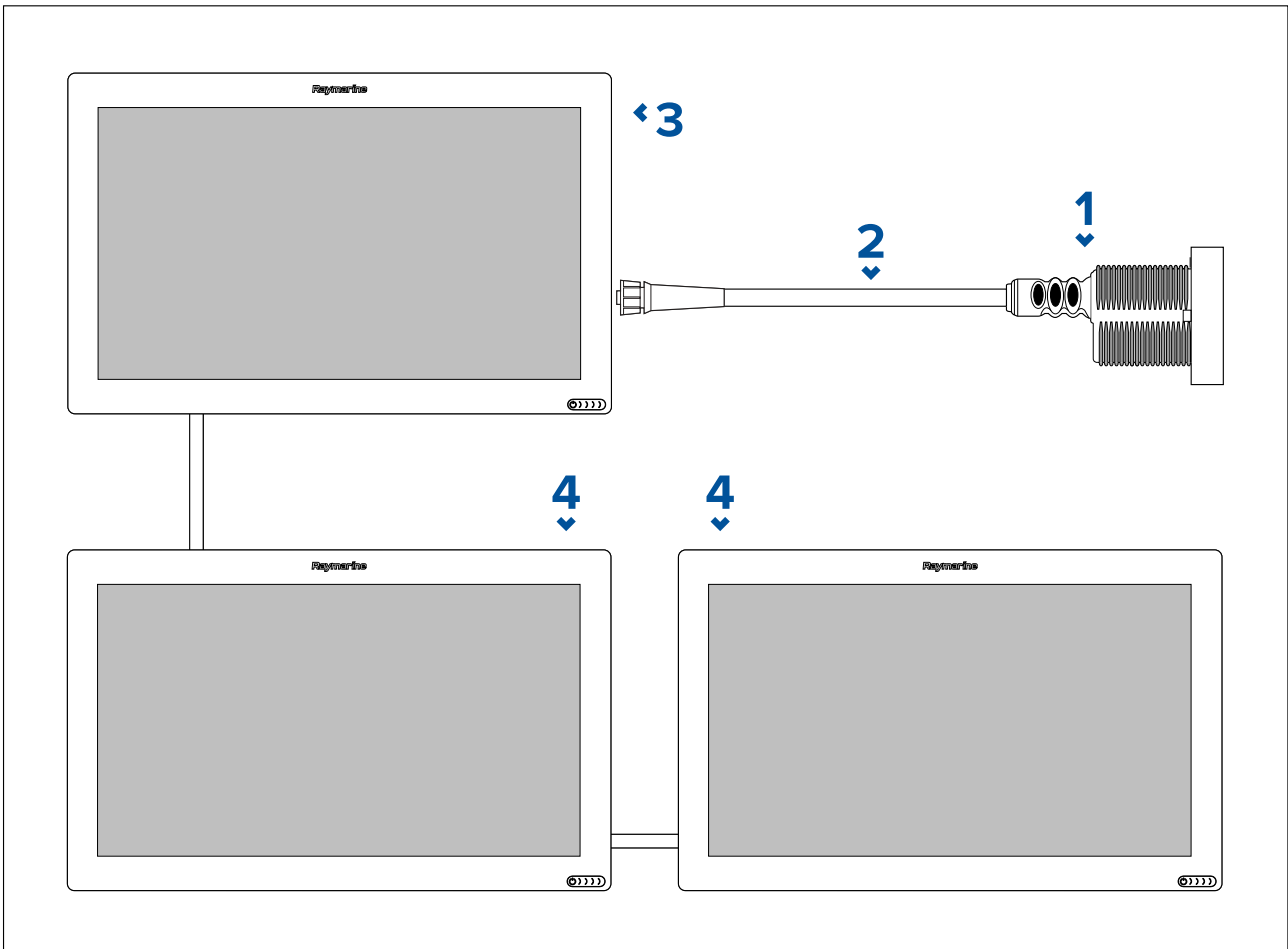

1. RCR-1
2. 1 m (3.28 ft) captive cable (Micro USB)
3. Axiom XL MFD providing power over Micro USB
4. Networked Axiom XL MFDs



## Chapter 8: Operation

### Chapter contents

- 8.1 Compatible MicroSD cards on page 30
- 8.2 Care of MicroSD cards on page 30
- 8.3 Removing MicroSD card from its adaptor on page 30
- 8.4 Inserting MicroSD card into reader on page 31
- 8.5 Removing MicroSD card from reader on page 31
- 8.6 Using the RCR-1 with cartography on page 31

## 8.1 Compatible MicroSD cards

Type	Size	Native card format	MFD supported Format
MicroSDSC (Micro Secure Digital Standard Capacity)	Up to 4GB	FAT12, FAT16 or FAT16B	NTFS, FAT32
MicroSDHC (Micro Secure Digital High Capacity)	4GB to 32GB	FAT32	NTFS, FAT32
MicroSDXC (Micro Secure Digital eXtended Capacity)	32GB to 2TB	exFAT	NTFS, FAT32

**Note:**

- **Speed class rating** — For best performance it is recommended that you use Class 10 or UHS (Ultra High Speed) class memory cards, or better.
- **Use branded memory cards** — When archiving data it is recommended that you use good quality branded cards.

## 8.2 Care of MicroSD cards

Prevent damage and/or data loss.

To avoid irreparable damage to and / or loss of data from MicroSD cards:

- Ensure that cards are fitted the correct way around. DO NOT try to force a card into position.
- DO NOT use a metallic instrument such as a screwdriver or pliers to insert or remove a card.

## 8.3 Removing MicroSD card from its adaptor

MicroSD memory cards are usually supplied already inserted into an SD card adaptor. Remove from the adaptor before use.

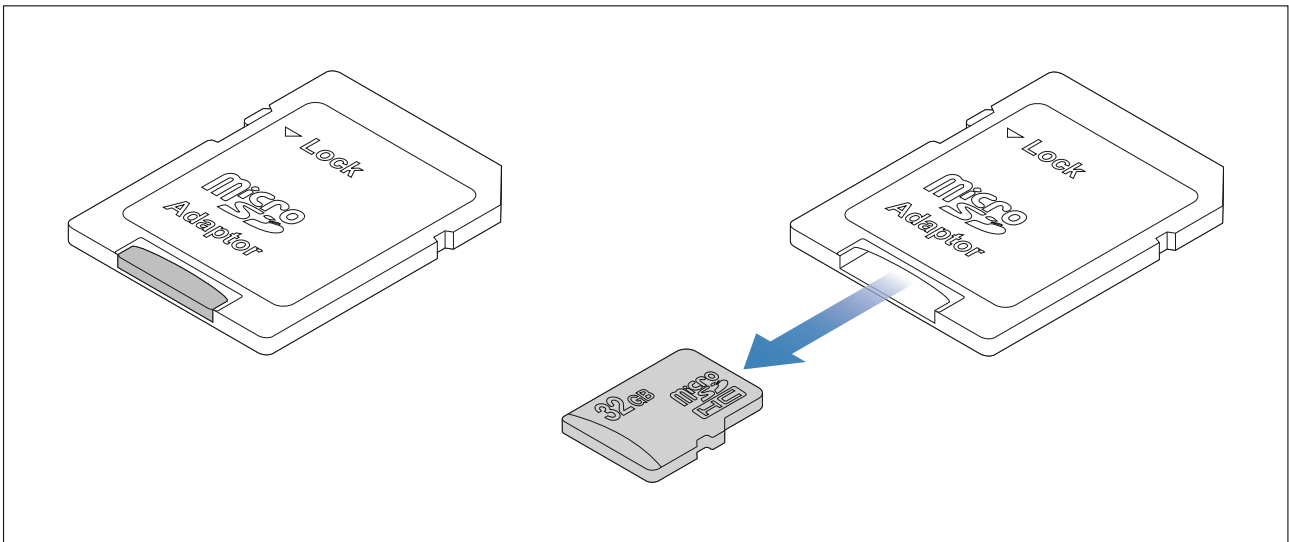

## 8.4 Inserting MicroSD card into reader

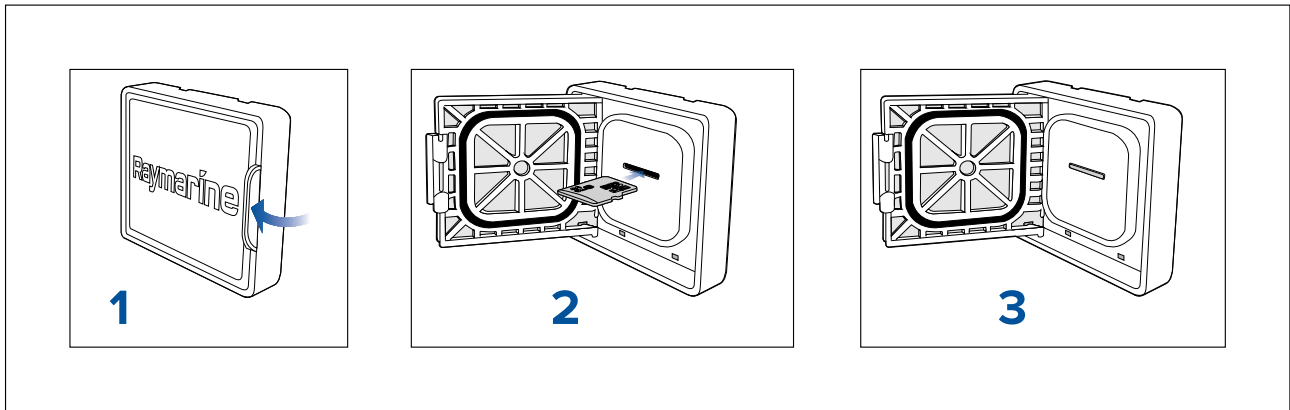

1. Press the tab in and pull the lid open to expose the card slot.
2. With the MicroSD card's connectors facing down, carefully insert the card into the card reader.
3. Push the MicroSD card into the reader until it clicks into place. DO NOT use a metallic instrument such as a screwdriver or pliers to insert or remove a card.

### Important:

- Keep the product's lid closed when not in use.
- DO NOT open the product's lid when it is at risk of getting wet.

## 8.5 Removing MicroSD card from reader

1. With the cover lid open, push the MicroSD card in until it clicks.
2. Pull the MicroSD card free from the card reader.

## 8.6 Using the RCR-1 with cartography

Important considerations when using the RCR-1 to read electronic chart cards.

Due to the high data bandwidth requirements of electronic charts (especially when sharing with other networked MFDs), Raymarine recommends that an MFD internal card reader is used for cartography whenever possible.

If the RCR-1 is used for cartography, you must first fit suppression ferrites; for more information refer to: [p.25 – Fitting suppression ferrites](#)



## Chapter 9: Maintenance

### Chapter contents

- 9.1 Service and maintenance on page 34
- 9.2 Routine equipment checks on page 34

## **9.1 Service and maintenance**

This product contains no user serviceable components. Please refer all maintenance and repair to authorized Raymarine dealers. Unauthorized repair may affect your warranty.

## **9.2 Routine equipment checks**

It is recommended that you perform the following routine checks, on a regular basis, to ensure the correct and reliable operation of your equipment:

- Examine all cables for signs of damage or wear and tear.
- Check that all cables are securely connected.

## Chapter 10: Technical support

### Chapter contents

- 10.1 Raymarine product support and servicing on page 36
- 10.2 Learning resources on page 37

## 10.1 Raymarine product support and servicing

Raymarine provides a comprehensive product support service, as well as warranty, service, and repairs. You can access these services through the Raymarine website, telephone, and e-mail.

### Product information

If you need to request service or support, please have the following information to hand:

- Product name.
- Product identity.
- Serial number.
- Software application version.
- System diagrams.

You can obtain this product information using diagnostic pages of the connected MFD.

### Servicing and warranty

Raymarine offers dedicated service departments for warranty, service, and repairs.

Don't forget to visit the Raymarine website to register your product for extended warranty benefits:

<http://www.raymarine.co.uk/display/?id=788>.

#### **United Kingdom (UK), EMEA, and Asia Pacific:**

- E-Mail: [emea.service@raymarine.com](mailto:emea.service@raymarine.com)
- Tel: +44 (0)1329 246 932

#### **United States (US):**

- E-Mail: [rm-usrepair@flir.com](mailto:rm-usrepair@flir.com)
- Tel: +1 (603) 324 7900

### Web support

Please visit the "Support" area of the Raymarine website for:

- **Manuals and Documents** — <http://www.raymarine.com/manuals>
- **Technical support forum** — <http://forum.raymarine.com>
- **Software updates** — <http://www.raymarine.com/software>

### Worldwide support

#### **United Kingdom (UK), EMEA, and Asia Pacific:**

- Help desk: <https://raymarine.custhelp.com/app/ask>
- Tel: +44 (0)1329 246 777

#### **United States (US):**

- Help desk: <https://raymarine.custhelp.com/app/ask>
- Tel: +1 (603) 324 7900 (Toll-free: +800 539 5539)

#### **Australia and New Zealand (Raymarine subsidiary):**

- E-Mail: [aus.support@raymarine.com](mailto:aus.support@raymarine.com)
- Tel: +61 2 8977 0300

#### **France (Raymarine subsidiary):**

- E-Mail: [support.fr@raymarine.com](mailto:support.fr@raymarine.com)
- Tel: +33 (0)1 46 49 72 30

#### **Germany (Raymarine subsidiary):**

- E-Mail: [support.de@raymarine.com](mailto:support.de@raymarine.com)
- Tel: +49 40 237 808 0

#### **Italy (Raymarine subsidiary):**

- E-Mail: [support.it@raymarine.com](mailto:support.it@raymarine.com)
- Tel: +39 02 9945 1001

#### **Spain (Authorized Raymarine distributor):**

- E-Mail: [sat@azimut.es](mailto:sat@azimut.es)

- Tel: +34 96 2965 102

**Netherlands (Raymarine subsidiary):**

- E-Mail: [support.nl@raymarine.com](mailto:support.nl@raymarine.com)
- Tel: +31 (0)26 3614 905

**Sweden (Raymarine subsidiary):**

- E-Mail: [support.se@raymarine.com](mailto:support.se@raymarine.com)
- Tel: +46 (0)317 633 670

**Finland (Raymarine subsidiary):**

- E-Mail: [support.fi@raymarine.com](mailto:support.fi@raymarine.com)
- Tel: +358 (0)207 619 937

**Norway (Raymarine subsidiary):**

- E-Mail: [support.no@raymarine.com](mailto:support.no@raymarine.com)
- Tel: +47 692 64 600

**Denmark (Raymarine subsidiary):**

- E-Mail: [support.dk@raymarine.com](mailto:support.dk@raymarine.com)
- Tel: +45 437 164 64

**Russia (Authorized Raymarine distributor):**

- E-Mail: [info@mikstmarine.ru](mailto:info@mikstmarine.ru)
- Tel: +7 495 788 0508

## 10.2 Learning resources

Raymarine has produced a range of learning resources to help you get the most out of your products.

### Video tutorials

**Raymarine official channel on YouTube:**

- [YouTube](#)

**LightHouse™ 3 tips and tricks:**

- [Raymarine website](#)

**Video Gallery:**

- [Raymarine website](#)

**Note:**

- Viewing the videos requires a device with an Internet connection.
- Some videos are only available in English.

### Training courses

Raymarine regularly runs a range of in-depth training courses to help you make the most of your products. Visit the Training section of the Raymarine website for more information:

- <http://www.raymarine.co.uk/view/?id=2372>

### Technical support forum

You can use the Technical support forum to ask a technical question about a Raymarine product or to find out how other customers are using their Raymarine equipment. The resource is regularly updated with contributions from Raymarine customers and staff:

- <http://forum.raymarine.com>



# Chapter 11: Technical specification

## Chapter contents

- 11.1 Technical specification on page 40
- 11.2 Compliance on page 40

## 11.1 Technical specification

### Environmental specification

<b>Operating temperature</b>	-25 °C to +55 °C (-13 °F to 131 °F)
<b>Storage temperature</b>	-30 °C to +70 °C (-22 °F to 158 °F)
<b>Relative humidity</b>	Maximum 93%
<b>Waterproof rating</b>	IPx6 & IPx7 (lid closed)

### Power

<b>Power consumption</b>	5 V dc
<b>Current</b>	Peak 0.25 A

### Weight

<b>Weight</b>	200 g
---------------	-------

### Wired connections

<b>USB</b>	1 x Micro USB
------------	---------------

## 11.2 Compliance

The product has been tested to the relevant sections of the standards listed below.

EMC	<ul style="list-style-type: none"><li>• EN 60945:2002</li><li>• EMC Directive 2014/30/EU</li><li>• Australia and New Zealand C-Tick compliance level 2</li></ul>
-----	--





# Index

## C

Cable	
Bend radius.....	24
Protection .....	24
Routing .....	24
Security.....	24
Strain relief.....	24
Compatibility	
MicroSD card .....	30
Compatible MFDs.....	12
Connections .....	26
General cabling guidance.....	24
Connectors, <i>See</i> Connections	
Contact details.....	36

## D

Declaration of Conformity.....	8
--------------------------------	---

## E

Electromagnetic Compatibility.....	7, 18
EMC, <i>See</i> Electromagnetic Compatibility	
Environmental specification .....	40

## F

Flush mounting.....	20
---------------------	----

## I

Installation	
Parts supplied .....	14
Product dimensions .....	16

## L

LightHouse™ 3	
Tips and Tricks.....	37
Location requirements .....	18

## M

Maintenance.....	34
MicroSD	
Adaptor .....	30
MicroSD card.....	30
Mounting	
Flush mounting .....	20
Surface mounting.....	21

## P

Parts supplied.....	14
Product dimensions.....	16
Product documentation .....	12
Product overview.....	12
Product recycling (WEEE) .....	8
Product support.....	36

## R

Routine checks.....	34
---------------------	----

## S

Service Center.....	36
Servicing.....	34
Support forum .....	37
Suppression ferrites .....	25
Surface mounting .....	21

## T

Technical specification .....	39–40
Technical support.....	36–37
Temperature range .....	40
Training courses.....	37

## V

Video Gallery.....	37
--------------------	----

## W

Warranty .....	36
Water ingress .....	40
WEEE Directive.....	8







**Raymarine**

Marine House, Cartwright Drive, Fareham, Hampshire.  
PO15 5RJ. United Kingdom.

Tel: +44 (0)1329 246 700

[www.raymarine.com](http://www.raymarine.com)

**Raymarine®**

a brand by  **FLIR®**